

Operating manual  
**LV-servoTEC S2 1xx**

Version R1d

Edition: May 2015

Article No.: 1076776

**IEF-Werner GmbH**  
**Wendelhofstr. 6**  
**78120 Furtwangen**  
**Phone: 0049-7723/925-0**  
**Fax:0049-7723/925-100**  
**[www.IEF-Werner.de](http://www.IEF-Werner.de)**

**Modification history:**

Document code	Date	Modification
..._1076776_LVservoTECS2_1xx_R1a.doc	January 2008	Creation of this document
MAN_EN_1076776_LV-servoTEC_S2_1xx_R1b.doc	2011-11-13	File name slightly modified and new logo embedded
MAN_EN_1076776_LV-servoTEC_S2_1xx_R1c.doc	2013-01-29	Update of the error messages (see section <i>Error messages, page 98 onwards</i> )
MAN_EN_1076776_LV-servoTEC_S2_1xx_R1c.doc	2015-05-21	Exchanging graphic 4-pin to 2-pin for connection of CAN bus cabling (see <i>chapter 7.14.5, page 88</i> )

Trademarks and trade names are used without an assurance of their free usability. Although the texts and examples were created with great thoroughness, errors cannot be fully excluded. IEF-Werner GmbH does not assume legal responsibility nor any liability for missing or incorrect statements and their consequences.

IEF-Werner GmbH reserves the right to modify or improve without previous notice the software or hardware or parts of it as well as the supplied documentation or parts of it.

IEF-Werner GmbH expressly reserves all rights for duplication and photomechanical reproduction, including extracts.

We are always grateful for suggestions for improvements and information about errors.

© May 2015, IEF-Werner GmbH

## Table of Contents

<b>1</b>	<b>General</b>	<b>11</b>
1.1	Documentation	11
1.2	Scope of supply	12
	LV-servoTEC S2 1xx	12
	Connector set: POWER connector	12
<b>2</b>	<b>Safety notes for electrical drives and controllers</b>	<b>13</b>
2.1	Used symbols	13
2.2	General notes	14
2.3	Danger resulting from misuse	15
2.4	Safety notes	16
2.4.1	General safety notes	16
2.4.2	Safety notes for assembly and maintenance	17
2.4.3	Protection against contact with electrical parts	18
2.4.4	Protection against electrical shock by means of protective extra-low voltage (PELV)	19
2.4.5	Protection against dangerous movements	19
2.4.6	Protection against contact with hot parts	20
2.4.7	Protection during handling and assembly	20
2.4.8	The following general safety notes apply:	21
<b>3</b>	<b>Product description</b>	<b>22</b>
3.1	General	22
3.2	Power supply	24
3.2.1	Single-phase AC supply with active PFC	24
3.2.2	DC bus coupling, DC supply	25
3.2.3	Mains fuse	26
3.3	Brake chopper	26
3.4	Communication interfaces	26
3.4.1	RS232 interface	26
3.4.2	CAN-Bus	26
3.4.3	Profibus	27
3.4.4	I/O functions and device controller	27
<b>4</b>	<b>Technical data</b>	<b>28</b>
4.1	Operating and display elements	29
4.2	Supply [X9]	29
4.3	Motor connection [X6]	31
4.4	Motor feedback connection [X2A] and [X2B]	31
4.4.1	Resolver connection [X2A]	31

4.4.2	Encoder connection [X2B]	32
4.5	Communication interfaces	34
4.5.1	RS232 [X5]	34
4.5.2	CAN bus [X4]	34
4.5.3	I/O interface [X1]	34
4.5.4	Incremental encoder input [X10] <FW3.x>	35
4.5.5	Incremental encoder output [X11] <FW2.0>	35
<b>5</b>	<b>Function overview</b>	<b>37</b>
5.1	Motors	37
5.1.1	Synchronous servo motors	37
5.1.2	Linear motors <FW3.x>	37
5.2	Functions of the servo positioning controller LV-servoTEC S2 1xx	37
5.2.1	Compatibility	37
5.2.2	Pulse width modulation (PWM)	38
5.2.3	Setpoint management	38
5.2.4	Torque-controlled mode	39
5.2.5	Speed-controlled mode	39
5.2.6	Torque-limited speed control	39
5.2.7	Synchronization to the external clock signal	39
5.2.8	Load torque compensation for vertical axes	39
5.2.9	Positioning and position control	40
5.2.10	Synchronisation, electrical transmissions <FW3.x>	40
5.2.11	Brake management	40
5.3	Positioning control	41
5.3.1	Overview	41
5.3.2	Relative positioning	42
5.3.3	Driving profile generator	42
5.3.4	Homing	43
5.3.5	Positioning sequences	43
5.3.6	Optional stop input	44
5.3.7	Contouring control with linear interpolation	44
5.3.8	Time-synchronized multi-axis positioning	45
<b>6</b>	<b>Functional safety technology</b>	<b>46</b>
6.1	General, intended use	46
Stop category 0		48
6.2	Integrated "safe stop" function	48
6.2.1	General / description of "safe stop" function	48
6.2.2	Safe holding brake activation	50
6.2.3	Mode of operation / timing	51
6.2.4	Application examples	54
6.2.4.1	Emergency stop circuit:	54

<b>7</b>	<b>Mechanical installation</b>	<b>58</b>
7.1	Important notes	58
7.2	View of the device	60
7.3	Mounting	62
7.4	Connector configuration	64
7.5	LV-servoTEC S2 1xx complete system	65
7.6	Connection: Power supply [X9]	67
7.6.1	Device side [X9]	67
7.6.2	Counterplug [X9]	67
7.6.3	Pin configuration [X9]	67
7.6.4	Cable type and design [X9]	67
7.6.5	Connection notes [X9]	68
7.7	Connection: Motor [X6]	69
7.7.1	Device side [X6]	69
7.7.2	Counterplug [X6]	69
7.7.3	Pin configuration [X6]	69
7.7.4	Cable type and design [X6]	69
7.7.5	Connection notes [X6]	70
7.8	Connection: I/O communication [X1]	71
7.8.1	Device side [X1]	73
7.8.2	Counterplug [X1]	73
7.8.3	Pin configuration [X1]	74
7.8.4	Cable type and design [X1]	75
7.8.5	Connection notes [X1]	75
7.9	Connection: Safe Standstill [X3]	76
7.9.1	Device side [X3]	76
7.9.2	Counterplug [X3]	76
7.9.3	Pin assignment [X3]	76
7.9.4	Connection notes [X3]	76
7.10	Connection: Resolver [X2A]	77
7.10.1	Device side [X2A]	77
7.10.2	Counterplug [X2A]	77
7.10.3	Pin configuration [X2A]	77
7.10.4	Cable type and design [X2A]	77
7.10.5	Connection notes [X2A]	78
7.11	Connection: Encoder [X2B]	79
7.11.1	Device side [X2B]	79
7.11.2	Counterplug [X2B]	79
7.11.3	Pin configuration [X2B]	79
7.11.4	Cable type and design [X2B]	81
7.11.5	Connection notes [X2B]	82

---

7.12	Connection: Incremental encoder input [X10]	84
7.12.1	Device side [X10]	84
7.12.2	Counterplug [X10]	84
7.12.3	Pin configuration [X10]	84
7.12.4	Cable type and design [X10]	84
7.12.5	Connection notes [X10]	84
7.13	Connection: Incremental encoder output [X11]	85
7.13.1	Device side [X11]	85
7.13.2	Counterplug [X11]	85
7.13.3	Pin configuration [X11]	85
7.13.4	Cable type and design [X11]	86
7.13.5	Connection notes [X11]	86
7.14	Connection: CAN-Bus [X4]	87
7.14.1	Device side [X4]	87
7.14.2	Counterplug [X4]	87
7.14.3	Pin configuration [X4]	87
7.14.4	Cable type and design [X4]	87
7.14.5	Connection notes [X4]	88
7.15	Connection: RS232/COM [X5]	89
7.15.1	Device side [X5]	89
7.15.2	Counterplug [X5]	89
7.15.3	Pin configuration [X5]	89
7.15.4	Cable type and design [X5]	89
7.15.5	Connection notes [X5]	89
7.16	Notes on safe and EMC-compliant installation	90
7.16.1	Definition and terms	90
7.16.2	General information on EMC	90
7.16.3	EMC areas: first and second environment	91
7.16.4	EMC-compliant cabling	91
7.16.5	Operation with long motor cables	92
7.16.6	ESD protection	92
<b>8</b>	<b>Initial operation</b>	<b>93</b>
8.1	General notes on connection	93
8.2	Tools / material	93
8.3	Connecting the motor	93
8.4	Connecting the servo positioning controller LV-servoTEC S2 1xx to the power supply	93
8.5	Connecting the PC	94
8.6	Checking operability	94
<b>9</b>	<b>Service functions and error messages</b>	<b>95</b>
9.1	Protection and service functions	95
9.1.1	Overview	95

---

9.1.2	Overcurrent and short-circuit monitoring	95
9.1.3	Overvoltage monitoring for the DC bus	95
9.1.4	Temperature monitoring of the heat sink	95
9.1.5	Monitoring of the motor	96
9.1.6	I <sup>2</sup> t monitoring	96
9.1.7	Power monitoring for the brake chopper	96
9.1.8	I <sup>2</sup> t monitoring for the PFC stage	96
9.1.9	Initial operation status	96
9.1.10	Operating hours meter	96
9.2	Display of operating mode and error messages	97
9.2.1	Operating mode and error display	97
9.2.2	Error messages	98
<b>10</b>	<b>Technologiemodule</b>	<b>115</b>
10.1	SERCOS module	115
10.1.1	Product description	115
10.1.2	Technical data	115
10.1.3	Optical waveguide specification	116
10.2	EA88 interface technology module	117
10.2.1	Product description	117
10.2.2	Technical data	117
10.2.2.1	General data	117
10.2.2.2	Digital inputs	118
10.2.2.3	Digital outputs	118
10.2.3	Pin assignment and cable specifications	119
10.2.3.1	Power supply	119
10.2.3.2	Pin assignments	119
10.2.4	Mating connector	120
10.2.5	Connection notes	120
10.3	General installation notes for technology modules	121

## Table of Figures

Figure 1: Type key	22
Figure 2: Schematic setup of PFC stage	25
Figure 3: Performance curve of the PFC stage	30
Figure 4: Control scheme of the LV-servoTEC S2 1xx	37
Figure 5: Driving profiles of servo positioning controller LV-servoTEC S2 1xx	42
Figure 6: Path program	43
Figure 7: Linear interpolation between two data values	44
Figure 8: Block diagram “safe stop” as per EN 954-1 category 3	49
Figure 9: Timing of “safe stop” as per EN 954-1 category 3	51
Figure 10: Emergency-off circuit in accordance with 945-1, category 3, and stop category 0 in accordance with 60204-1.	54
Figure 11: Safety door monitoring in accordance with 945-1, category 3, and stop category 0 in accordance with 60204-1.	56
Figure 12: Servo positioning controller LV-servoTEC S2 1 XX: Installation space	59
Figure 13: Servo positioning controller LV-servoTEC S2 1 02: Front view	60
Figure 14: Servo positioning controller LV-servoTEC S2 1 02: Top view	61
Figure 15: Servo positioning controller LV-servoTEC S2 102: Bottom view	62
Figure 16: Servo positioning controller LV-servoTEC S2 1xx: Mounting plateElectrical installation	63
Figure 17: Connection to power supply and motor	64
Figure 18: Complete setup of the LV-servoTEC S2 1xx with motor and PC	66
Figure 19: Supply [X9]	68
Figure 20: Motor connection [X6]	70
Figure 21: Connecting a holding brake with high current draw (> 1A) to the device	70
Figure 22: Basic circuit diagram connector [X1]	72
Figure 23: Connection notes [X3]: without safety function	76
Figure 24: Pin configuration: Resolver connection [X2A]	78
Figure 25: Pin configuration: Analog incremental encoder – optional [X2B]	82
Figure 26: Pin configuration: Incremental encoder with serial communication interface (e.g. EnDat, HIPERFACE) – optional [X2B]	82
Figure 27: Pin configuration: Digital incremental encoder – option [X2B]	83
Figure 28: Pin configuration: Input of the incremental encoder [X10]	85
Figure 29: Pin configuration: Incremental encoder output [X11]	86
Figure 30: Cabling example for CAN-Bus	88
Figure 31: Pin configuration RS232 null modem cable [X5]	89
Figure 32: SERCOS module: Front view	116
Figure 33: Position of the pin-and-socket connectors [X21] and [X22] at the front plate	120

## Table of Tables

Table 1: Scope of supply	12
Table 2: Connector set: DSUB and POWER connector	12
Table 3: Technical data: Ambient conditions and qualification	28
Table 4: Technical specifications: Dimensions and weight	28
Table 5: Technical specifications: Cable specifications	28
Table 6: Technical specifications: Motor temperature monitoring	29
Table 7: Display elements and RESET button	29
Table 8: Technical specifications: Performance data [X9]	29
Table 9: Technical specifications: Internal brake resistor [X9]	29
Table 10: Technical specifications: External brake resistor [X9]	30
Table 11: Performance data of PFC stage	30
Table 12: Technical specifications: Motor connection specifications [X6]	31
Table 13: Technical specifications: Resolver [X2A]	32
Table 14: Technical specifications: Resolver interface [X2A]	32
Table 15: Technical specifications: Encoder evaluation [X2B]	33
Table 16: Technical specifications: RS232 [X5]	34
Table 17: Technical specifications: CAN bus [X4]	34
Table 18: Technical specifications: Digital inputs and outputs [X1]	34
Table 19: Technical specifications: analog inputs and outputs [X1]	35
Table 20: Technical specifications: Incremental encoder input [X10]	35
Table 21: Technical specifications: Incremental encoder output [X11]	36
Table 22: Output voltage at the motor terminals at $U_{ZK} = 360V$	38
Table 23: Description of the requirements to be met for the categories in accordance with EN 954-1	46
Table 24: EMERGENCY OFF and EMERGENCY STOP as per EN 60204-1	47
Table 25: Stop categories	48
Table 26: Pin configuration [X9]	67
Table 27: Connector [X9]: External brake resistor	68
Table 28: Pin configuration [X6]	69
Table 29: Connector configuration: I/O communication [X1]	74
Table 30: Pin assignment [X3]	76
Table 31: Pin configuration [X2A]	77
Table 32: Pin configuration: Analog incremental encoder – optional [X2B]	79
Table 33: Pin configuration: Incremental encoder with serial communication interface (e.g. EnDat, HIPERFACE) – optional [X2B]	80
Table 34: Pin configuration: Digital incremental encoder – option [X2B]	81
Table 35: Pin configuration [X10]: Incremental encoder input	84
Table 36: Pin configuration [X11]: Incremental encoder output	85
Table 37: Pin configuration CAN-Bus [X4]	87
Table 38: Pin configuration RS232 interface [X5]	89
Table 39: EMC requirements: First and second environment	91

Table 40: Operating mode and error display	97
Table 41: Error messages	98
Table 42: Technical data: SERCOS module: Ambient conditions, dimensions and weight	115
Table 43: Technical data: EA88 interface	117
Table 44: Digital inputs [X21]: EA88 interface	118
Table 45: Digital outputs [X22]: EA88 interface	118
Table 46: EA88: Connector [X21] for 8 digital inputs	119
Table 47: EA88: Connector [X22] for 8 digital outputs	119

# 1 General

## 1.1 Documentation

This product manual serves the purpose of a safe use of the LV-servoTEC S2 1xx series servo positioning controller. It contains safety notes, which must be complied with.

Further information can be found in the following manuals of the LV-servoTEC S2 product range:

- Software manual "Servo Positioning Controller LV-servoTEC S2": Description of the device functionality and the software functions of the firmware including the RS232 communication. Description of the S2Commander™ parameterisation program with instructions concerning the start-up of LV-servoTEC S2 servo positioning controllers.
- Product Manual "Servo Positioning Controller LV-servoTEC S2 1xx": Description of the technical specifications and the device functionality as well as notes on the installation and the operation of the servo positioning controller LV-servoTEC S2 1xx.
- Product manual "Servo Positioning Controller LV-servoTEC S2 ": Description of the technical data and the device functionality plus notes concerning the installation and operation of LV-servoTEC S2 3 02, 3 05 and 3 10 servo positioning controllers.
- PROFIBUS Manual "Servo Positioning Controller LV-servoTEC S2": Description of the implemented PROFIBUS-DP protocol.

The entire software functionality of the new LV-servoTEC S2 product range will be implemented in the course of a step-by-step development process.

This version of the hardware manual contains functions of firmware version 3.2 and of firmware version 3.x, which is currently being prepared.

Whenever relevant, special notes like <FW3.x> are included in chapter headings and in the text block, indicating that the functions of firmware version 3.x are available.

## 1.2 Scope of supply

The scope of supply includes:

Table 1: Scope of supply

LV-servoTEC S2 1xx			
1x	Scope:	1x	Counterplug PHOENIX Mini-Combicon MC 1,5/ 6-GF-3,81 with isolated cable bridge

Counterplugs for power, controller and shaft encoder connections are not included in the standard scope of supply. They can, however, be ordered as accessories.

Table 2: Connector set: DSUB and POWER connector

1x	<b>Connector set: DSUB connector</b>			IEF-order no.: 1075282
	Content:	3x	9-pole DSUB connector, male	
		1x	9-pole DSUB connector, female	
		4x	DSUB housing for 9-pole DSUB connector	
		1x	15-pole DSUB connector, male	
		1x	DSUB housing for 15-pole DSUB connector	
		1x	25-pole DSUB connector, male	
1x		DSUB housing for 25-pole DSUB connector		
1x	<b>Connector set: POWER connector</b>			
	Content:	2x	9-pole PHOENIX Mini-Combicon connector MC 1.5/9-ST-5.08	
		1x	Numbers 1-10	
2x		PHOENIX Mini-Combicon connector housing KGG-MC 1.5/12		

## 2 Safety notes for electrical drives and controllers

### 2.1 Used symbols



Information

Important information and notes.



Caution!

Nonobservance may result in severe property damages.



**DANGER!**

Nonobservance may result in property damages and in personal injuries.



**Caution! Dangerous voltages.**

The safety note indicates a possible perilous voltage.

## 2.2 General notes

In the case of damage resulting from non-compliance of the safety notes in this manual IEF-Werner GmbH will assume any liability.



Prior to the initial use you must read the chapters Safety notes for electrical drives and controllers starting on page 13 and 7.16 Notes on safe and EMC-compliant installation page 90.

If the documentation in the language at hand is not understood accurately, please contact and inform your supplier.

Sound and safe operation of the servo drive controller requires proper and professional transportation, storage, assembly and installation as well as proper operation and maintenance. Only trained and qualified personnel may handle electrical devices:

### TRAINED AND QUALIFIED PERSONNEL

in the sense of this product manual or the safety notes on the product itself are persons who are sufficiently familiar with the project, the setup, assembly, commissioning and operation of the product as well as all warnings and precautions as per the instructions in this manual and who are sufficiently qualified in their field of expertise:

- Education and instruction concerning the standards and accident prevention regulations for the application, or authorisation to switch devices/systems on and off and to ground them as per the standards of safety engineering and to efficiently label them as per the job demands.
- Education and instruction as per the standards of safety engineering regarding the maintenance and use of adequate safety equipment.
- First aid training.

The following notes must be read prior to the initial operation of the system to prevent personal injuries and/or property damages:



These safety notes must be complied with at all times.



Do not try to install or commission the servo drive controller before carefully reading all safety notes for electrical drives and controllers contained in this document. These safety instructions and all other user notes must be read prior to any work with the servo drive controller.



In case you do not have any user notes for the servo drive controller, please contact your sales representative. Immediately demand these documents to be sent to the person responsible for the safe operation of the servo drive controller.



If you sell, rent and/or otherwise make this device available to others, these safety notes must also be included.



The user must not open the servo drive controller for safety and warranty reasons.



Professional control process design is a prerequisite for sound functioning of the servo drive controller!

**DANGER!**

Inappropriate handling of the servo drive controller and non-compliance of the warnings as well as inappropriate intervention in the safety features may result in property damage, personal injuries, electric shock or in extreme cases even death.

## 2.3 Danger resulting from misuse

**DANGER!**

High electrical voltages and high load currents!

Danger to life or serious personal injury from electrical shock!

**DANGER!**

High electrical voltage caused by wrong connections!

Danger to life or serious personal injury from electrical shock!

**DANGER!**

Surfaces of device housing may be hot!

Risk of injury! Risk of burning!

**DANGER!**

**Dangerous movements!**

Danger to life, serious personal injury or property damage due to unintentional movements of the motors!

## 2.4 Safety notes

### 2.4.1 General safety notes



The servo drive controller corresponds to IP20 class of protection as well as pollution level 1. Make sure that the environment corresponds to this class of protection and pollution level.



Only use replacements parts and accessories approved by the manufacturer.



The devices must be connected to the mains supply as per EN regulations, so that they can be cut off the mains supply by means of corresponding separation devices (e.g. main switch, contactor, power switch).



The servo drive controller may be protected using an AC/DC sensitive 300mA fault current protection switch (RCD = Residual Current protective Device).



Gold contacts or contacts with a high contact pressure should be used to switch the control contacts.



Preventive interference rejection measures should be taken for control panels, such as connecting contactors and relays using RC elements or diodes.



The safety rules and regulations of the country in which the device will be operated must be complied with.



The environment conditions defined in the product documentation must be kept. Safety-critical applications are not allowed, unless specifically approved by the manufacturer.



For notes on installation corresponding to EMC, please refer to *chapter 7.16 Notes on safe and EMC-compliant installation (page 90)*. The compliance with the limits required by national regulations is the responsibility of the manufacturer of the machine or system.



The technical data and the connection and installation conditions for the servo drive controller are to be found in this product manual and must be met.



#### **DANGER!**

The general setup and safety regulations for work on power installations (e.g. DIN, VDE, EN, IEC or other national and international regulations) must be complied with.

Non-compliance may result in death, personal injury or serious property damages.



Without claiming completeness, the following regulations and others or standards apply:

VDE 0100	Regulations for the installation of high voltage (up to 1000 V) devices
EN 60204-1	Electrical equipment of machines
EN 50178	Electronic equipment for use in power installations
EN ISO 12100	Safety of machinery – Basic terminology, general principles for design
EN 1050	Safety of machinery – Principles for risk assessment
EN 1037	Safety of machinery – Prevention of unexpected start-up
EN 954-1	Safety-related parts of control systems

#### 2.4.2 Safety notes for assembly and maintenance

The appropriate DIN, VDE, EN and IEC regulations as well as all national and local safety regulations and rules for the prevention of accidents apply for the assembly and maintenance of the system. The plant engineer or the operator is responsible for compliance with these regulations:



The servo drive controller must only be operated, maintained and/or repaired by personnel trained and qualified for working on or with electrical devices.

Prevention of accidents, injuries and/or damages:



Additionally secure vertical axes against falling down or lowering after the motor has been switched off, e.g. by means of:

- Mechanical locking of the vertical axle,
- External braking, catching or clamping devices or
- Sufficient balancing of the axle.



The motor holding brake supplied by default or an external motor holding brake driven by the drive controller alone is not suitable for personal protection!



Render the electrical equipment voltage-free using the main switch and protect it from being switched on again until the DC bus circuit is discharged, in the case of:

- Maintenance and repair work
- Cleaning
- long machine shutdowns



Prior to carrying out maintenance work make sure that the power supply has been turned off, locked and the DC bus circuit is discharged.



The external or internal brake resistor carries dangerous DC bus voltages during operation of the servo drive controller and up to 5 minutes thereafter. Contact may result in death or serious personal injury.



Be careful during the assembly. During the assembly and also later during operation of the drive, make sure to prevent drill chips, metal dust or assembly parts (screws, nuts, cable sections) from falling into the device.



Also make sure that the external power supply of the controller (24V) is switched off.



The DC bus circuit or the mains supply must always be switched off prior to switching off the 24V controller supply.



Carry out work in the machine area only, if AC and/or DC supplies are switched off. Switched off output stages or controller enablings are no suitable means of locking. In the case of a malfunction the drive may accidentally be put into action.

This does not apply to drives with the special "safe stop" features in accordance with EN954-1 CAT 3



Initial operation must be carried out with idle motors, to prevent mechanical damages e.g. due to the wrong direction of rotation.



Electronic devices are never fail-safe. It is the user's responsibility, in the case an electrical device fails, to make sure the system is transferred into a secure state.



The servo drive controller and in particular the brake resistor, externally or internally, can assume high temperatures, which may cause serious burns.

### 2.4.3 Protection against contact with electrical parts

This section only concerns devices and drive components carrying voltages exceeding 50 V. Contact with parts carrying voltages of more than 50 V can be dangerous for people and may cause electrical shock. During operation of electrical devices some parts of these devices will inevitably carry dangerous voltages.



**DANGER!**

High electrical voltage!

Danger to life, danger due to electrical shock or serious personal injury!

The appropriate DIN, VDE, EN and IEC regulations as well as all national and local safety regulations and rules for the prevention of accidents apply for the assembly and maintenance of the system. The plant engineer or the operator is responsible for compliance with these regulations:



Before switching on the device, install the appropriate covers and protections against accidental contact. Rack-mounted devices must be protected against accidental contact by means of a housing, e.g. a switch cabinet. The regulations VGB4 must be complied with!



Always connect the ground conductor of the electrical equipment and devices securely to the mains supply. Due to the integrated line filter the leakage current exceeds 3.5 mA!



Comply with the minimum copper cross-section for the ground conductor over its entire length as per EN60617!



Prior to the initial operation, even for short measuring or testing purposes, always connect the ground conductor of all electrical devices as per the terminal diagram or connect it to the ground wire. Otherwise the housing may carry high voltages which can cause electrical shock.



Do not touch electrical connections of the components when switched on.



Prior to accessing electrical parts carrying voltages exceeding 50 Volts, disconnect the device from the mains or power supply. Protect it from being switched on again.



For the installation the amount of DC bus voltage must be considered, particularly regarding insulation and protective measures. Ensure proper grounding, wire dimensioning and corresponding short-circuit protection.



The device comprises a rapid discharge circuit for the DC bus as per EN60204 section 6.2.4. In certain device constellations, however, mostly in the case of parallel connection of several servo drive controllers in the DC bus or in the case of an unconnected brake resistor, this rapid discharge may be rendered ineffective. The servo drive controllers can carry voltage until up to 5 minutes after being switched off (residual capacitor charge).

#### 2.4.4 Protection against electrical shock by means of protective extra-low voltage (PELV)

All connections and terminals with voltages between 5 and 50 Volts at the servo drive controller are protective extra-low voltage, which are designed safe from contact in correspondence with the following standards:

International: IEC 60364-4-41

European countries within the EU: EN 50178/1998, section 5.2.8.1.



#### **DANGER!**

High electrical voltages due to wrong connections!

Danger to life, risk of injury due to electrical shock!

Only devices and electrical components and wires with a protective extra low voltage (PELV) may be connected to connectors and terminals with voltages between 0 to 50 Volts.

Only connect voltages and circuits with protection against dangerous voltages. Such protection may be achieved by means of isolation transformers, safe optocouplers or battery operation.

#### 2.4.5 Protection against dangerous movements

Dangerous movements can be caused by faulty control of connected motors, for different reasons:

- Improper or faulty wiring or cabling
- Error in handling of components
- Error in sensor or transducer
- Defective or non-EMC-compliant components
- Error in software in superordinated control system

These errors can occur directly after switching on the device or after an indeterminate time of operation.

The monitors in the drive components for the most part rule out malfunctions in the connected drives. In view of personal protection, particularly the danger of personal injury and/or property damage, this may not be relied on exclusively. Until the built-in monitors come into effect, faulty drive movements must be taken into account; their magnitude depends on the type of control and on the operating state.



**DANGER!**

Dangerous movements!

Danger to life, risk of injury, serious personal injuries or property damage!

For the reasons mentioned above, personal protection must be ensured by means of monitoring or superordinated measures on the device. These are installed in accordance with the specific data of the system and a danger and error analysis by the manufacturer. The safety regulations applying to the system are also taken into consideration. Random movements or other malfunctions may be caused by switching the safety installations off, by bypassing them or by not activating them.

#### 2.4.6 Protection against contact with hot parts



**DANGER!**

Housing surfaces may be hot!

Risk of injury! Risk of burning!



Do not touch housing surfaces in the vicinity of heat sources! Danger of burning!



Before accessing devices let them cool down for 10 minutes after switching them off.



Touching hot parts of the equipment such as the housing, which contain heat sinks and resistors, may cause burns!

#### 2.4.7 Protection during handling and assembly

Handling and assembly of certain parts and components in an unsuitable manner may under adverse conditions cause injuries.



**DANGER!**

Risk of injury due to improper handling!

Personal injury due to pinching, shearing, cutting, crushing!

#### 2.4.8 The following general safety notes apply:



Comply with the general setup and safety regulations on handling and assembly.



Use suitable assembly and transportation devices.



Prevent incarcerations and contusions by means of suitable protective measures.



Use suitable tools only. If specified, use special tools.



Use lifting devices and tools appropriately.



If necessary, use suitable protective equipment (e.g. goggles, protective footwear, protective gloves).



Do not stand underneath hanging loads.



Remove leaking liquids on the floor immediately to prevent slipping.

### 3 Product description

#### 3.1 General

The servo positioning controller LV-servoTEC S2 1xx (LV-servoTEC servo 2<sup>nd</sup> generation) series devices are intelligent AC servo inverter with substantial parameterisation possibilities and extension options. They are flexible and can be easily adapted to a number of different applications.

The series includes types with single-phase and three-phase supply.

##### Type key:

Example using the LV-servoTEC S2 102

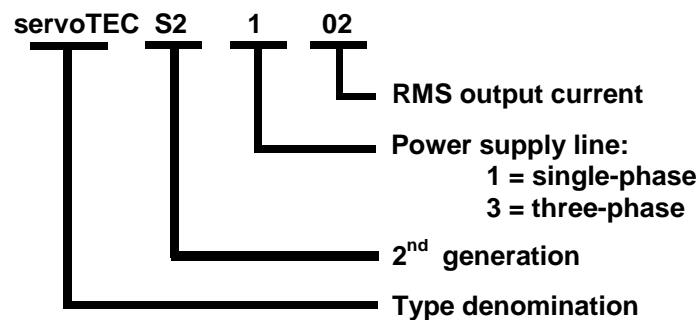

Figure 1: Type key

The single-phase supply types are designed for connection to the 230VAC mains and comprise an active PFC stage (**P**ower **F**actor **C**ontrol). The PFC stage is an active mains current converter required to fulfill the corresponding standards on the limitation of the mains harmonics. The PFC stage also serves the active control of the DC bus voltage. The PFC stage works according to the boost operation principle and provides a nominal DC bus voltage of 360VDC. This voltage is available regardless of the quality of the mains voltage and therefore also in the case of fluctuating main voltages or undervoltage.

This is an important advantage regarding the selection of the servo motor, because, as compared to devices with a passive mains supply, higher rotational speeds can be achieved and/or higher torque constants can be selected. Furthermore, due the active PFC stage, the device is also suitable for varying voltage operation down to 100VAC mains supply; however, the limitation of the active power input due to the allowed maximum current of the PFC stage must be taken into consideration in this case.

All servo positioning controller LV-servoTEC S2 series devices have the following features:

- Space-saving compact design, directly cascable
- High quality of control due to extremely high-quality sensor technology, far superior to conventional market standards, and better than average computer resources
- Complete integration of all components for controller and power module including RS232 interface for PC communication, CAN interface for the integration into automation systems
- Integrated universal encoder evaluation for the following encoders:
  - Resolver
  - Incremental encoder with/without commutation signals
  - High-resolution Stegmann incremental encoders, absolute encoders with Hiperface
  - High-resolution Heidenhain incremental encoders, absolute encoders with EnDat

- Compliance with current european regulations and associated standards without any additional external measures. Device design as per UL standards, UL certification in preparation
- Completely closed, EMC-optimized metal housing for mounting to conventional control cabinet plates. All devices comply with the IP20 system of protection.
- Integration of all filters to fulfill the EMC regulations (industrial) inside the device, e.g. line filter, motor output filter, filter for 24V-supply as well as inputs and outputs
- Integrated brake resistor. External resistors can be connected for higher braking energies.
- Complete galvanic separation of controller and power output stage as per EN50178. Galvanic separation of the 24V potential area with the digital inputs and outputs, analog electronics and the controller electronics.
- Operation as speed controller, torque controller or positioning controller
- Integrated positioning control with wide range of functions as per CAN in Automation (CiA) DSP402 and numerous additional application-specific functions
- Jerk limit or time-optimal positioning relative or absolute to a point of reference
- Point-to-point positioning with or without active positioning profile
- Speed and angle synchronisation with electronic gear system via incremental encoder input or fieldbus
- Extensive modes of operation for synchronisation
- Various methods for homing
- Jogging
- Teach-in mode
- Short cycle times, bandwidth in current control circuit ca. 2 kHz, in speed control circuit ca. 500Hz.
- Switchable clock frequency for the power output stage
- Integrated soft PLC with MDC for customized function changes and extensions
- Freely programmable I/O's
- User-friendly parameterisation with S2Commander™ software
- Menu-driven first set up
- Automatic motor identification
- Easy coupling to host controller, e.g. to a PLC via I/O level or fieldbus
- High-resolution 16-bit analog input
- Technology slots for extensions such as I/O extension module or Profibus interface. It is also possible to insert 2 fieldbus interfaces.
- "Safe Stop" option in accordance with EN 954-1, safety category 3 (integrated in the device).

## 3.2 Power supply

### 3.2.1 Single-phase AC supply with active PFC

The servo positioning controller LV-servoTEC S2 1xx fulfills the following demands on a servo drive controller with active PFC stage:

- Fulfillment of current standards regarding mains harmonics (EN 61000-3-2)
- $\cos\varphi > 0.97$  at nominal operation (at rated output power of the PFC stage)
- Sinusoidal mains current, harmonic distortion  $< 4\%$  (at rated output power of the PFC stage)
- Controlled average value of DC bus voltage of 360VDC
- Insensitive in the case of weak mains and short mains interruptions. In such cases the device maintain stable (within the physical possibilities) without malfunctions
- Wide input voltage range, rated voltage 230VAC
- Frequency range nominal 50-60Hz  $\pm 10\%$ .
- Electrical impulse load capacity for possible combination with servo positioning controller LV-servoTEC S2 1xx converters. The device allows dynamic conversion in both directions between motor and generator operation without dead times.
- No parameterisation by user necessary

Behavior during switch-on:

- As soon as the servo positioning controller LV-servoTEC S2 1xx is supplied with the input voltage, the DC bus is loaded slowly ( $< 1s$ ) using the brake resistor as a precharging resistor. During this the PFC remains inactive.
- After precharging of the DC bus the relay is energized and the DC bus is coupled hard to the mains power without the precharging resistor. Subsequently, the PFC stage is activated and the DC bus is boosted to the full DC bus voltage.
- If the DC bus voltage after precharging is too small, because the input mains voltage is below the PFC operation input voltage range, the PFC stage remains inactive and an error message on the seven segment display is shown.
- If the servo positioning controller LV-servoTEC S2 1xx is supplied with less than that nominal voltage of 230VAC, the actual DC bus voltage after the precharge is used to compute a power derating for the PFC stage (see *chapter 4.2 Supply [X9] (Seite 29) in Figure 3*).

Behavior during normal operation and control characteristics:

- During operation the PFC stage controls the power input of the servo positioning controller LV-servoTEC S2 1xx from the supply. Based on an analog closed-loop control the mains current is regulated to a sinusoidal waveform with a phase shift near to  $0^\circ$ . The effective amplitude is adjusted according to the demanded input power.
- A superimposed digital closed-loop control adjust the DC bus voltage to an average value close to 360VDC. The voltage control loop is speeded up by feed-forward control which is derived from the actual motor power during acceleration and deceleration.

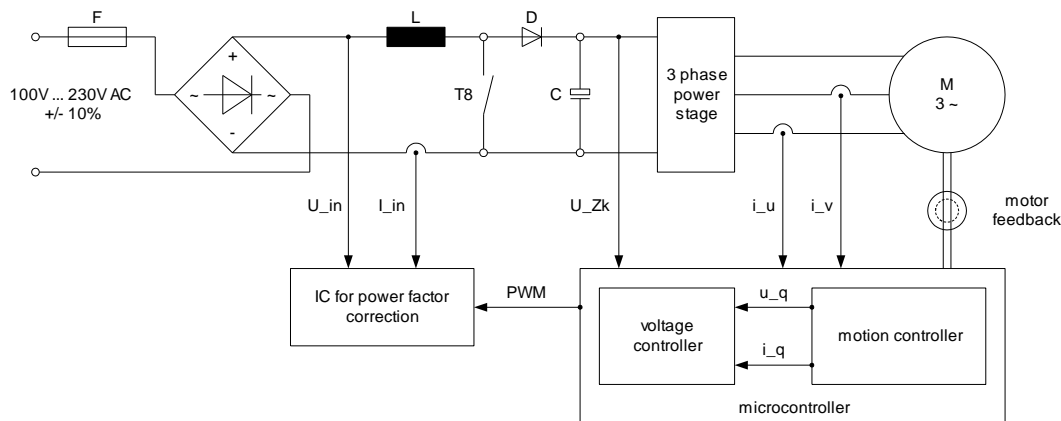

**Figure 2: Schematic setup of PFC stage**

- The control system includes the following values:
  - digital control of the DC bus voltage to an average value of 360VDC
  - analog control of the input mains current
  - Keeping of a sinusoidal mains current under stationary load conditions
  - $\cos\varphi > 0.97$  at nominal operation (at rated output power of the PFC stage)
- By use of the parameterisation program S2Commander the PFC stage (Parameters/Device parameters/PFC) can be switched on and off. With deactivated PFC the DC bus behaves like normal DC bus with a normal rectifier bridge.
- Under stationary load conditions the DC bus voltage is regulated to a constant average value, which is independent from the actual power transferred to the motor.

### 3.2.2 DC bus coupling, DC supply

DC bus coupling:

- It is possible to couple multiple servo positioning controllers of the LV-servoTEC S2 1xx series when they have the same DC bus voltage. For this purpose, the PFC stage has to be deactivated.
- It is possible to couple the servo positioning controller LV-servoTEC S2 1xx series with the servo positioning controller LV-servoTEC S2 series with DC supply. For this, deactivation of the PFC stage is mandatory.



The DC bus coupling of multiple servo positioning controller of the LV-servoTEC S2 1xx series with activated PFC stage is under preparation.

DC supply:

- The direkt DC supply is supported for a supply with voltage  $\geq 60$ VDC by the DC-bus connection instead of the connection to the mains.



The digital motor temperature measurement system requires a DC-link voltage of 230 VDC minimum. Below this voltage, the system will always identify the digital motor temperature sensor as open.

### 3.2.3 Mains fuse

A slow-blow (B16) single-phase automatic circuit breaker of 16 A has to be installed in the mains supply line.



For UL-certifying the following data for the main fuse are to be considered:  
Listed Circuit Breaker according UL 489, rated 277 Vac, 16 A, SCR 10 kA

## 3.3 Brake chopper

A brake chopper with a brake resistor is integrated into the power output stage. If during the generator operation the permissible charging capacity of the DC bus is exceeded, the braking energy can be converted into heat by the internal braking resistor. The brake chopper is software-driven. The internal braking resistor is overload-protected by means of software and hardware.

If in a special application the power of the internal resistors should be insufficient, they can be cut off by removing the bridge between the pin *BR-CH* and *BR-INT* of the [X9] plug. Instead, an external brake resistor is inserted between the pins *BR-CH* and *ZK+*. This brake resistor must fulfill certain minimum specifications (see *Table 10, page 30*). The output is protected against short-circuiting in the brake resistor or its cable.

Pin *BR-CH* lies on positive DC bus potential and is thus not protected against ground fault or short-circuits against mains voltage or negative DC bus voltages.

Simultaneous use of the internal and external brake resistors is not possible. The external resistors are not automatically overload-protected by the device.

## 3.4 Communication interfaces

The servo positioning controller LV-servoTEC S2 1xx has several communication interfaces. The device comprises a RS232 interface, which is crucial for the connection via PC and for using the parameterisation tool S2 Commander™.

The basic unit of the servo positioning controller LV-servoTEC S2 1xx also features a CANopen interface.

PROFIBUS-DP plug-in modules can be used as extension options. Further fieldbus modules are in progress. Customized fieldbus protocols can be realized, if necessary.

In any case, the servo positioning controller of this design always works as a slave to the fieldbus.

### 3.4.1 RS232 interface

The RS232 protocol is mainly intended to be a parameterisation interface, but also allows the control of the servo positioning controller.

### 3.4.2 CAN-Bus

The CANopen protocol as per DS301 with application profile DSP402 is implemented.



The specific CAN protocol of the previous LV-servoTEC S2 devices is no longer supported by the LV-servoTEC S2 1xx series. The servo positioning controller LV-servoTEC S2 1xx supports the CANopen protocol as per DS301 with application profile DSP402.

### 3.4.3 Profibus

Support of Profibus communication as per DP-V1 (DP-V2 under preparation). For drive technology applications the functions as per Profidrive Version 3.0 are available. The features include functions as per Application Class 1 (speed and torque control) as well as per Application Class 3 (point-to-point positioning). Further Profidrive functionalities are in preparation.

It is also possible to include the device into control systems via an I/O mapping via Profibus. From a control point of view, this option offers the same functionality as a conventional PLC coupling via parallel wiring with the device's digital I/Os.

Via a special telegram it is also possible to access all device-specific functions, exceeding the functionality defined by Profidrive.



The profibus profile of the previous LV-servoTEC S2 series is no longer supported by the LV-servoTEC S2 1xx series.

### 3.4.4 I/O functions and device controller

Ten digital inputs provide the elementary control functions (see chapter 4.5.3 I/O interface [X1], page 34):

The LV-servoTEC S2 1xx comprises a target table, in which the positioning targets are stored and from which they can later be retrieved. At least four digital inputs serve the purpose of target selection; one input is used as a start input.

The limit switches serve the safety limitation of the motion space. During a homing one of the two limit switches may serve as a reference point for the positioning control.

Two inputs are used for the power stage enabling on the hardware side as well as for the controller enabling on the software side.

High-speed sample inputs are available for different time-critical applications (homing, special applications...).

The servo positioning controller LV-servoTEC S2 1xx has three analog inputs for input levels in the range of +10V to -10V. One input is designed as a differential input (16 bit), to guarantee high interference immunity. Two inputs (10 bit) are single-ended. The analog signals are quantized and digitalized by an analog-digital converter at a resolution of 16 bit or 10 bit. The analog signals provide the setpoints (speed or torque) for the control.

In common applications the existing digital inputs are already used for basic functions. For the use of further functions such as teach-in mode, separate „start homing“ input or stop input, the analog inputs AIN1, AIN2 as well as the digital outputs DOUT2 and 3, which are also usable as digital inputs, can optionally also be used. Alternatively the I/O extension module EA88 can be inserted.

## 4 Technical data

Table 3: Technical data: Ambient conditions and qualification

Range	Value	
Admissible temperature ranges	Storage temperature:	-25°C to +70°C
	Operating temperature:	0°C to +40°C +40°C to +50°C at reduced power 2,5% /K
Admissible installation height	Up to 1000 m above msl, 1000 to 4000 m above msl at reduced power	
Humidity	Relative humidity up to 90%, not bedewing	
Protection class	IP20	
Pollution degree	1	
CE conformity Low-voltage directive: EMC regulation: Current harmonics:	EN 50 178 EN 61 800 – 3 EN 61 000 – 3 – 2	
Certifications	UL	

Table 4: Technical specifications: Dimensions and weight

Type	LV-servoTEC S2 102	LV-servoTEC S2 105
Dimensions H*W*D	200*54,5*200 mm	225*54,5*200 mm
Dimensions of the mounting plate	240*48,5 mm	240*48,5 mm
Weight	2,0 kg	2,1 kg

Table 5: Technical specifications: Cable specifications

Range	LV-servoTEC S2 102	LV-servoTEC S2 105
Maximum motor cable length for interference emission as per EN 61800-3 (corresponds to EN 55011, EN 55022)		
First ambient Switch cabinet assembly (see <i>chapter 7.16 Notes on safe and EMC-compliant installation</i> ) (under the here fulfilled condition of limited availability) (residential area)	$l \leq 10m$	$l \leq 10m$
Second ambient (industrial area)	$l \leq 25m$	$l \leq 25m$
Cable capacity of a phase against shield or between two lines	$C' \leq 200pF/m$	

Table 6: Technical specifications: Motor temperature monitoring

Motor temperature monitoring	Range
Digitaler sensor	Normally closed contact: $R_{cold} < 500 \Omega$ , $R_{hot} > 100 k\Omega$
Analoger sensor	Silicon temperature sensor, e.g. KTY81, 82 or similar $R_{25} \approx 1000 \Omega \dots 2000 \Omega$ $R_{100} \approx 1700 \Omega \dots 3400 \Omega$

## 4.1 Operating and display elements

On the front the servo positioning controller LV-servoTEC S2 1xx has two LEDs and one seven-segment display to indicate the operating status.

Table 7: Display elements and RESET button

Element	Function
Seven-segment display	Display of operating mode and a coded error number in the case of a malfunction
LED1	Operational state
LED2	Status display CAN bus
RESET-Button	Hardware reset for processor

## 4.2 Supply [X9]

Table 8: Technical specifications: Performance data [X9]

Type	LV-servoTEC S2 102	LV-servoTEC S2 105
Supply voltage	1 x 100 .. 230 VAC [ $\pm 10\%$ ], 50...60Hz	
Alternative DC supply	60 .. 380 VDC	
24V supply	24 VDC [ $\pm 20\%$ ] (0,55 A) *	24 VDC [ $\pm 20\%$ ] (0,65 A) *
Intermediate circuit voltage with active PFC (load-dependent )	360 .. 380 VDC	

\*) plus current consumption of a possibly connected holding brake and I/Os

Table 9: Technical specifications: Internal brake resistor [X9]

Type	LV-servoTEC S2 102	LV-servoTEC S2 105
Brake resistance internal	165 $\Omega$	110 $\Omega$
Pulse power	1,1 kW	1,6 kW
Continuous power	10 W	20 W
Threshold limit	440 V	440 V

Table 10: Technical specifications: External brake resistor [X9]

Type	LV-servoTEC S2 102	LV-servoTEC S2 105
Brake resistance external	$\geq 100 \Omega$	$\geq 80 \Omega$
Continuous power	$\leq 250 \text{ W}$	$\leq 500 \text{ W}$
Operating voltage	$\geq 460 \text{ V}$	$\geq 460 \text{ V}$

Table 11: Performance data of PFC stage

Type	LV-servoTEC S2 102	LV-servoTEC S2 105
For a nominal supply voltage of 230 VAC [ $\pm 10\%$ ]:		
Continuous power output	500 W	1000 W
Peak power output	1000 W	2000 W

Below the nominal supply voltage, the power output of the PFC stage is reduced linearly. These performance curves are shown in Figure 3.

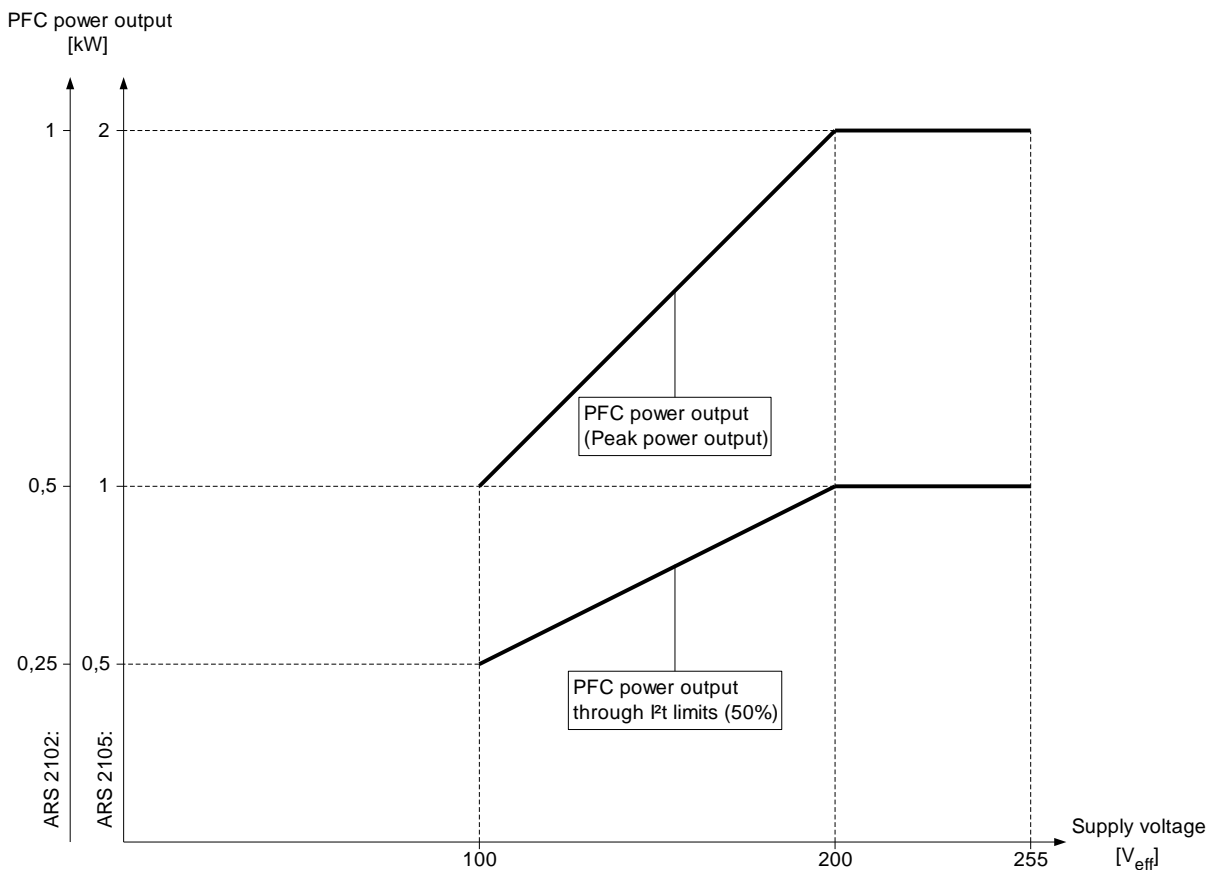

Figure 3: Performance curve of the PFC stage

### 4.3 Motor connection [X6]

Table 12: Technical specifications: Motor connection specifications [X6]

Type	LV-servoTEC S2 102	LV-servoTEC S2 105
Specifications for operation with 1x 230 VAC 50 Hz		
Output power	0,5 kVA	1,0 kVA
Max. output power for 5 s	1,0 kVA	2,0 kVA
Output current	2,5 A <sub>RMS</sub>	5 A <sub>RMS</sub>
Max. output current for 5 s	5 A <sub>RMS</sub>	10 A <sub>RMS</sub>
Clock frequency	max. 13 kHz	max. 13 kHz
Max. mains current for continuous operation	2,4 A <sub>RMS</sub>	4,7 A <sub>RMS</sub>

### 4.4 Motor feedback connection [X2A] and [X2B]

Different feedback systems can be connected to the servo positioning controller LV-servoTEC S2 1xx via the universal encoder interface:

- Resolver (interface [X2A])
- Encoder (interface [X2B])
  - Incremental encoders with analog and digital track signals
  - SinCos encoder (single-turn/multi-turn) with HIPERFACE
  - SinCoder with HIPERFACE
  - Multiturn absolute encoder with EnDat

The encoder type is determined in S2Commander™ parameterisation software.

The feedback signal is available via the incremental encoder output [X11] for master-slave application.

It is possible to evaluate two shaft encoder systems in parallel. Typically, the resolver for the current control is connected to [X2A], and e.g. an absolute encoder is connected to [X2B] as a feedback system for the positioning control.

#### 4.4.1 Resolver connection [X2A]

Common resolvers are evaluated at the 9-pole D-Sub connector [X2A]. Single-pole and multi-pole resolvers are supported. The user must define the resolver pole pair number in the corresponding S2Commander™ menu „Motor data“, so that the LV-servoTEC S2 1xx can properly determine the speed. The pole pair number of the motor ( $P_{0Motor}$ ) is always an integer multiple of the pole pair number of the resolver ( $P_{0Resolver}$ ). Senseless combinations will generate an error message during the identification of the motor, e.g.  $P_{0Resolver} = 2$  and  $P_{0Motor} = 5$ .

The resolver offset angle, which is determined automatically during the identification, is readable and writeable for service purposes.

Table 13: Technical specifications: Resolver [X2A]

Parameter	Value
Transformation ratio	0,5
Carrier frequency	5 to 10 kHz
excitation voltage	7 V <sub>RMS</sub> , short circuit-proof
Impedance excitation (at 10kHz)	$\geq (20 + j20)\Omega$
Impedance stator	$\leq (500 + j1000)\Omega$

Table 14: Technical specifications: Resolver interface [X2A]

Parameter	Value
Resolution	16 Bit
Delay time signal detection	< 200 $\mu$ s
Speed resolution	ca. 4 min <sup>-1</sup>
Absolute accuracy of angle detection	< 5'
Max. rotational speed	16.000 min <sup>-1</sup>

#### 4.4.2 Encoder connection [X2B]

At the 15-pole D-Sub connection [X2B], motors with encoder can be fed back. The possible incremental encoders for the encoder connection are divided into several groups. If you want to use other types of encoders, please contact your sales representative.

##### Standard incremental encoders without commutation signals <FW3.x>:

This type of encoder is used with low-cost linear motor applications, to save the costs for the provision of the commutation signals (hall sensor). With this type of encoder the servo positioning controller LV-servoTEC S2 1xx must carry out an automatic pole position determination after power-on.

##### Standard incremental encoders with commutation signals <FW3.x>:

These are standard incremental encoders with three binary hall sensor signals. The number of lines of the encoder can be freely parameterized (1 – 16384 lines/rotation).

There is an additional offset angle for the hall sensor signals. It is determined during motor identification or can be set via the parameterisation software. In general, the hall sensor offset angle is zero.

##### Stegmann encoders <FW3.x>:

Single-turn and multi-turn shaft encoders with HIPERFACE made by Stegmann are supported. The following series of encoders can be connected:

- Single-turn SinCos encoders: SCS 60, SCS 70, SKS 36, SR 50, SR 60
- Multi-turn SinCos encoders: SRM 50, SRM 60, SKM36, SCM 60, SCM 70
- SinCos encoders for hollow-shaft motor drives: SCS-Kit 101, SCM-Kit 101, SHS 170

SinCoder<sup>®</sup> encoders like SNS50 or SNS60 are no longer supported.

Heidenhain encoders <FW3.x>:

Incremental and absolute encoders by Heidenhain are evaluated. The following series of encoders can be connected:

- Heidenhain ERN1085, ERN 1387, ECN1313, RCN220, RCN 723, RON786, ERO1285, etc.
- Encoders with EnDat interface.

Table 15: Technical specifications: Encoder evaluation [X2B]

Parameter	Value
Parameterisable number of encoder lines	1 - 16384 lines/revolution
Angular resolution / Interpolation	10 Bit / period
Encoder signals A, B	1 V <sub>PP</sub> differential; 2.5 V offset
Encoder signal N	0.2 to 1 V <sub>PP</sub> differential; 2.5 V offset
Commutation track A1, B1 (optional)	1 V <sub>PP</sub> differential; 2.5 V offset
Input impedance encoder signals	Differential input 120 Ω
Limit frequency	f <sub>Limit</sub> > 400 kHz (high-res. signal) f <sub>Limit</sub> ca. 10 kHz (commutation track)
Additional communication interface	EnDat (Heidenhain) and HIPERFACE (Stegmann)
Output supply	5 V or 12 V; max. 300 mA; current-limited control via sensor lines Setpoint programmable via SW

## 4.5 Communication interfaces

### 4.5.1 RS232 [X5]

Table 16: Technical specifications: RS232 [X5]

Communication interfaces	Value
RS232	As per RS232 specification, 9600 Baud to 115.2kBaud

### 4.5.2 CAN bus [X4]

Table 17: Technical specifications: CAN bus [X4]

Communication interfaces	Value
CAN controller	ISODIS 11898, full CAN controller, max. 1Mbaud
CAN protocol	CANopen as per DS301 and DS402

### 4.5.3 I/O interface [X1]

Table 18: Technical specifications: Digital inputs and outputs [X1]

Inputs/outputs	Specifications	
Signal level	24V (8V...30V) active high, conforming with EN 1131-2	
Logic inputs general	Bit 0 \ Bit 1, \ Target selection for positioning Bit 2, / 16 targets selectable from target table Bit 3 /	
DIN4	Control input stage enable at High	
DIN5	Controller enable at High, clear error high-low transition at Low	
DIN6	End switch input 0	
DIN7	End switch input 1	
DIN8	Control signal Start positioning	
DIN9	Home switch for homing or saving of positions	
Logic outputs general	Galvanically separated, 24V (8V...30V) active high	
DOUT0	Operational state	24 V, max. 100 mA
DOUT1	Freely configurable	24 V, max. 100 mA
DOUT2	Freely configurable, optional use as input DIN10	24 V, max. 100 mA
DOUT3	Freely configurable, optional use as input DIN11	24 V, max. 100 mA
DOUT4 [X6]	Holding brake	24 V, max. 1 A

Table 19: Technical specifications: analog inputs and outputs [X1]

Analog in-/outputs	Values	
High-resolution analog input: AIN0	$\pm 10\text{V}$ input range, 16 Bit, differentially, < 250 $\mu\text{s}$ delay time	
Analog input: AIN1	Optionally, this input can also be parameterized as digital input DIN AIN1 with a switching threshold at 8V.	$\pm 10\text{V}$ , 10 Bit, single ended, < 250 $\mu\text{s}$ delay time
Analog input: AIN2	Optionally, this input can also be parameterized as digital input DIN AIN2 with a switching threshold at 8V.	$\pm 10\text{V}$ , 10 Bit, single ended, < 250 $\mu\text{s}$ delay time
Analog outputs: AOUT0 and AOUT1	$\pm 10\text{V}$ output range, 9 bit resolution, $f_{\text{Limit}} > 1\text{kHz}$	

#### 4.5.4 Incremental encoder input [X10] <FW3.x>

The input supports all common incremental encoders.

For example encoders corresponding to the industry standard ROD426 by Heidenhain or encoders with single-ended TTL outputs as well as open collector outputs.

Alternatively, the A and B encoder signals are interpreted by the device as pulse-direction signals, so that the controller can also be driven by stepping motor control boards.

Table 20: Technical specifications: Incremental encoder input [X10]

Parameter	Value
Parameterisable line count	1 – 2 <sup>28</sup> lines / revolution
Trace signals: A, #A, B, #B, N, #N	In accordance with RS422 specification
Max. input frequency	1 MHz
Pulse direction interface: CLK, #CLK, DIR, #DIR, RESET, #RESET	In accordance with RS422 specification
Supply output	5 V, 100 mA max.

#### 4.5.5 Incremental encoder output [X11] <FW2.0>

The output provides incremental encoder signals for processing in superimposed controls.

The signals are generated from the encoder's angle of rotation with a freely programmable number of lines.

Besides the encoder signals A and B, the emulation also provides a reset pulse, which goes to high once per rotation (for the programmed number of lines), for the duration of a ¼ signal period (as long as the encoder signals A and B are high).

Table 21: Technical specifications: Incremental encoder output [X11]

Parameter	Value
Number of lines	Programmable 1 – 16384 lines / revolution.
Connection level	Differential / RS422 specification
Encoder signals A, B, N	As per RS422 specification
speciality	N-Trace disconnectible
Output impedance	$R_{a,diff} = 66 \Omega$
Limit frequency	$f_{Limit} > 1,8 \text{ MHz}$ (lines/s)
Edge triggering (minimum pulse width)	Can be limited by parameters
Output supply	5 V, max. 100 mA

## 5 Function overview

### 5.1 Motors

#### 5.1.1 Synchronous servo motors

Typically, permanently excited synchronous motors with sinusoidal EMF are used. The servo positioning controller LV-servoTEC S2 1xx is a universal servo drive controller, which can be operated with standard servo motors. The motor specifications are determined and parameterized by means of an automatic motor identification.

#### 5.1.2 Linear motors <FW3.x>

Besides rotary applications, the servo positioning controller LV-servoTEC S2 1xx are also suitable for linear drives. Here also, permanently excited synchronous linear motors are supported. Due to the high signal processing quality, the LV-servoTEC S2 series is particularly suitable for driving air-core and iron-core synchronous motors with low motor inductances (2..4mH).

## 5.2 Functions of the servo positioning controller LV-servoTEC S2 1xx

### 5.2.1 Compatibility

For compatibility reasons, from the user's point of view, the control structure of the LV-servoTEC S2 1xx has mostly the same characteristics, interfaces and parameters as the previous LV-servoTEC S2 family.

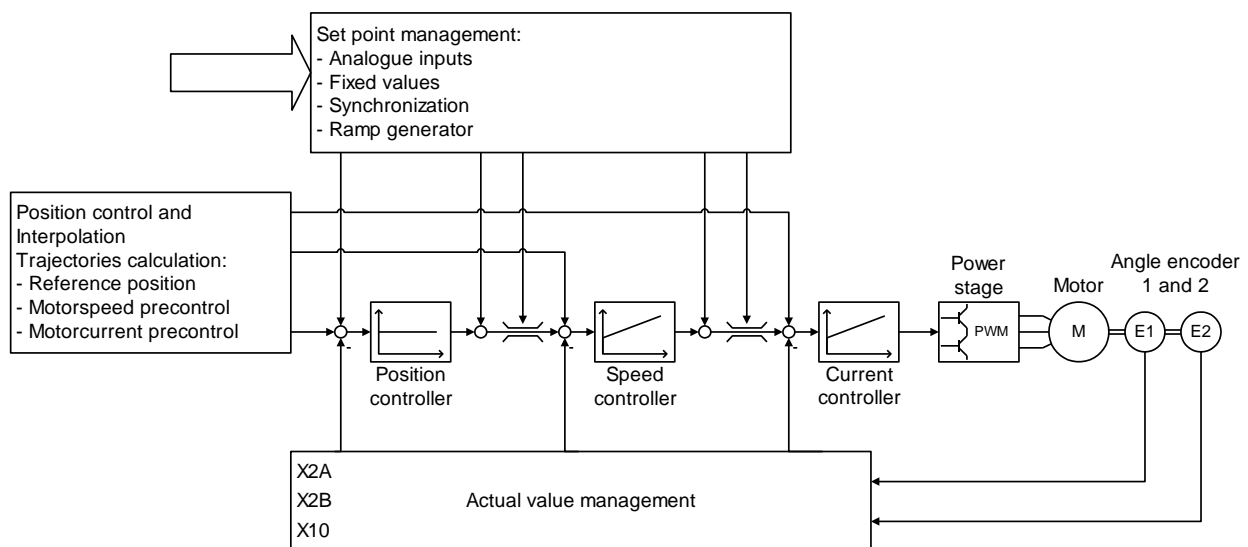

**Figure 4: Control scheme of the LV-servoTEC S2 1xx**

Figure 4 shows the basic control structure of the LV-servoTEC S2 1xx. Current controller, speed controller and positioning controller are arranged in a cascade. Due to the rotor-oriented control principle the current can be set separated in active current ( $i_q$ ) and reactive current ( $i_d$ ). Therefore there are two current controllers, both of them PI controllers. To provide a better overview, however, the  $i_d$  controller does not appear in Figure 4. The planned basic modes of operation are torque control with torque limitation, speed control with torque limitation and positioning. Functions such as synchronisation, „flying saw“, etc. are variants of these basic modes of operation.

## 5.2.2 Pulse width modulation (PWM)

It is possible to vary the clock frequency of the servo positioning controller LV-servoTEC S2 1xx. In most cases the settings can be made using the parameterisation software S2Commander™. In order to minimize switching losses, the clock of the pulse width modulation can be cut in half as compared to the frequency in the current controller circuit.

The servo positioning controller LV-servoTEC S2 1xx also features a sine modulation or alternatively a sine modulation with third harmonic. This increases the effective converter output voltage. The type of modulation can be selected via the S2Commander™. The default setting is sine modulation.

Table 22: Output voltage at the motor terminals at  $U_{ZK} = 360V$

Output voltage converter	Output voltage at the motor terminals
$U_{A,(sin)}$	$U_{LL, Motor} = \text{ca. } 210V_{RMS}$
$U_{A,(sin+sin3x)}$	$U_{LL, Motor} = \text{ca. } 235V_{RMS}$

## 5.2.3 Setpoint management

For speed controlled and torque controlled modes of operation, the setpoint can be set via a setpoint management.

Possible setpoint sources are:

- 3 analog inputs:
  - AIN 0, AIN 1 and AIN 2
- 3 fixed values:
  - 1<sup>st</sup> value: setting depending on controller enabling logic:
    - fixed value 1 or
    - RS232 interface or
    - CANopen bus interface or
    - PROFIBUS-DP interface <FW3.x> or
    - SERCOS interface <FW3.x>
  - 2<sup>nd</sup> and 3<sup>rd</sup> value: setting of fixed values 2 and 3
- Process controller <FW3.x>
- SYNC input <FW3.x>
- Additional incremental encoder input [X10] <FW3.x>



If no setpoint source is activated, the setpoint is zero.

The setpoint management has a ramp generator with a preceding adder. Any of the above-mentioned setpoint sources can be selected via the corresponding selectors and run through the ramp generator. Additional sources can be selected as setpoints using two more selectors. These, however, cannot be run through the ramp generator. The total setpoint is then a summation of all values. The acceleration and deceleration times of the ramp are directionally parameterisable

#### 5.2.4 Torque-controlled mode

In torque control mode a certain setpoint torque is set, which the servo positioning controller generates in the motor. In this case only the current controller is activated, since the torque is proportional to the motor current

#### 5.2.5 Speed-controlled mode

This mode of operation is used, if the motor speed is to be kept constant regardless of the acting load. The motor speed exactly follows the speed set by the setpoint management.

The cycle time of the speed control loop for the servo positioning controller LV-servoTEC S2 1xx is twice the PWM period duration, thus typically 200µs. However, it can also be set as an integer multiple of the current controller cycle time.

The speed controller is a PI controller with an internal resolution of 12 bits per rpm. In order to eliminate wind-up effects, the integrator function is stopped upon reaching subsidiary limitations.

In speed control mode the current controllers and the speed controller are active. In the case of setting via analog setpoint inputs it is optionally possible to define a „safe zero “. If the analog setpoint is within this range, the setpoint is then set to zero („dead zone“). This can suppress interferences or offset drifts. The function of a dead zone can be activated and deactivated and the width can be set.

The setpoints of the speed as well as the actual position are generally determined from the encoder system inside the motor, which is also used for commutation. For the actual value feedback to the speed control any encoder interface may be selected (e.g. reference encoder or corresponding system at external incremental encoder input). The actual speed value for the speed controller is then fed back e.g. via the external incremental encoder input.

The setpoint for the speed can also be set internally or can be derived from the data of an external encoder system (speed synchronisation via [X10] for speed controller).

It is also possible to use values set in a MDC program.

#### 5.2.6 Torque-limited speed control

The servo positioning controllers LV-servoTEC S2 1xx support torque-limited speed-controlled operation with the following features:

- Fast updating of the limit value, e.g. in 200 µs cycle
- Addition of two sources of limitation (e.g. for servo control values)

#### 5.2.7 Synchronization to the external clock signal

The controllers work with sinusoidal constrained-current operation. The cycle time is always bound to the PWM frequency. In order to synchronise the current control to the external clock signal (e.g. SERCOS, Profibus MC) the device has a corresponding PLL. Accordingly the cycle time varies within certain limits, to allow synchronisation to the external clock signal. For synchronisation to an external clock signal the user must enter the rated value of the synchronous cycle time.

#### 5.2.8 Load torque compensation for vertical axes

For vertical axes applications it is possible to detect and store the holding torque during standstill. It is then added to the torque control loop and improves the start-up behavior of the axes after releasing the holding brake.

## 5.2.9 Positioning and position control

In positioning mode a superordinated positioning controller is active in addition to the speed control, which processes deviation of the actual position from the set position and converts it into the corresponding setpoints for the speed controller.

The position controller is a P-controller. By default, the cycle time of the position control circuit is twice the speed controller cycle time. However, it can also be set as an integer multiple of the speed controller cycle time.

When the positioning controller is activated, it receives its setpoints from the positioning or from the synchronisation controller. The internal resolution is up to 32 bits per motor revolution (depending on the used encoder).

The setpoint management also allows the setting of setpoints in MDC programs.

## 5.2.10 Synchronisation, electrical transmissions <FW3.x>

The servo positioning controller LV-servoTEC S2 1xx allows master-slave operation, which in the following will be called synchronisation. The controller can serve as master or slave.

If the servo positioning controller LV-servoTEC S2 1xx is the master, it can provide the slave with its current rotor position at the incremental encoder output [X11]. If the LV-servoTEC S2 1xx controller comprises a communication interface, it can as a master optionally transmit either its current position, speed or both values.

If the servo positioning controller LV-servoTEC S2 1xx is to work as a slave, different inputs are available for synchronisation. An incremental encoder (position synchronisation via [X10] with speed feed forward for the speed controller) or the communication interface can be used as inputs. The speed feed forward can be calculated by the servo positioning controller LV-servoTEC S2 1xx itself. All inputs can be activated/deactivated. The internal encoder can optionally be shut off, if another input is selected as setpoint encoder. This also applies for speed control mode. The external inputs can be weighed with transmission factors. The different inputs can be used individually or simultaneously.

## 5.2.11 Brake management

The servo positioning controller LV-servoTEC S2 1xx can directly actuate a holding brake. The holding brake is operated with programmable delay times. In positioning mode an additional automatic braking function can be activated, which shuts down the power stage of the LV-servoTEC S2 1xx after a parameterized idle time and which lets the brake fall in. This mode of operation is compatible with the functions of the previous LV-servoTEC S2 series of devices.

## 5.3 Positioning control

### 5.3.1 Overview

In positioning mode a certain position is set, which is to be approached by the motor. The current position is derived from the information provided by the internal encoder evaluation. The position deviation is processed in the position controller and is passed on to the speed controller.

The integrated positioning control allows jerk-limited or time-optimal positioning relative or absolute to a point of reference. It provides the position controller and - to improve the dynamics - the speed controller also, with the setpoints.

In the case of absolute positioning a set target position is directly approached. In the case of relative positioning a parameterized route is run. The positioning space of  $2^{32}$  full revolutions allows any number of relative positioning in one direction.

The positioning control is parameterized via a target table. This includes entries for the parameterisation of a target via a communication interface and also target positions, which can be retrieved via the digital inputs. For each entry it is possible to set the positioning method, the driving profile, the acceleration and the deceleration times as well as the maximum speed. All targets can be pre-parameterized. The only thing to do for positioning is then to select an entry and start the action. It is also possible to change the target parameters online via the communication interface.

The servo positioning controller LV-servoTEC S2 1xx provides 256 programmable positioning sets.

The following settings are possible for all positioning sets:

- Target position
- Driving speed
- Final speed
- Acceleration
- Deceleration
- Torque feed forward
- Remaining distance trigger
- Additional flags:
  - Relative / relative to last target / absolute
  - Wait for end / interrupt / ignore start
  - Synchronized
  - Rotary axis: negative direction of rotation <FW3.x>
  - Option: automatic deceleration in case of missing following positioning
  - Option: driving velocity continuously changeable during driving order via analog input <FW3.x>
  - Different options on the setup of path program

The positioning sets can be activated via all bus systems or via the parameterization software S2Commander™. The positioning process can be controlled via digital inputs.

### 5.3.2 Relative positioning

In the case of relative positioning, the target position is added to the current position. Since no fixed zero is required, referencing is not compulsory. It does, however, make sense in many cases, in order to bring the drive to a defined position.

Adding of relative positionings allows for example endless positioning in one direction for a trimming unit or a conveyor belt (incremental dimension). Absolute positioning

The target position is approached independent of the current position. In order to execute an absolute positioning we recommend prior referencing of the drive. In the case of absolute positioning the target position is a fixed (absolute) position referred to the zero or reference point.

### 5.3.3 Driving profile generator

Driving profiles are categorized in time-optimal and jerk-limited positioning. In the case of time-optimal positioning the maximum set acceleration is used for starting and braking. The drive approaches the target in the shortest time possible, the velocity profile is trapezoidal, and the acceleration profile is block-shaped. In the case of jerk-limited positioning the acceleration profile is trapezoidal and the velocity profile is therefore of third order. Since the acceleration changes continuously, the drive is extremely gentle on the mechanics

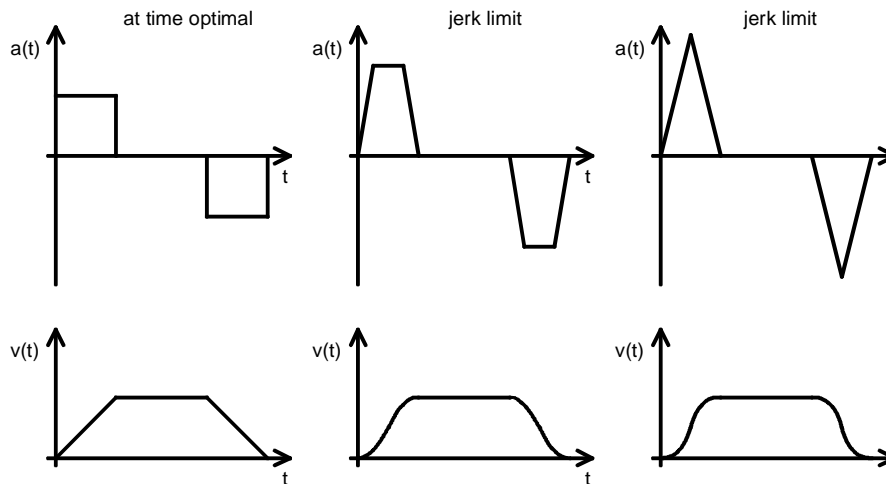

Figure 5: Driving profiles of servo positioning controller LV-servoTEC S2 1xx

### 5.3.4 Homing

Every positioning control requires a defined zero at startup, which is determined by means of a homing. The servo positioning controller LV-servoTEC S2 1xx can do this homing on its own. As reference signals it evaluates different inputs, e.g. the end switch inputs.

A homing can be started by means of a command via the communication interface or automatically with the controller enabling. Optionally a start via a digital input can be programmed using the parameterisation program S2Commander™, to carry out a specific homing independent of the controller enabling. The controller enabling acknowledges e.g. error messages and can be switched off depending on the application, without requiring another homing with a new enabling. Since the existing digital inputs are used in standard applications, the use of the analog inputs AIN1, AIN2 as digital inputs DIN AIN1 and DIN AIN2 as well as the digital outputs DOUT2 and 3 as digital inputs DIN10 and DIN11 are optionally available.

Several methods as per the CANopen manual and following DSP 402 are implemented for the homing. Most methods first search for a switch at search velocity. The further movement depends on the method of communication. If a homing is activated via the fieldbus, there is generally no following positioning to zero. This is done optionally during the start via the controller enabling or RS232. A following positioning is always an option. The default setting is „no following positioning“.

Ramps and velocities are parameterisable for the homing. The homing can also be time-optimal and jerk-limited.

### 5.3.5 Positioning sequences

Positioning sequences consist of a series of positioning sets. These are run consecutively. A positioning set can be made part of a path program by means of its path program options, thus generating a linked list of positions:

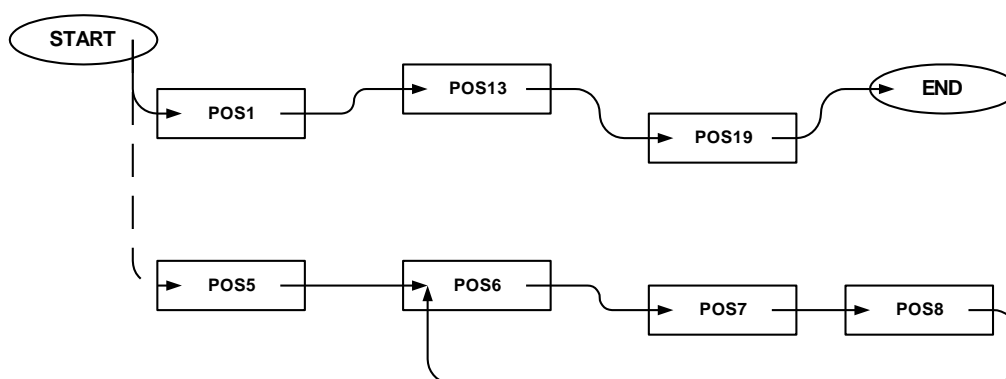

**Figure 6: Path program**

Via the **start position of the path program** the user determines which position series to run. In principle, linear or cyclic series are possible. The end of a sequence of positions is marked by setting the corresponding next position to an “impossible” value (e.g. -1).

The start position of a path program can be determined:

- via fieldbus
- via digital inputs

The number of positions in the corresponding positioning sequence is only limited by the number of totally available positions.

Every position set can be used in the path program. The following settings can be made for all position sets:

- Next position numbers for two successors (more successors possible by forwarding via digital inputs)
- Start delay time
- Waiting for forwarding by digital inputs at end of positioning
- Flag: never stop at this position when path program is cancelled
- Set digital output, when target position is reached / position started

For further information, please refer to the software manual „Servo Positioning Controller LV-servoTEC S2“.

### 5.3.6 Optional stop input

The optional stop input can interrupt the ongoing positioning. Resetting the digital input will resume positioning to the original target position. Since the existing digital inputs are used in standard applications, the use of the analog inputs AIN1, AIN2 as well as the digital outputs DOUT2 and DOUT3, which can also be used as digital inputs, are optionally available.

### 5.3.7 Contouring control with linear interpolation

The implementation of the Interpolated Position Mode allows setting position values in a multi-axis application of the controller. For that purpose set position values are provided by a superordinated control at a fixed time pattern (synchronisation interval). If this interval exceeds a position control cycle, the controller autonomously interpolates the data values between two set position values, as shown in the illustration. The servo positioning controller also calculated a corresponding speed feed forward.

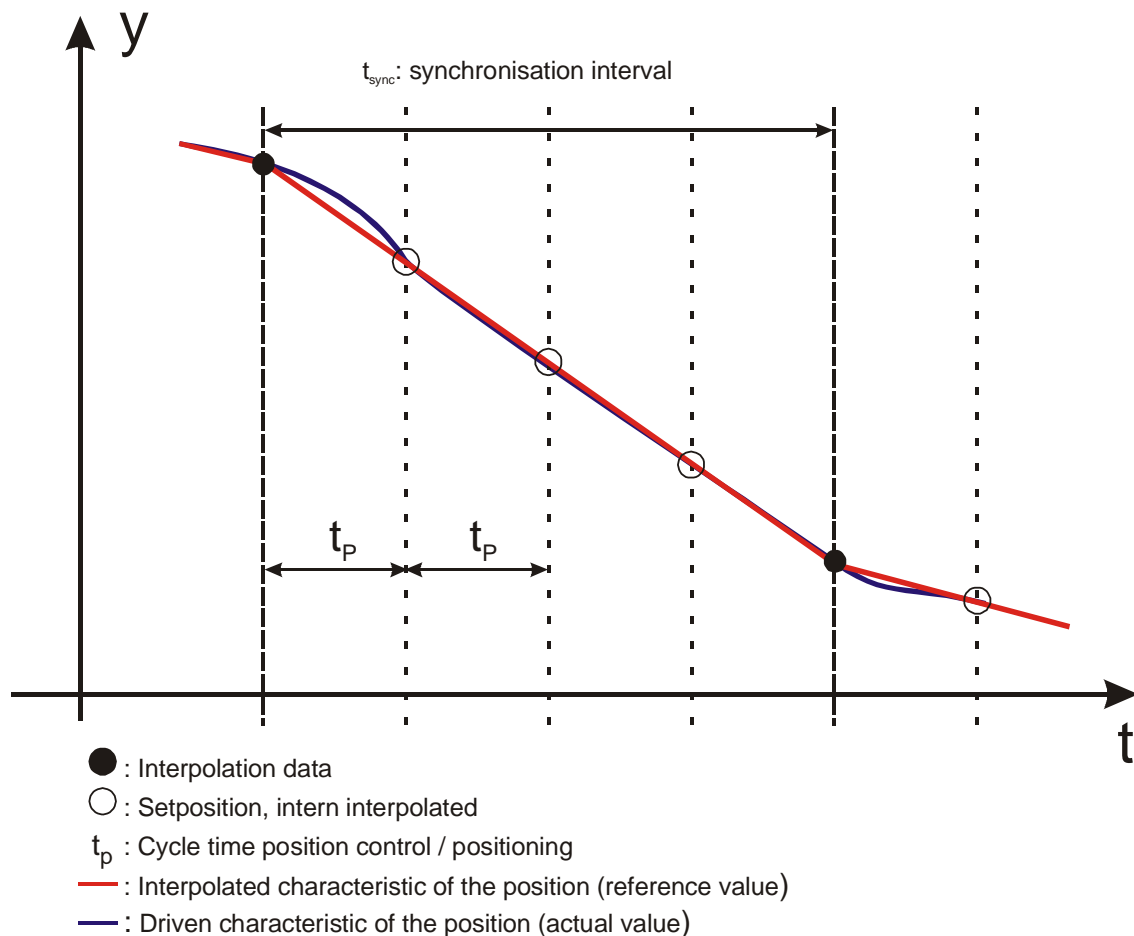

**Figure 7: Linear interpolation between two data values**

---

### 5.3.8 Time-synchronized multi-axis positioning

The implementation of the clock synchronisation allows simultaneous movements for multi-axis applications in conjunction with „interpolated positioning mode“. All controllers of the servo positioning controller LV-servoTEC S2 1xx , i.e. the entire controller cascade, will be synchronized to the external clock signal. Pending positioning values in the case of multiple axes are then taken over and executed simultaneously without jitter. The sync message of a CAN bus system can for example be used as a clock signal.

That way it is e.g. possible to send several axes with different path lengths and velocities to the destination at the same time.

## 6 Functional safety technology

### 6.1 General, intended use

The LV-servoTEC S2 2300 servo positioning controllers support the "safe stop" safety function with prevention of unexpected start-up as required by standard EN 954-1, category 3.

The standstill of the machine has to be initiated and ensured by the control system of the machine. This applies particularly to vertical axes without self-locking mechanism or weight compensation.

In accordance with a danger analysis / risk assessment following the machinery directives 98/37/EEC, EN ISO 12100, EN 954-1 and EN 1050, the machine manufacturer has to plan the safety system for the entire machine whilst taking into account all components integrated. Among these are also electric drives.

The standard EN 954-1 subdivides the requirements placed on control systems into five categories graduated according to the level of risk (see *Table 23*).

Table 23: Description of the requirements to be met for the categories in accordance with EN 954-1

Category <sup>1)</sup>	Summary of requirements	System behaviour <sup>2)</sup>	Principles to achieve safety
B	Safety-related parts of control systems and/or their protective equipments, as well as their components, shall be designed, constructed, selected, assembled and combined in accordance with relevant standards to that they can withstand the expected influence.	The occurrence of a fault can lead to the loss of the safety function.	Mainly characterised by selection of components.
1	The requirements of category B must be met. Well-tried components and well-tried safety principles must be used.	The occurrence of a fault can lead to the loss of the safety function but the probability of occurrence is lower than for category B.	
2	The requirements of category B and the use of well-tried safety principles shall apply. The safety function must be checked by the control system of the machine at regular intervals.	The occurrence of a fault can lead to the loss of the safety function between the checks. The loss of a safety function is detected by the checks.	Mainly characterised by structure

Category <sup>1)</sup>	Summary of requirements	System behaviour <sup>2)</sup>	Principles to achieve safety
3	<p>The requirements of category B and the use of well-tried safety principles shall apply. Safety-relevant parts must be designed as follows:</p> <p>it is not acceptable for a fault in any one of the parts to cause a loss of the safety function.</p> <p>the single fault is detected as soon as possible in a reasonable manner</p>	<p>When a single fault occurs, the safety function will remain intact.</p> <p>Some but not all faults will be detected.</p> <p>Accumulation of undetected faults can lead to the loss of the safety function.</p>	
4	<p>The requirements of category B and the use of well-tried safety principles shall apply. Safety-relevant parts must be designed with two channels; permanent self-monitoring; complete error detection!</p>	<p>When faults occur, the safety function always remains intact.</p> <p>Faults will be detected in time to prevent the loss of the safety function.</p>	

- 1) The categories are not meant to be applied in any given sequence or hierarchic order in terms of safety requirements.
- 2) The risk assessment will indicate whether the total or partial loss of the safety function(s) arising from faults is acceptable.

The standard EN 60204-1 describes possible actions for emergency situations and defines the terms EMERGENCY OFF and EMERGENCY STOP (see Table 24)

Table 24: EMERGENCY OFF and EMERGENCY STOP as per EN 60204-1

Action	Definition (EN 60204-1)	Emergency situation
EMERGENCY OFF	This intervention is used to achieve electrical safety in an emergency situation by disconnecting the electrical power to a complete system or installation or part of it.	An EMERGENCY OFF has to be used if there is a risk of electric shock or another risk caused by electricity.
EMERGENCY STOP	This intervention is used to achieve functional safety in an emergency situation by stopping a machine or moving parts.	An EMERGENCY STOP is used to stop a process or a movement which has become hazardous.

The "safe stop" function will not cause an electrical isolation. It therefore provides no protection against electric shock. It is thus impossible to achieve an EMERGENCY OFF in the normative sense by using the "safe stop" function, because in order to do so, the entire system would have to be shut down via the power switch (main switch or power contactor).

There are three stop categories for an EMERGENCY STOP as per EN 60204-1 which can be used depending on a risk analysis (see Table 25).

Table 25: Stop categories

<b>Stop category 0</b>	Uncontrolled stop. Standstill by immediate disconnection from power.	EMERGENCY OFF or EMERGENCY STOP
<b>Stop category 1</b>	Controlled stop. Power is disconnected when the machine has come to a standstill.	EMERGENCY STOP
<b>Stop category 2</b>	Controlled stop. Power is not disconnected when the machine is at a standstill.	not suitable for EMERGENCY OFF or EMERGENCY STOP

## 6.2 Integrated "safe stop" function



The "safe stop" function does **not** protect against electrical shock. It only offers protection against dangerous rotary motion!

### 6.2.1 General / description of "safe stop" function

The "safe stop" function safely interrupts the power supply to the drive. The drive may not generate any torque and therefore no dangerous rotary motion. In the case of hanging loads additional measures must be taken to safely prevent sagging (e.g. mechanical holding brake). In "safe stop" mode, the standstill position does not have to be monitored.

There are basically three suitable measures to bring about a "safe stop":

- contactor between mains and drive system (power contactor)
- contactor between power section and drive motor (motor contactor)
- safe pulse inhibitor (inhibiting of pulses from power semiconductor, integrated into LV-servoTEC S2 2300)

The use of the integrated solution (safe pulse inhibitor) offers several advantages:

- less external components, e.g. contactors
- less wiring and space needed in switch cabinet
- lower cost

Another advantage is the availability of the system. With the integrated solution the intermediate circuit of the servo controller can remain loaded. As a consequence, there are no significant waiting times for a system restart.

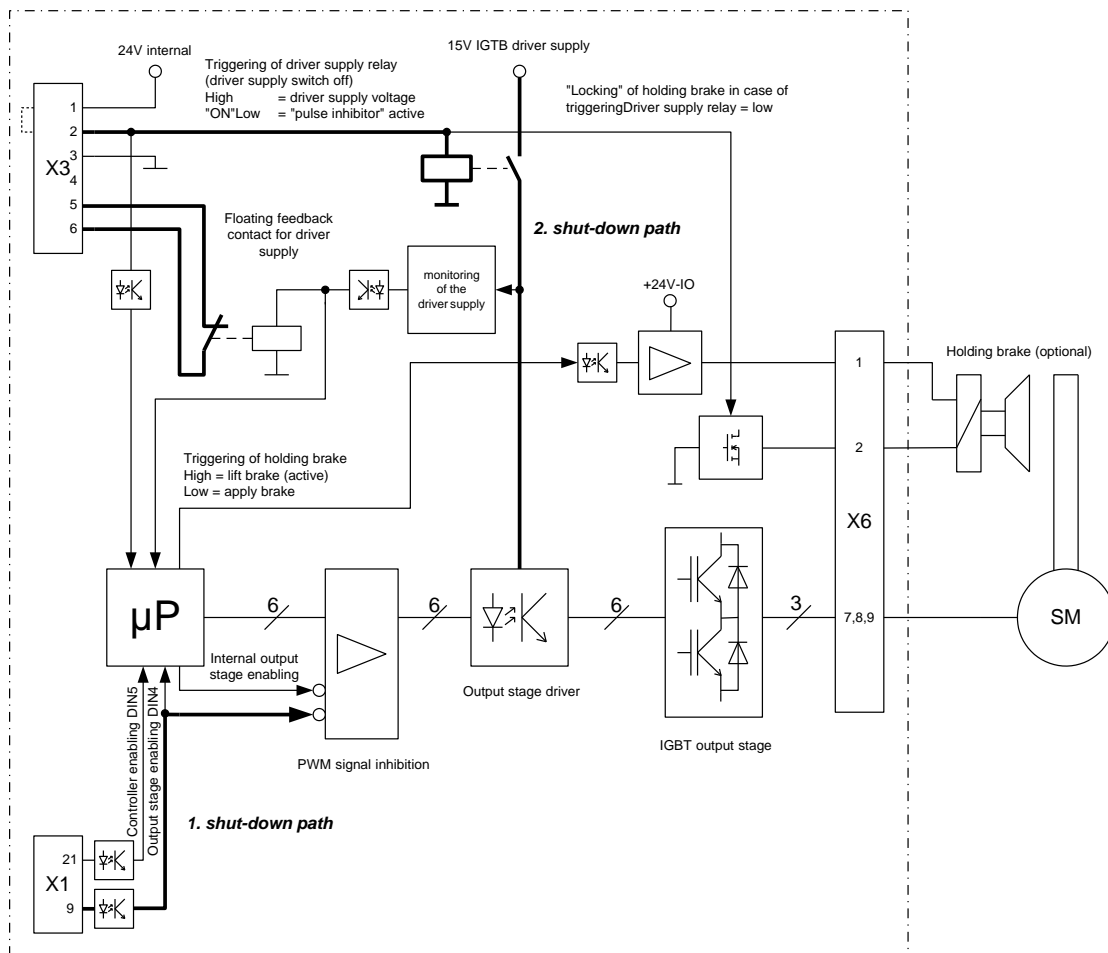

Figure 8: Block diagram "safe stop" as per EN 954-1 category 3



If the "safe stop" function is not needed, bridge pins 1 and 2 to [X3].

A "safe stop" as per EN 954-1 category 3 requires two channels, i.e. a restart must be safely prevented two ways, completely independent of each other. These two ways of interruption, the power supply to the drive and the safe pulse inhibitor, are called shut-down paths.

#### 1. Shut-down path:

Output stage enabling via [X1] (inhibition of PWM signals; the IGBT drivers will no longer be addressed with modulation patterns.)

#### 2. Shut-down path:

Interruption of power supply to the six output stage IGBTs via [X3] by means of a relay (relays will cut the power supply to the IGBT optocoupler drivers to prevent PWM signals from getting to the IGBTs.)

Between the triggering of the output stage supply relay and the monitoring of the driver supply a plausibility test will be performed in the µP. This will detect errors in the pulse inhibitor and will also suppress the error message E-05-2 ("Driver voltage fault") occurring during normal operation.

### 3. Floating feedback contact:

The integrated circuit for the "safe stop" function also has a floating feedback contact ([X3] pins 5 and 6) for the existence of the driver supply. This contact is designed as a normally closed contact. It, for example, has to be connected to the superordinate control. At regular intervals (e.g. PLC cycle or with each "safe stop" request), the PLC has to perform a plausibility check between the triggering of the driver supply relay and the feedback contact (contact open = driver supply available).

In the case of an error during the plausibility check, further operation must be prevented, e.g. by eliminating the controller enabling or by shutting down the power contactor.

### **6.2.2 Safe holding brake activation**

In the case of activation of the "safe stop" function, the holding brake is switched currentless (brake applied); (see block diagram).

#### 1st Channel:

During operation the holding brake is controlled with the DIN5 (controller enabling) (see timing diagram below). The first shut-down path "output stage enabling" acts on the brake driver via the  $\mu$ P and switches the holding brake currentless (brake applied).

#### 2nd Channel:

The second shut-down path "triggering of driver supply relay" directly acts on a MOSFET which deactivates the holding brake (brake applied).



The user is responsible for the dimensioning and the safe functioning of the holding brake. The functioning of the brake must be checked and ensured by means of a suitable brake test.

### 6.2.3 Mode of operation / timing

The following timing diagram shows how the "safe stop" function works in connection with the controller enabling and the holding brake:

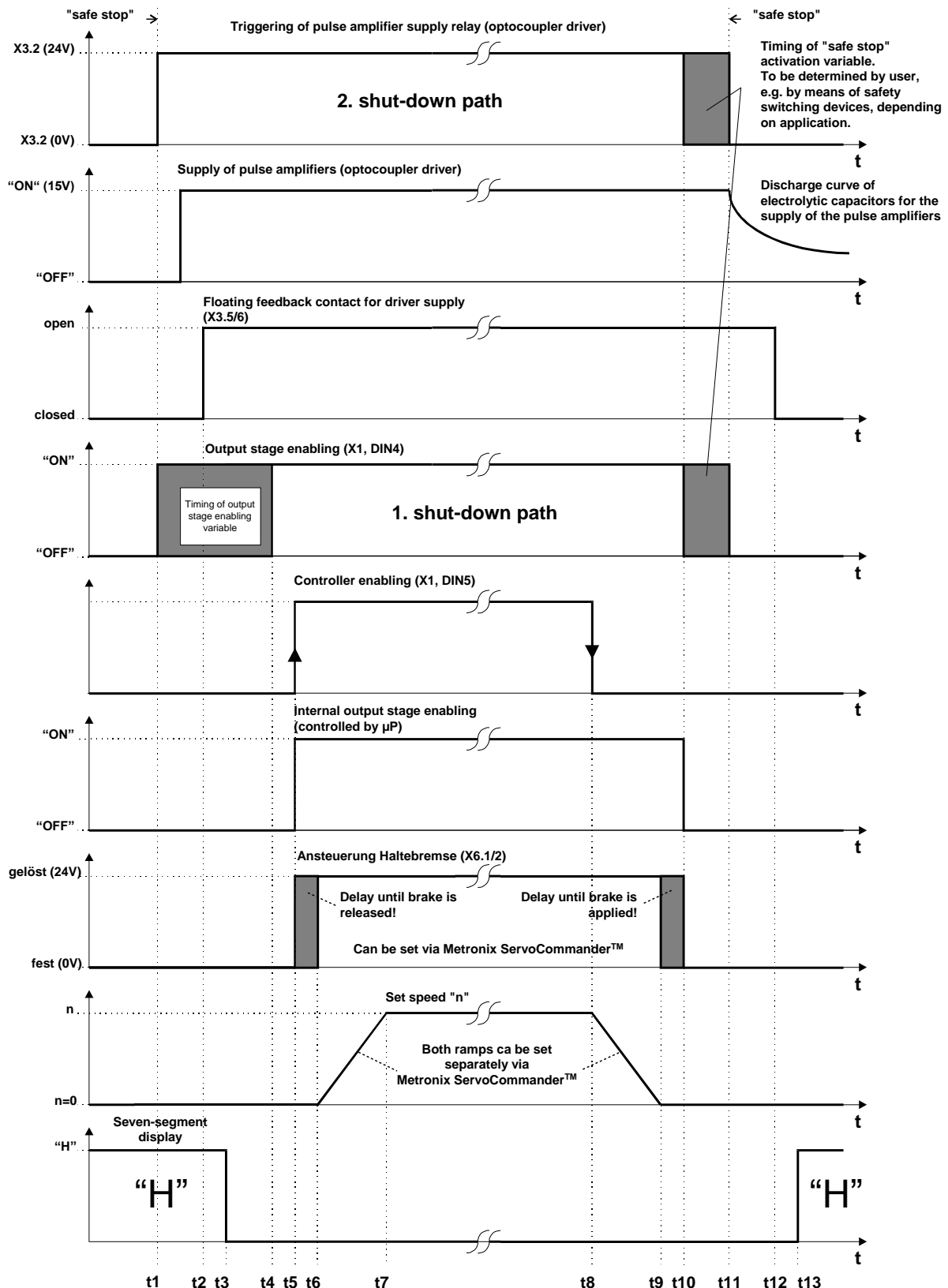

Figure 9: Timing of "safe stop" as per EN 954-1 category 3

Description of the timing diagram:

This timing diagram has been generated using as an example the speed control under consideration of the controller enabling DIN 5 at [X1]. For applications with field buses the controller enabling is also controlled by the respective field bus. Depending on the application, the mode of operation can be parameterized via S2 Commander™.



**Note:**

**In contrast to the functional operation, the “safe stop” mode is marked in BOLD!**

Initial state:

- The 24V supply is switched on and the intermediate circuit has been loaded.
- **The servo controller is in “safe stop” mode. This status is indicated by a flashing “H” on the 7-segment display.**

In order to reactivate the output stage of the servo controller and thus to operate the connected motor, the following steps must be followed:

1. The triggering of the relay that switches the supply voltage of the output stage drivers (2<sup>nd</sup> shut-off path) happens at the time t1 via [X3] with 24V between pins 2 and 3.
2. The driver supply is charged.
3. The floating feedback contact ([X3] pins 5 and 6) for the plausibility check between the triggering of the driver supply relay and the availability of the driver supply is opened no later than 20ms after t1 (t2-t1).
4. Approx. 10ms after the opening of the feedback contact the “H” will disappear from the display at the time t3.
5. The time for the output stage enabling ([X1], DIN4) can for the most part be freely selected (t4-t1): The enabling may be at the same time as the triggering of the driver relay, but must happen approx. 10µs (t5-t4) prior to the rising edge of the controller enabling ([X1], DIN5), depending on the application.
6. With the rising edge of the controller enabling at the time t5 the release of the holding brake of the motor (if available) will be initiated and the output stage will be internally enabled. Releasing the brake is only possible if the triggering of the relay that switches the driver supply is pending, since this will trigger a MOSFET, which is located in the circuit of the holding brake. The parameterization program S2 Commander™ can be used to set a delay (t6-t5). That way the drive will remain at “0” speed for the time set and only after this time has run out at t6, the drive will start approaching the set speed. This delay is set so that the existing holding brake is safely released before the rotary motion starts. For motors without holding brake this time can be set to 0.
7. At the time t7 the drive will have reached the set speed. The necessary ramp settings can be parameterized via ServoCommander™.

The following steps show how to get a rotating drive to a “safe stop”:

1. Before activating the “safe stop” (i.e. driver supply relay “OFF” and output stage enabling “OFF”; both shut-down paths inhibit the PWM signals) the drive should be stopped by deactivating the controller enabling. Depending on the application, the brake ramp ( $t_9-t_8$ ) can be set via S2 Commander™ (“Quick stop deceleration”).



Activation of the “safe stop” function during operation will cause the drive to run down. If the drive has a holding brake it will be activated. It is therefore very important to make sure that the motor brake can actually stop the motion of the drive.

2. After 0 speed has been reached, the drive will be controlled to this set value for a parameterizable drop-out delay time ( $t_{10}-t_9$ ). This parameterizable time is the deceleration, at which the holding brake of the motor is applied. This time depends on the holding brake and must be set by the user. For applications without holding brake this time can be set to 0.
3. After this time has run out, the internal output stage enabling will be switched off by the  $\mu P$  ( $t_{10}$ ).  
The holding brake will definitely be activated as soon as the “brake ramp time + set drop-out delay time” has run out, even if the drive has not yet been able to stop!
4. As of  $t_{10}$  the “safe stop” can be activated (simultaneous deactivation of triggering of driver supply relay and output stage enabling). The time ( $t_{11}-t_{10}$ ) depends on the application and must be set by the user.
5. With the withdrawal of the trigger signal for the relay that switches off the driver supply ( $t_{11}$ ) the capacitors in this voltage branch will be discharged. Approx. 80ms ( $t_{12}-t_{11}$ ) after the withdrawal of the trigger signal for the relay that switches off the driver supply, the feedback contact ([X3], pins 5 and 6) will be closed.
6. At the time  $t_{13}$  the letter “H” will be shown on the 7-segment display of the servo controller for the visualization of the “safe stop” function. This will happen no later than 30ms after the closing of the floating feedback contact ( $t_{13}-t_{12}$ ).

## 6.2.4 Application examples

### 6.2.4.1 Emergency stop circuit:

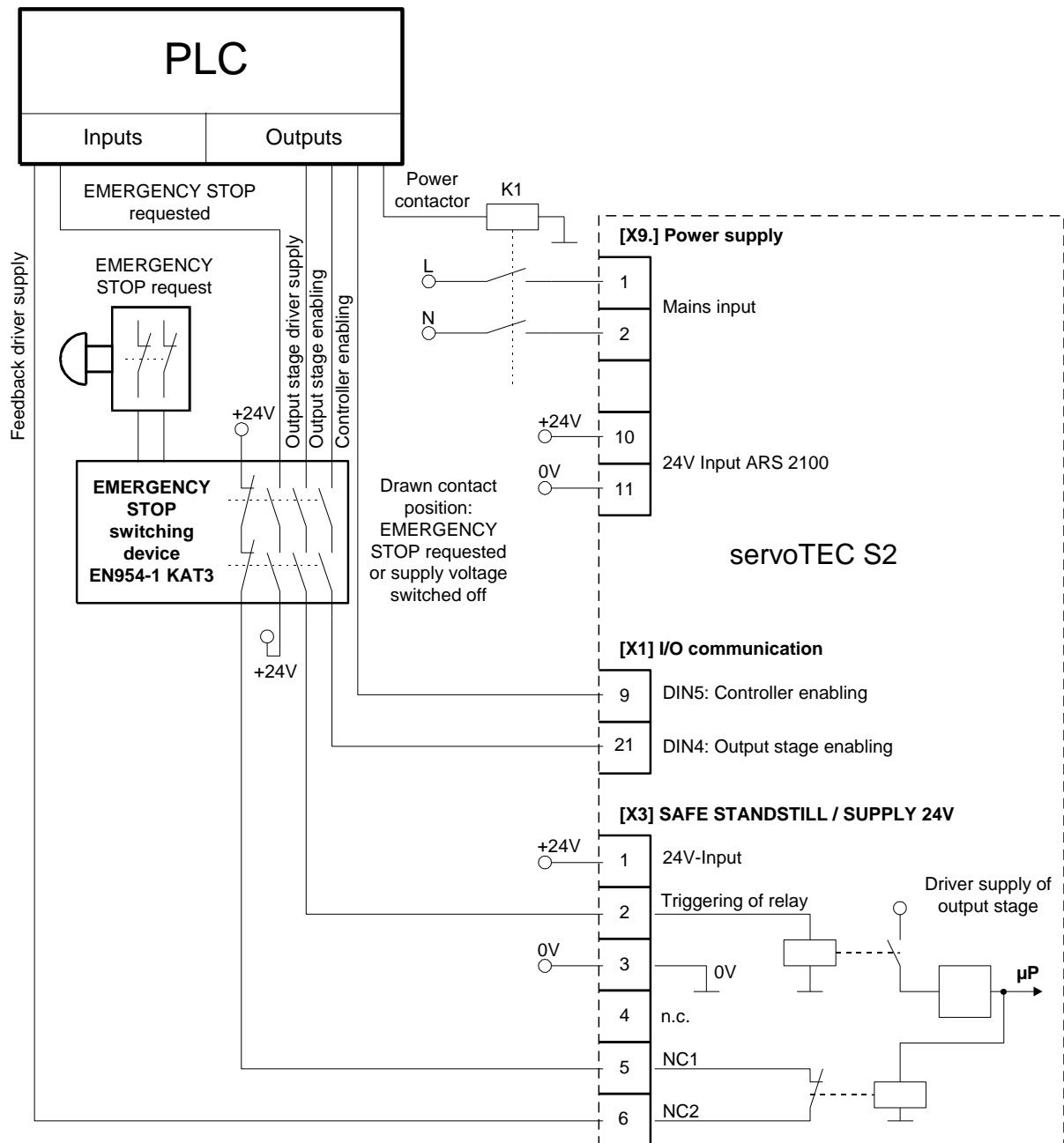

**Figure 10: Emergency-off circuit in accordance with 945-1, category 3, and stop category 0 in accordance with 60204-1.**

Mode of operation:

The EMERGENCY STOP request inhibits the output stage enabling and the triggering of the relay for the driver supply of the IGBT output stage via the EMERGENCY STOP contactor. The drive coasts down and at the same time the holding brake of the motor, if available, is activated.

The servo controller is in “safe stop” mode.

The EMERGENCY STOP contactor has been approved as per EN954-1, safety category 3.

A superordinate control monitors the “EMERGENCY STOP request” and “driver supply feedback” signals and checks them for plausibility. In the case of an error the power contactor will be shut down.

The DC-link voltage remains present and can be used by the drive immediately after deactivation of the EMERGENCY-STOP switching device and after the enabling of the controller.

The connection of the motor and the optional holding brake are not shown here, please refer to *chapter 0 Electrical installation*.



The brake of the motor has to be designed such that it can stop the movement of the drive.

### 6.2.4.2 Safety door monitoring

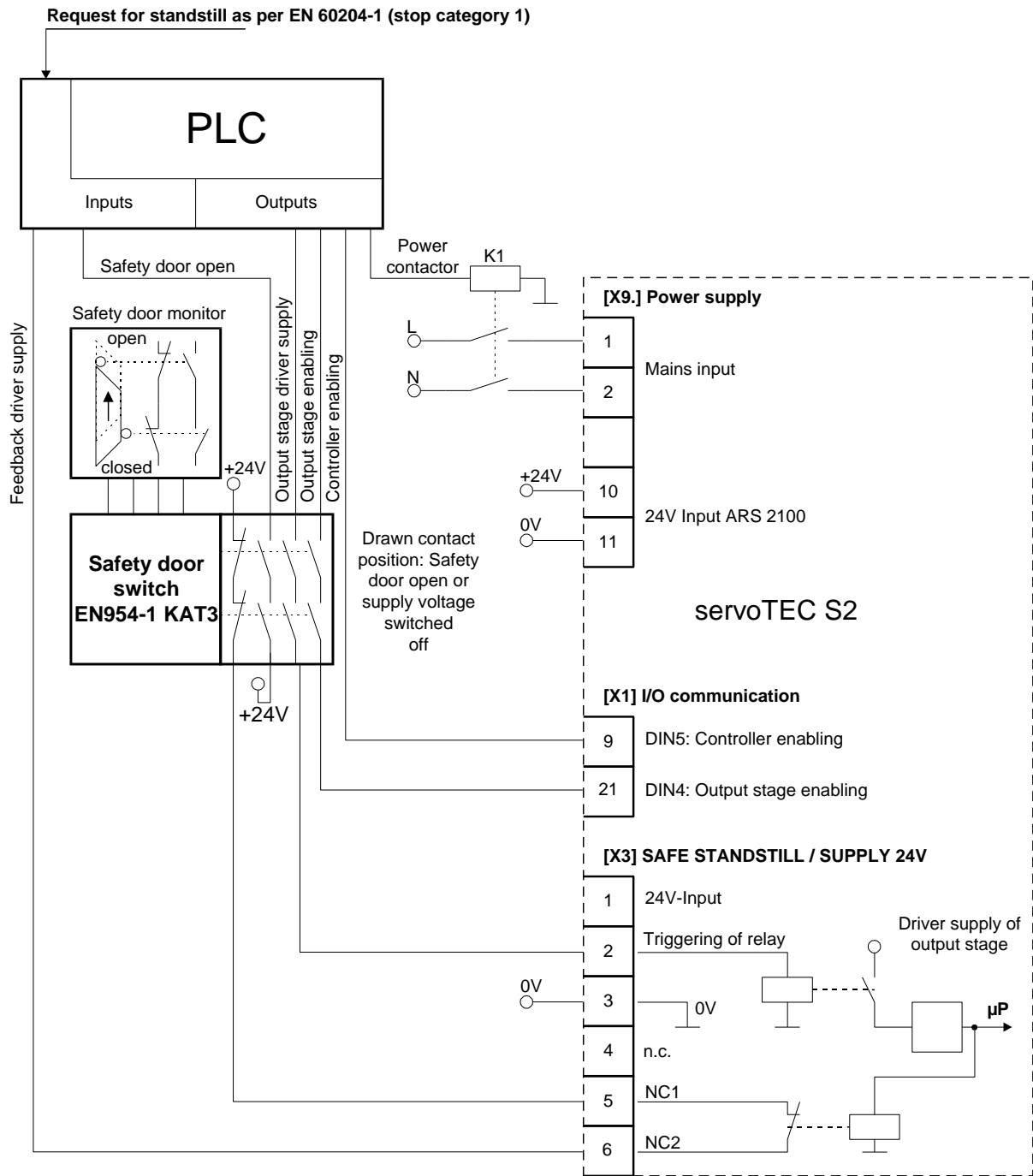

Figure 11: Safety door monitoring in accordance with 945-1, category 3, and stop category 0 in accordance with 60204-1.

### Mode of operation:

The request to stop the drive will set the controller enabling to low.

The drive will approach 0 speed using the set deceleration ramp (parameterizable via S2 Commander™).

After the ramp time (including drop-out delay time of holding brake, if available) has run out, the triggering of the driver supply relay and the controller enabling will be cancelled by the superordinate control.

A superordinate control monitors the “safety door open”, “output stage driver supply output” and the “driver supply feedback” signals and checks them for plausibility. In the case of an error the power contactor will be shut down.

The opening of the safety door will also interrupt the output stage enabling and the triggering of the driver supply relay. The servo controller is in “safe stop” mode and protected against restart.

The safety door switching device has been approved as per EN954-1, safety category 3.

The DC-link voltage remains present and can be used by the drive immediately after the safety door has been closed.

If the safety door is opened without a request for a standstill, the drive will run out as per EN 60204-1 stop category 0 and at the same time the holding brake of the motor will be applied, if available. The drive is in “safe stop” mode and protected against restart.

It is also possible to use a door position switch, which keeps the safety door closed until the drive has come to a complete standstill or the “feedback driver supply” signal indicates the safe mode and the plausibility check have been successfully completed. However, the “safe stop” mode offering protection against restarting is only activated with the opening of the safety door (not shown).

Another possible application is the use of a safety door switching device with delayed contacts. The opening of the safety door has a direct impact on the controller enabling, whose falling edge causes a controlled stopping at a set deceleration ramp. The signals “output stage enabling” and “output stage driver supply” are then switched off with a delay via the safety module. The drop-out delay time must be matched to the deceleration ramp time (not shown).



The brake of the motor has to be designed such that it can stop the movement of the drive.

## 7 Mechanical installation

### 7.1 Important notes

- Only use the servo positioning controller LV-servoTEC S2 1xx as a built-in device for switch cabinets
- Mounting position vertical with supply lines [X9] on top
- Mount to control cabinet plate using a fastening strap
- Installation spaces:  
Keep a minimum distance of 100 mm to other components each above and underneath the device to ensure sufficient venting.
- The servo positioning controller LV-servoTEC S2 1xx may be installed adjacently in one switch cabinet without a gap, proper usage and installation on a heat-dissipating rear panel provided. Please note that excessive heat may cause premature aging and/or damaging of the device. In case the servo positioning controller LV-servoTEC S2 1XX are subject to high thermal stress, a space of 59 mm is recommended!



The connections of the following illustrations for the servo positioning controller LV-servoTEC S2 102 also apply to the servo positioning controller LV-servoTEC S2 105!

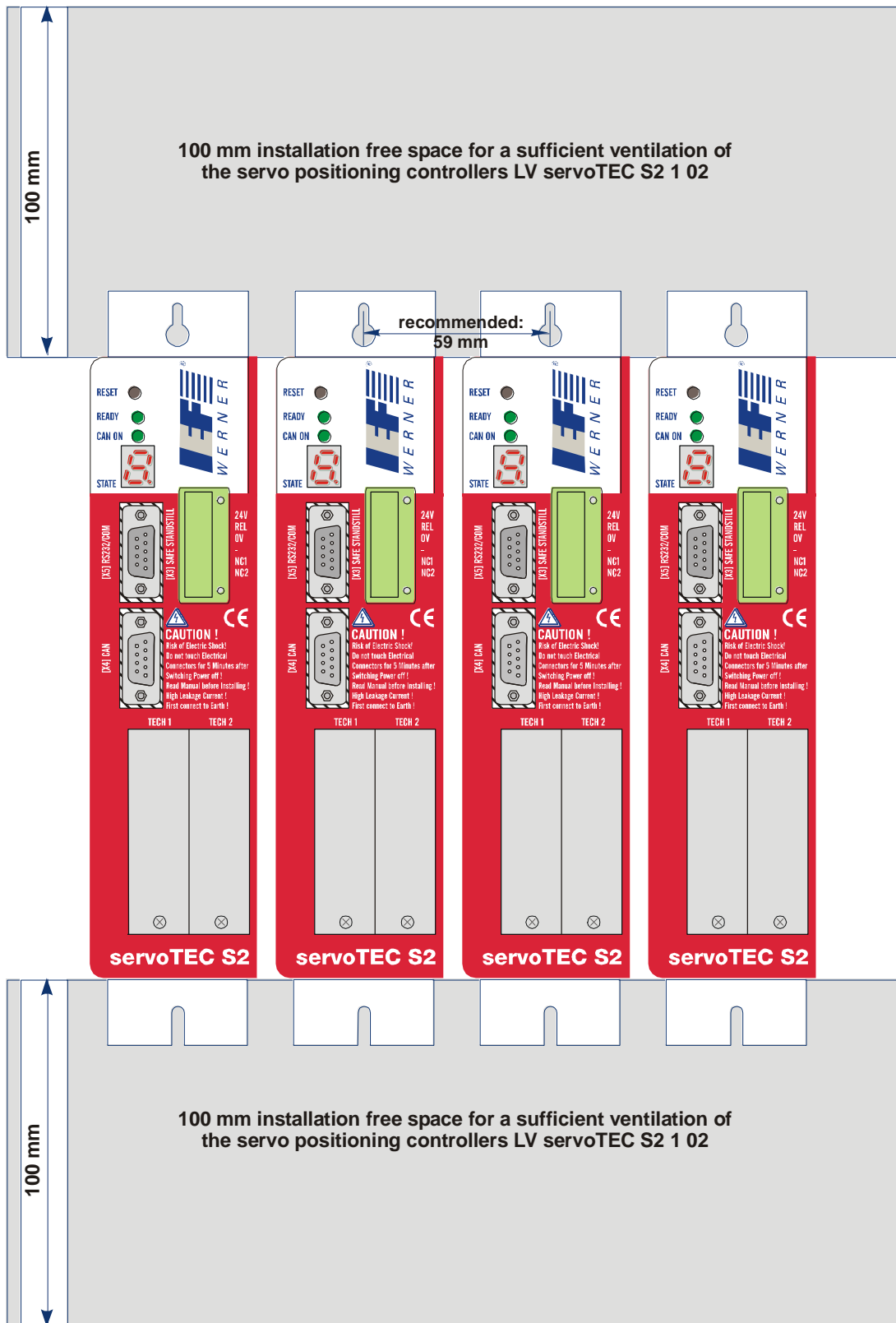

**Figure 12: Servo positioning controller LV-servoTEC S2 1 XX: Installation space**

## 7.2 View of the device

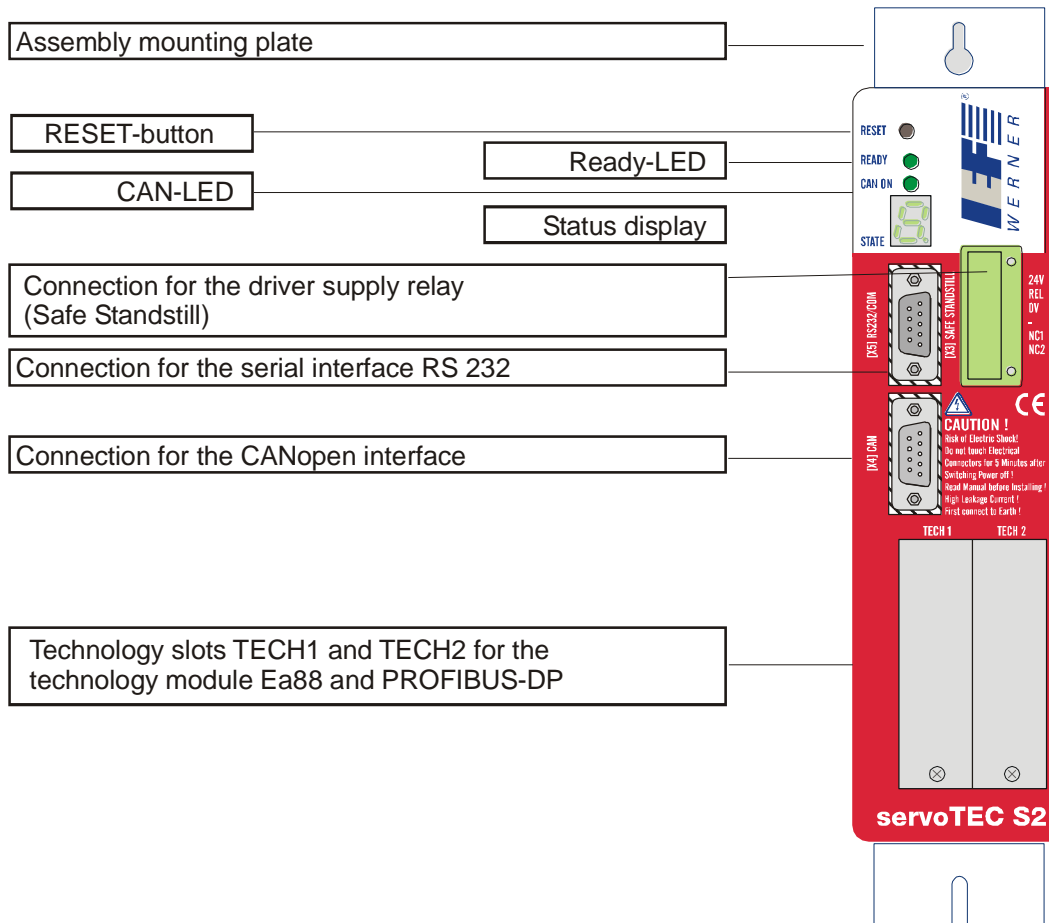
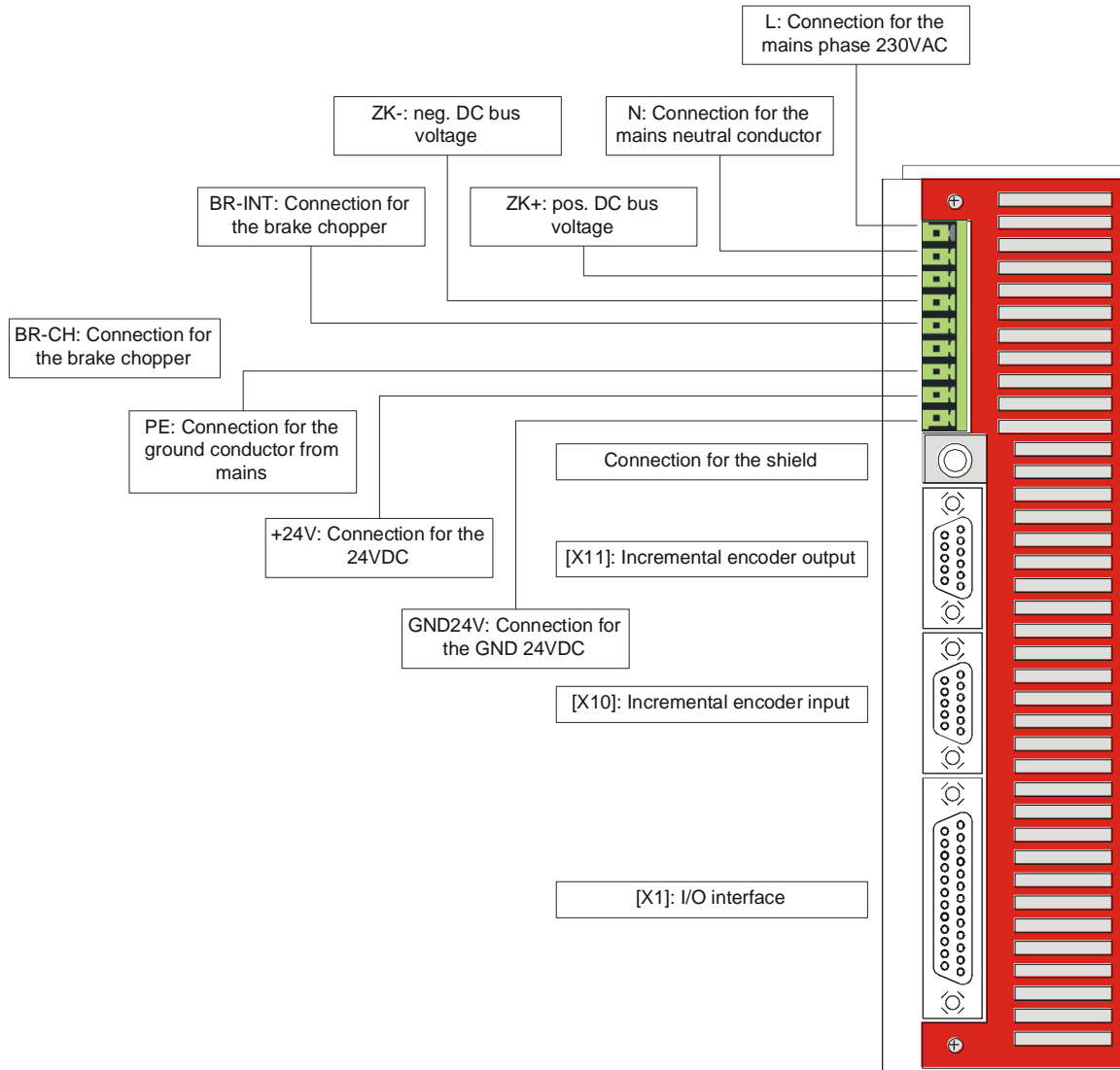
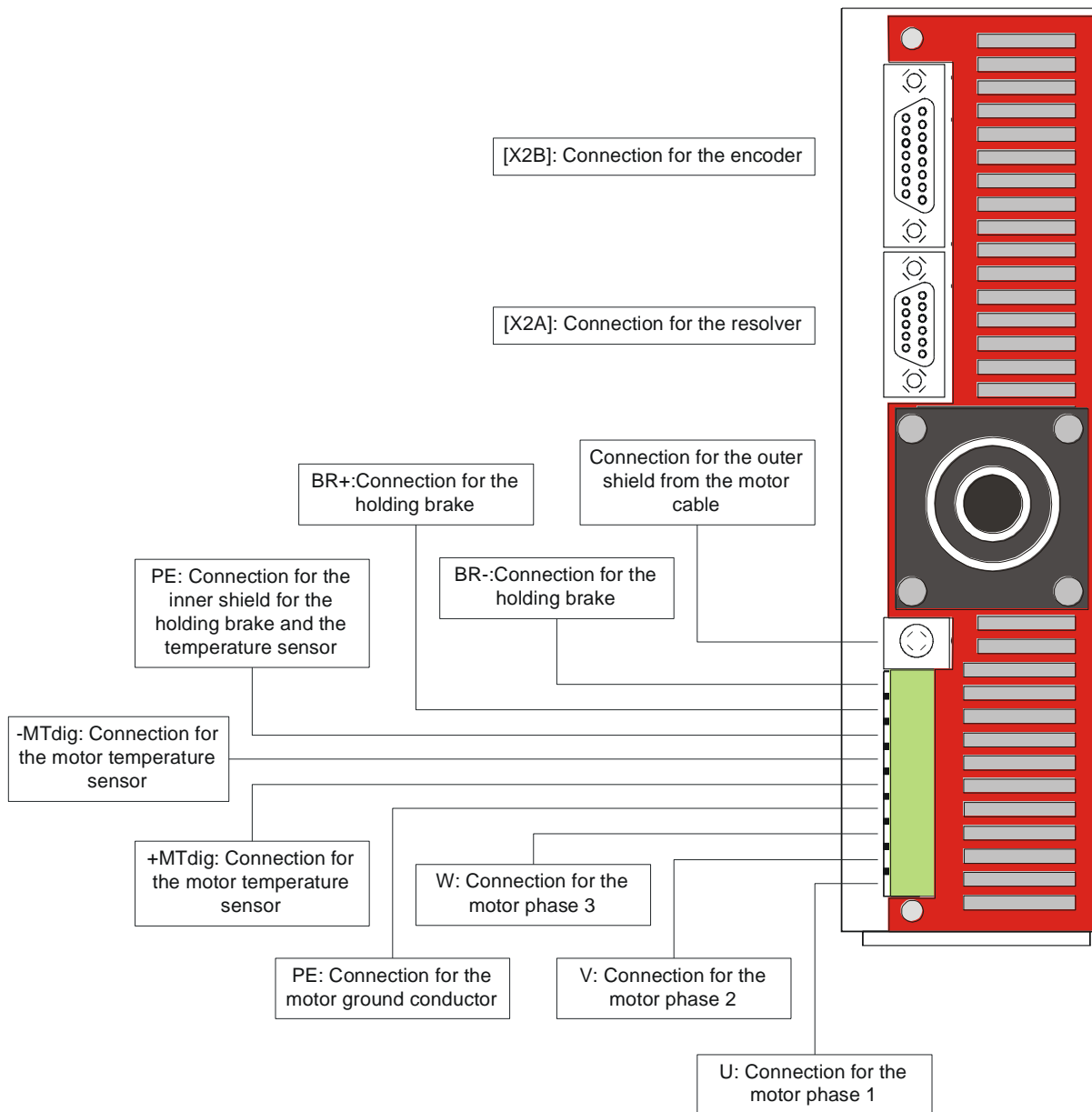

Figure 13: Servo positioning controller LV-servoTEC S2 1 02: Front view



**Figure 14: Servo positioning controller LV-servoTEC S2 1 02: Top view**

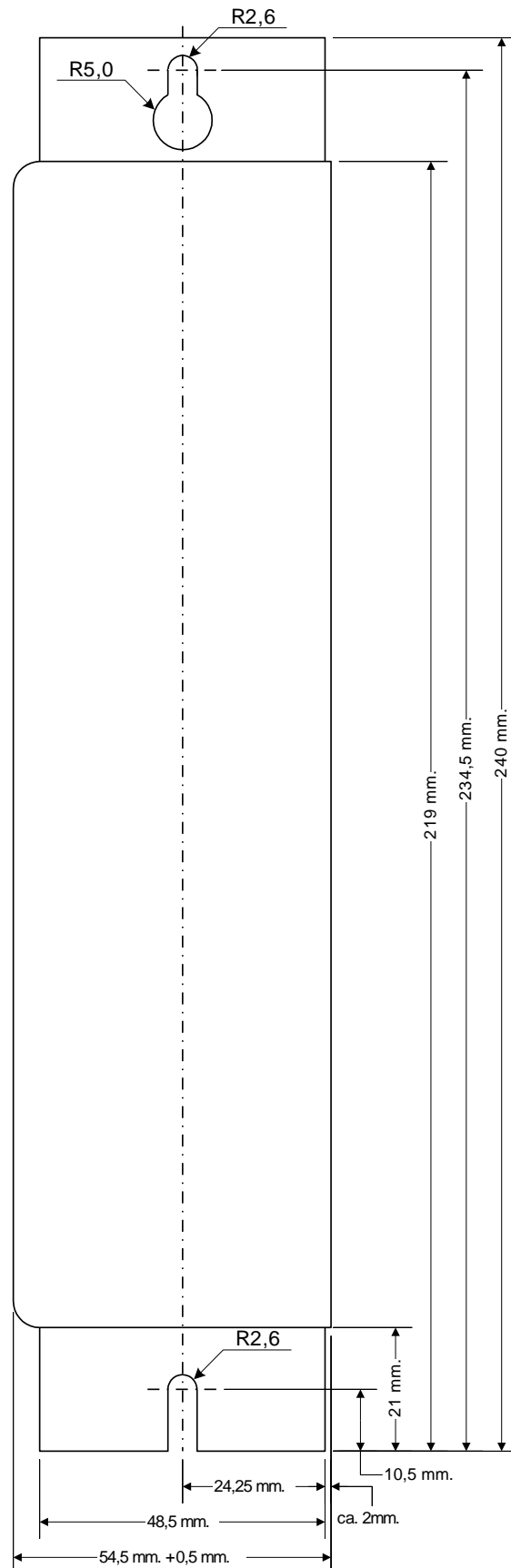

**Figure 15: Servo positioning controller LV-servoTEC S2 102: Bottom view**

### 7.3 Mounting

The servo positioning controller LV-servoTEC S2 1xx has attachment lugs on the top and the bottom of the device. These are used to mount the servo positioning controller vertically to a control cabinet plate. The lugs are part of the cooling body profile, thereby providing optimum heat transmission to the control cabinet plate.

Please use M5 screws for the mounting of the servo positioning controller LV-servoTEC S2 102 und LV-servoTEC S2 105



**Figure 16: Servo positioning controller LV-servoTEC S2 1xx:  
Mounting plate Electrical installation**

## 7.4 Connector configuration

The servo positioning controller LV-servoTEC S2 1xx is connected to the supply voltage, the motor, the brake resistor and the holding brakes as shown in *Figure 17*.

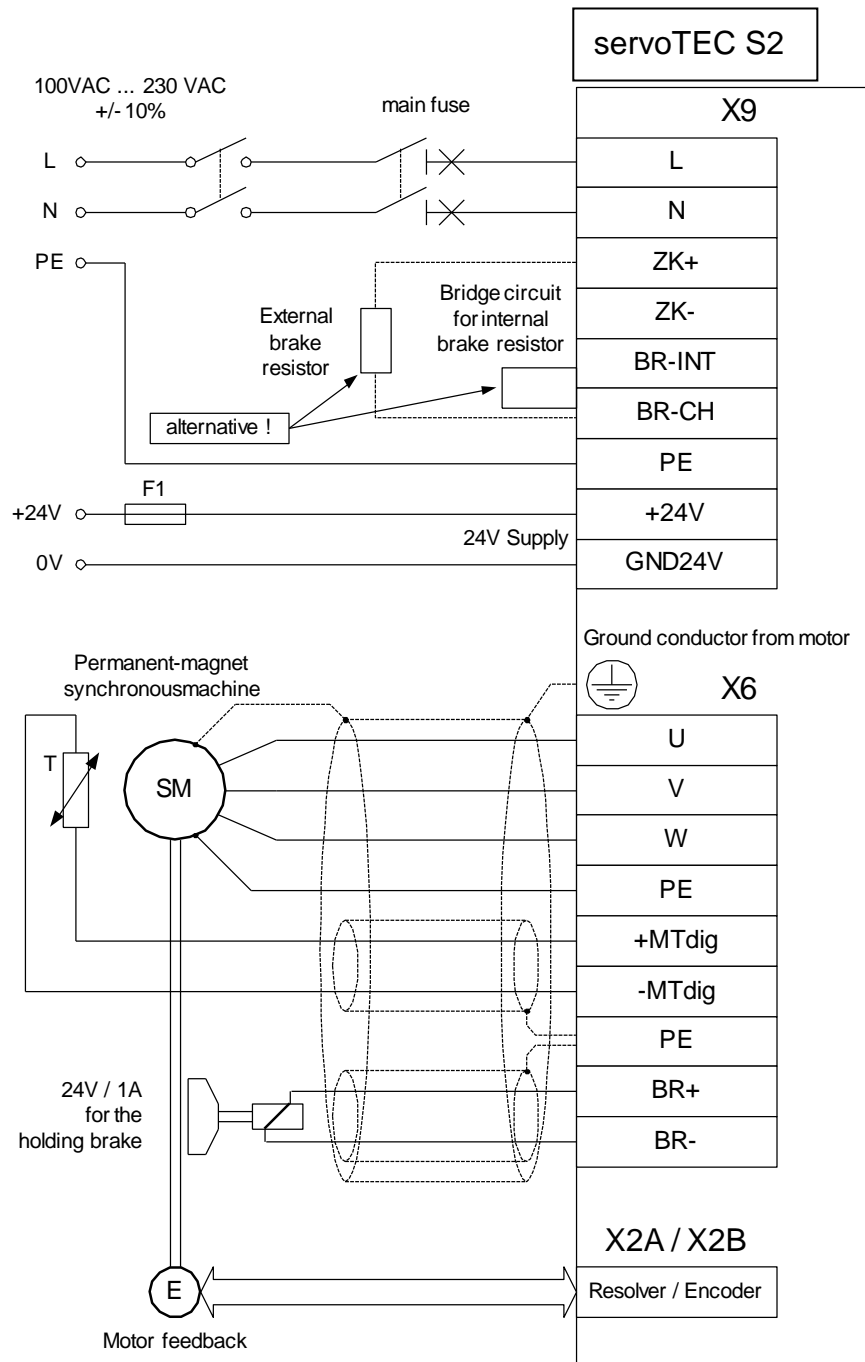

**Figure 17: Connection to power supply and motor**

The operation of the servo positioning controller LV-servoTEC S2 1xx requires a 24V voltage supply source for the electronics supply, which is connected to the terminals +24V and GND24V.

The connection to the supply for the power output stage is either made to terminals L1 and N for AC supply or to ZK+ and ZK- for DC supply.

The motor is connected to terminals U,V,W. The motor temperature switch (PTC or normally closed contact) is connected to terminals +Mtdig and –Mtdig, if it is lead into one cable together with the motor phases. If an analog temperature sensor (e.g. KTY81) is used in the motor, it is connected via the encoder cable to [X2A] or [X2B].

The connection of the shaft encoder via the D-Sub connector to [X2A] / [X2B] is roughly shown in Figure 17.

The servo positioning controller LV-servoTEC S2 1xx must be connected to ground with its PE connection.

The LV-servoTEC S2 1xx must be completely wired first. Only then may the operating voltages for the DC bus and the electronics be switched on. In the case of inversed wiring of the operating voltage connections, excessive operating voltage or in the case of confusing the connections for operating voltage and motor the servo positioning controller will be damaged.

## 7.5 LV-servoTEC S2 1xx complete system

The complete servo positioning controller LV-servoTEC S2 1xx system is shown in Figure 18. The following components are required for using the servo positioning controller:

- Main switch mains supply
- Fault current protection switch (RCD), AC/DC sensitive 300mA
- Automatic circuit breaker
- Servo positioning controller LV-servoTEC S2 1xx
- Motor with motor cable
- Mains cable

The parameterisation requires a PC with serial connection cable.

A slow-blow (B16) single-phase automatic circuit breaker of 16 A has to be installed in the mains supply line.



For UL-certifying the following data for the main fuse are to be considered:  
Listed Circuit Breaker according UL 489, rated 277 Vac, 16 A, SCR 10 kA

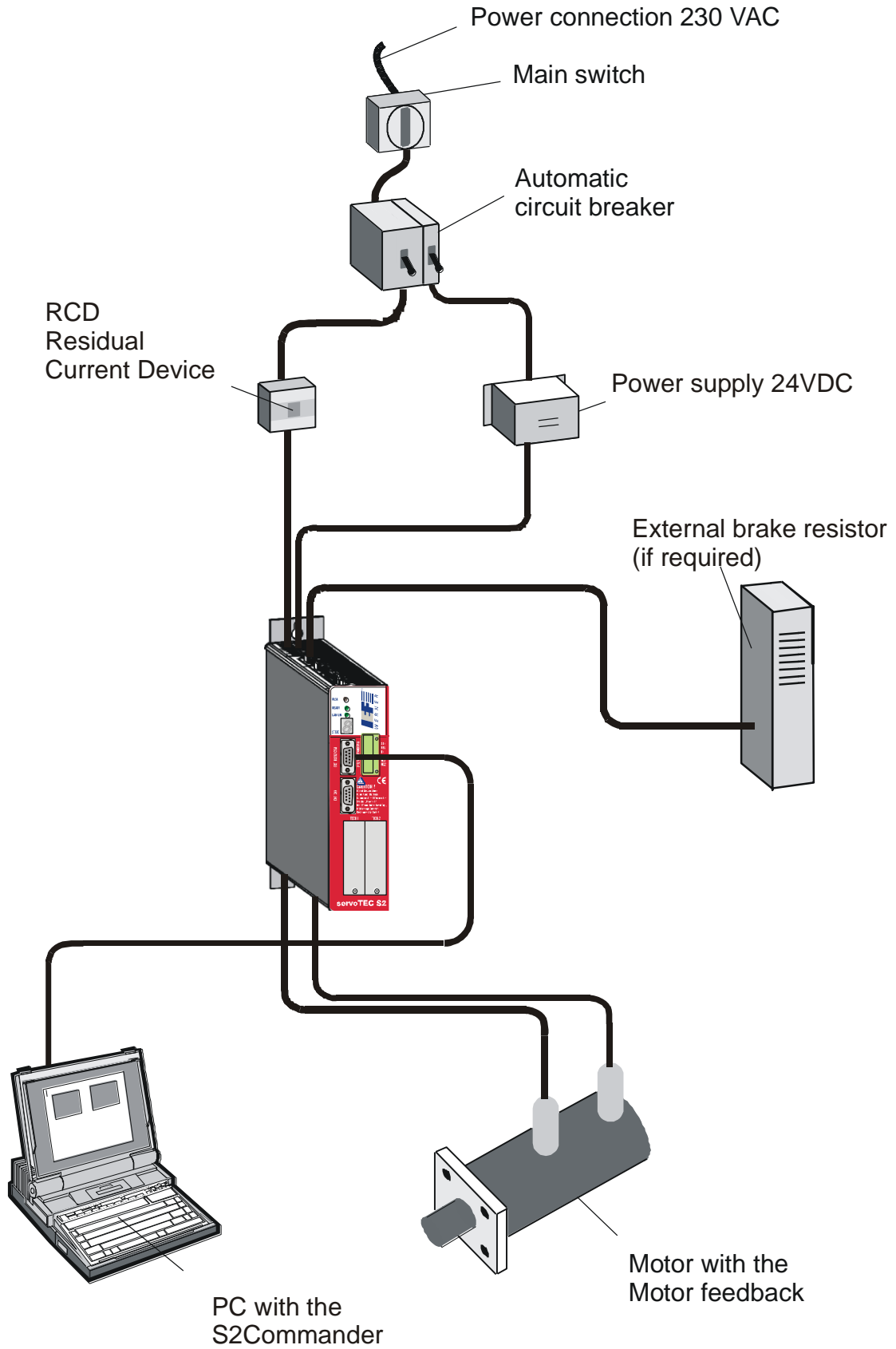

**Figure 18: Complete setup of the LV-servoTEC S2 1xx with motor and PC**

## 7.6 Connection: Power supply [X9]

The servo positioning controller LV-servoTEC S2 1xx receives its 24 VDC power supply for the control electronics also via connector [X9].

The mains voltage supply is single-phase. As an alternative to AC feed or for the purpose of DC bus coupling a direct DC supply for the DC bus is possible.

### 7.6.1 Device side [X9]

- PHOENIX Mini-Combicon MC 1,5/9-G-5,08

### 7.6.2 Counterplug [X9]

- PHOENIX Mini-Combicon MC 1,5/9-ST-5,08
- PHOENIX Mini-Combicon connector housing 12-pole, KGG-MC 1,5/12
- Coding to PIN9 (GND24V)

### 7.6.3 Pin configuration [X9]

Table 26: Pin configuration [X9]

Pin No.	Denomination	Value	Specification
1	L	230V AC	Mains phase
2	N	230V AC	Mains neutral conductor
3	ZK+	< 440V DC	Pos. DC bus voltage
4	ZK-	GND_ZK	Neg. DC bus voltage
5	BR-INT	< 440V DC	Connection of internal brake resistor (bridge to BR-CH when using the internal resistor)
6	BR-CH	< 440V DC	Brake chopper connection for internal brake resistor against BR-INT and external brake resistor against ZK+
7	PE	PE	Connection ground conductor from mains
8	+24V	+24V / 1.5A	Supply for control part (0.5A) and holding brake (1A)
9	GND24V	GND24	Reference potential supply

### 7.6.4 Cable type and design [X9]

The mentioned cable denominations refer to cables by Lapp. They have proven effective and are successfully used in many applications. However, similar cables from other manufacturers, e.g. Lütze or Helukabel, may also be used.

For the 230V supply:

- LAPP KABEL ÖLFLEX-CLASSIC 110; 3 x 1.5 mm<sup>2</sup>

### 7.6.5 Connection notes [X9]



**Figure 19: Supply [X9]**

The servo positioning controller LV-servoTEC S2 1xx has an internal brake chopper with brake resistor. For more brake power it is possible to connect an external brake resistor to the connector [X9].

Table 27: Connector [X9]: External brake resistor

Pin No.	Denomination	Value	Specification
5	BR-INT	< 440V DC	Connection of internal brake resistor (bridge to BR-CH when using the internal resistor)
6	BR-CH	< 440V DC	Brake chopper connection for internal brake resistor against BR-INT and external brake resistor against ZK+



If no external brake resistor is used, a bridge must be connected between PIN5 and PIN6, in order for the DC bus discharge and DC bus rapid discharge to function properly!

## 7.7 Connection: Motor [X6]

### 7.7.1 Device side [X6]

- PHOENIX Mini-Combicon MC 1,5/9-G-5,08

### 7.7.2 Counterplug [X6]

- PHOENIX Mini-Combicon MC 1,5/9-ST-5,08
- PHOENIX Mini-Combicon connector housing 12-pole, KGG-MC 1,5/12
- Coding to PIN1 (BR-)

### 7.7.3 Pin configuration [X6]

Table 28: Pin configuration [X6]

Pin No.	Denomination	Value	Specification
1	BR-	0V brake	Holding brake (motor), signal level dependent on switch status, high side / low side switch
2	BR+	24V brake	
3	PE	PE	Cable shield from motor
4	-MTdig	GND	Motor temperature sensor, normally closed contact, PTC, KTY...
5	+MTdig	+5V / 5mA	
6	PE	PE	Ground conductor from motor
7	W	0...270V <sub>RMS</sub>	Connection of three motor phases
8	V	0...2,5 A <sub>RMS</sub> (LV-servoTEC S2 102)	
9	U	0...5 A <sub>RMS</sub> (LV-servoTEC S2 105) 0...1000Hz	



The cable shield of the motor cable must also be connected to the controller housing (PE screw terminal).

### 7.7.4 Cable type and design [X6]

The mentioned cable denominations refer to cables by Lapp. They have proven effective and are successfully used in many applications. However, similar cables from other manufacturers, e.g. Lütze or Helukabel, may also be used.

- LAPP KABEL ÖLFLEX-SERVO 700 CY; 4 G 1.5 + 2 x (2 x 0.75) StD-CY; Ø 12.7 mm, with tinned total Cu shielding

For highly flexible applications:

- LAPP KABEL ÖLFLEX-SERVO-FD 755 CP; 4 G 1.5 + 2 x (2 x 0.75 StD) CP; Ø 15.4 mm, with tinned total Cu shielding for highly flexible use in drag chains

### 7.7.5 Connection notes [X6]

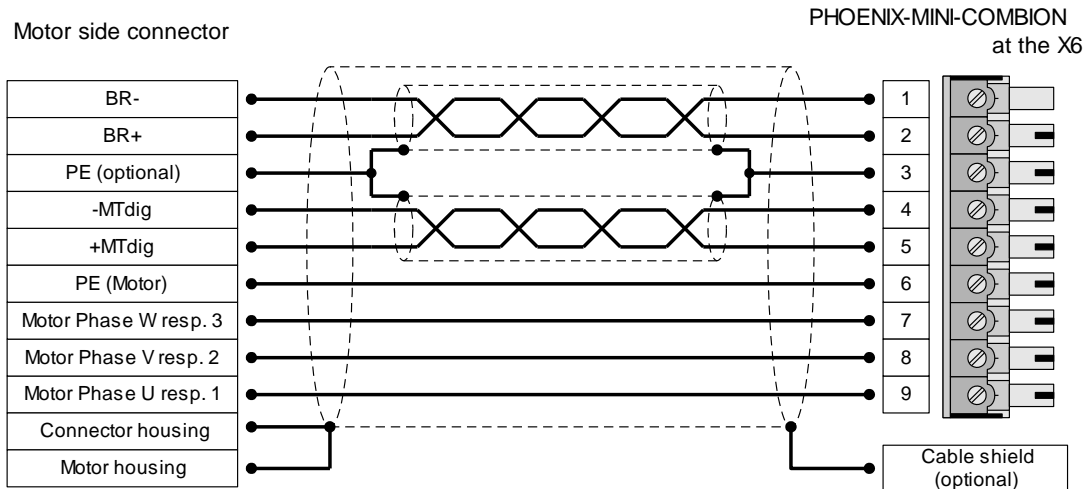
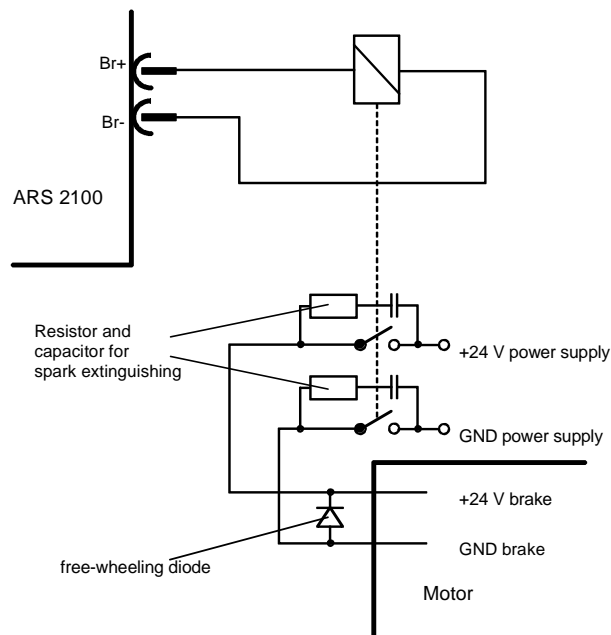

**Figure 20: Motor connection [X6]**

- Connect the inner shields to PIN 3; maximum length 40 mm.
- Length of unshielded cores maximum 35 mm.
- Connect total shield on controller side flat to PE terminal; maximum length 40 mm.
- Connect total shield on motor side flat to connector or motor housing; maximum length 40 mm.

Via terminals ZK+ and ZK- the DC bus of several servo positioning controllers LV-servoTEC S2 1xx can be interconnected. The coupling of the DC bus is interesting for applications with high brake energies or if movements have to be carried out even in the case of power failure. For further information please refer to Application Note 67.

A holding brake can be connected to terminals BR+ and BR- of the motor. The arresting brake is fed by the servo positioning controller's power supply. Note the maximum output current provided by the servo positioning controller LV-servoTEC S2 1xx. A relay may have to be placed between the device and the arresting brake as shown in Figure 17:



**Figure 21: Connecting a holding brake with high current draw (> 1A) to the device**



The switching of inductive direct current via relay produces strong currents and sparking. For interference suppression we recommend integrated RC suppressor elements, e.g. by Evox RIFA, denomination: PMR205AC6470M022 (RC element with  $22\Omega$  in series with  $0.47\mu\text{F}$ ).

## 7.8 Connection: I/O communication [X1]

The following Figure 22 shows the principle function of the digital and analog inputs and outputs. The servo positioning controller LV-servoTEC S2 1xx is shown on the right hand side, the controller connection on the left. The cable design is also visible.

The servo positioning controller LV-servoTEC S2 1xx features two potential ranges:

### Analog inputs and outputs:

All analog inputs and outputs refer to AGND. AGND is internally connected with GND, the reference potential for the control part with  $\mu\text{C}$  and AD converters in the controller. This potential range is galvanically separated from the 24V range and from the DC bus.

### 24V inputs and outputs:

These signals refer to the 24V supply voltage of the servo positioning controller LV-servoTEC S2 1xx which is fed via [X9], and separated from the reference potential of the control part by means of optocouplers.

Control system

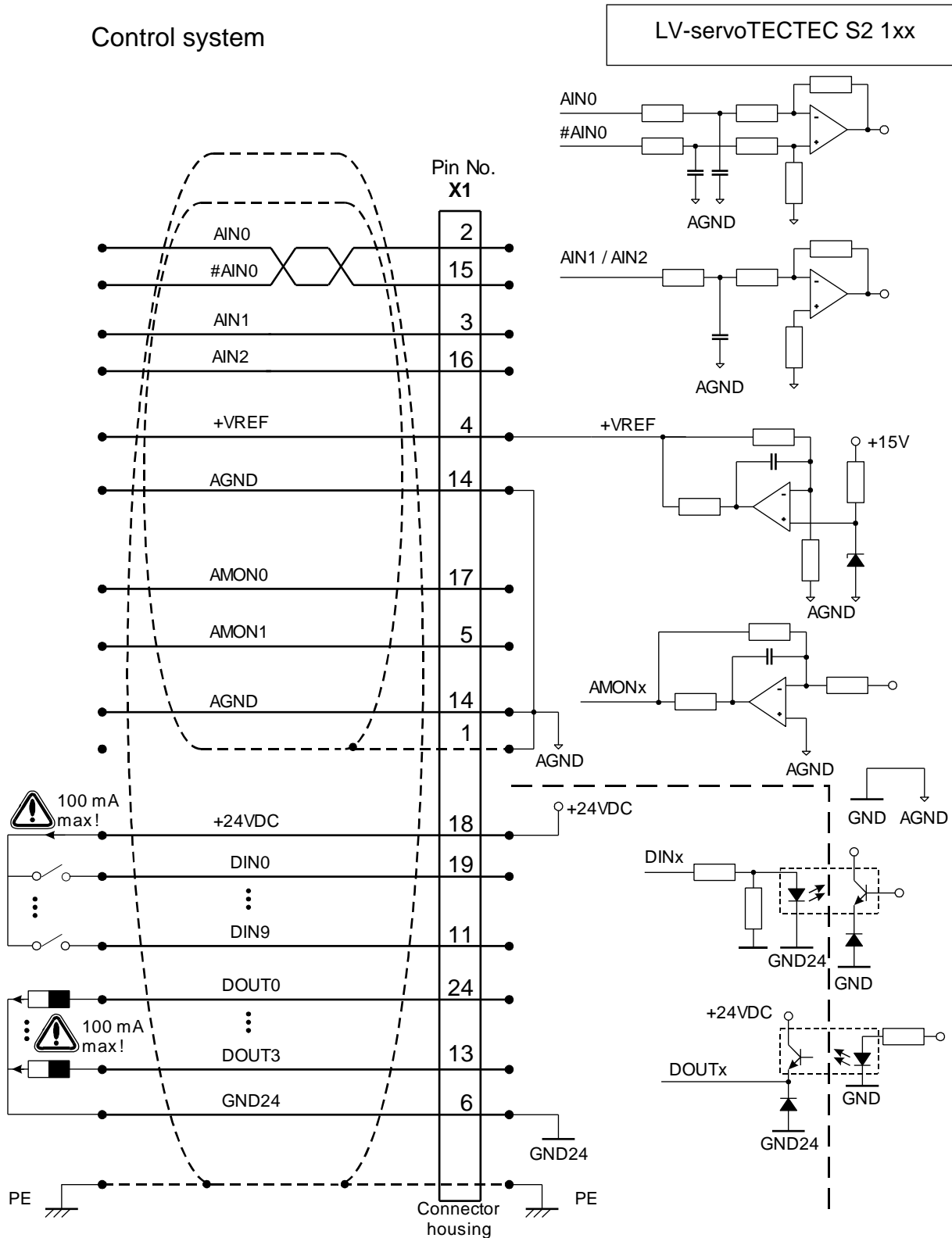

Figure 22: Basic circuit diagram connector [X1]

The servo positioning controller LV-servoTEC S2 1xx comprises one differential (AIN0) and two single-ended analog inputs, designed for input voltages within a range of  $\pm 10V$ . The inputs AIN0 and #AIN0 are lead to the control via twisted cables (twisted pair design).

If the control comprises single-ended outputs, the output is connected to AIN0 and #AIN0 is put on the reference potential of the control. If the control has differential outputs, they are to be connected 1:1 to the differential inputs of the servo positioning controller LV-servoTEC S2 1xx.

The reference potential AGND is connected to the reference potential of the control. This is necessary in order to prevent the differential input of the servo positioning controller LV-servoTEC S2 1xx from being overridden by high "common-mode interference".

There are two analog monitor outputs with output voltages in the range of  $\pm 10V$  and an output for a reference voltage of +10V. These outputs can be led to the superimposed control, the reference potential AGND must be carried along. If the control has differential inputs, the "+"-input of the control is connected to the output of the servo positioning controller LV-servoTEC S2 1xx and "-"-input of the control with AGND.

#### 7.8.1 Device side [X1]

- D-SUB connector, 25-pole, female

#### 7.8.2 Counterplug [X1]

- D-SUB connector, 25-pole, male
- Housing for 25-pole D-SUB connector with bolting screws 4/40 UNC

### 7.8.3 Pin configuration [X1]

Table 29: Connector configuration: I/O communication [X1]

Pin No.	Designation	Value	Specification
1	AGND	0V	Shield for analog signals, AGND
14	AGND	0V	Reference potential for analog signals
2	AIn0	$U_{on} = \pm 10V$ $R_1 = 20k\Omega$	Setpoint input 0, differential, max. 30V input voltage
15	#AIn0		
3	Ain1	$U_{on} = \pm 10V$ $R_1 = 20k\Omega$	Setpoint inputs 1 and 2, single ended, max. 30V input voltage
16	Ain2		
4	+VREF	+10V	Reference output for setpoint potentiometer
17	AMON0	$\pm 10V$	Analog monitor output 0
5	AMON1	$\pm 10V$	Analog monitor output 1
18	+24V	24V / 100mA	24V supply out
6	GND24	corresponding GND	Reference potential for digital I/Os
19	DIn0	POS Bit0	Target selection positioning Bit0
7	DIn1	POS Bit1	Target selection positioning Bit1
20	DIn2	POS Bit2	Target selection positioning Bit2
8	DIn3	POS Bit3	Target selection positioning Bit3
21	DIn4	FG_E	Power stage enable
9	DIn5	FG_R	Controller enable
22	DIn6	END0	Input end switch 0 (locks $n < 0$ )
10	DIn7	END1	Input end switch 1 (locks $n > 0$ )
23	DIn8	START	Input for positioning start
11	DIn9	SAMP	High-speed input
24	DOut0 / READY	24V / 100mA	Output operational
12	DOut1	24V / 100mA	Output freely programmable
25	DOut2	24V / 100mA	Output freely programmable
13	DOut3	24V / 100mA	Output freely programmable

#### 7.8.4 Cable type and design [X1]

The mentioned cable denominations refer to cables by Lapp. They have proven effective and are successfully used in many applications. However, similar cables from other manufacturers, e.g. Lütze or Helukabel, may also be used.

- LAPP KABEL UNITRONIC-LiYCY; 25 x 0,25 mm<sup>2</sup>

*Figure 22* shows the cable between the servo positioning controller LV-servoTEC S2 1xx and the control. The cable shown has two cable shields.

The outer cable shield is connected on both sides to PE. Inside the servo positioning controller the connector housing of the D-Sub connector is connected to PE. When using metal D-Sub connector housings the cable shield is simply squeezed underneath the strain relief.

Often, an unshielded cable is sufficient for the 24V signals. In heavily disturbed surroundings or in the case of long cables ( $l > 2\text{m}$ ) between the control and the servo positioning controller LV-servoTEC S2 1xx recommends the use of shielded cables.

In spite of the differential design of the analog inputs of the LV-servoTEC S2 1xx the cables should not be unshielded, since interferences, e.g. due to switching contactors or final stage interferences of the converters can reach high amplitudes. They couple into the analog signals and cause common-mode interference, which may lead to deviation of the analog measured values.

In the case of limited cable lengths ( $l < 2\text{m}$ , wiring inside control cabinet) the outer dual-sided PE shield is enough to guarantee undisturbed operation.

For optimal interference suppression on the analog signals the cores for the analog signals are to be shielded together and separate from others. This internal cable shield is at the LV-servoTEC S2 1xx on one side connected to AGND (Pin 1 or 14). It can be connected on both sides in order to establish a connection between the reference potentials of the control and the servo positioning controller LV-servoTEC S2 1xx. Pins 1 and 14 are directly connected to each other inside the controller.

#### 7.8.5 Connection notes [X1]

The digital inputs are designed for control voltages of 24V. Due to the high signal level a higher interference immunity of these inputs is already guaranteed. The servo positioning controller LV-servoTEC S2 1xx provides a 24V auxiliary voltage, which may be loaded with a maximum of 100 mA. This way the inputs can be activated directly via switches. Activation via the 24V outputs of a PLC is, of course, also possible.

The digital outputs are designed as so-called "high-side switches". That means that the 24V of the servo positioning controller LV-servoTEC S2 1xx are actively switched through to the output. Loads such as lamps, relays, etc. are thus switched from the output to GND24. The four outputs DOUT0 to DOUT3 can be loaded with a maximum of 100mA each. The outputs can also be lead directly to 24V inputs of a PLC.

## 7.9 Connection: Safe Standstill [X3]

The description of the safety function "safe stop" is in chapter 6 Functional safety technology.

### 7.9.1 Device side [X3]

- PHOENIX Mini-Combicon MC 1.5/6-STF-3.81

### 7.9.2 Counterplug [X3]

- PHOENIX Mini-Combicon MC 1.5/ 6-GF-3.81

### 7.9.3 Pin assignment [X3]

Table 30: Pin assignment [X3]

Pin no.	Designation	Value	Specification
1	24V	24VDC	24VDC supply, led out (Without safety measures in accordance with category 3: Bridge pin 1 and 2)
2	REL	0V / 24VDC	Setting and resetting of the relay for interrupting the driver supply of the output stage
3	0V	0V	Reference potential for PLC
4	---	---	Not connect
5	NC1	250VAC max. switching voltage	Floating response contact of driver supply; normally closed contact
6	NC2		

### 7.9.4 Connection notes [X3]

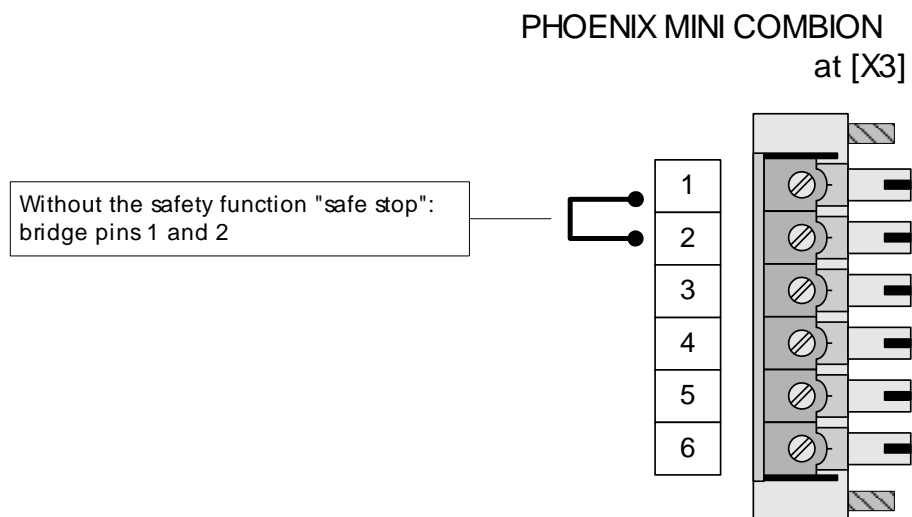

Figure 23: Connection notes [X3]: without safety function

## 7.10 Connection: Resolver [X2A]

### 7.10.1 Device side [X2A]

- 1 D-SUB connector, 9-pole, female

### 7.10.2 Counterplug [X2A]

- D-SUB connector, 9-pole, male
- Housing for 9-pole D-SUB connector with bolting screws 4/40 UNC

### 7.10.3 Pin configuration [X2A]

Table 31: Pin configuration [X2A]

Pin No.	Designation	Value	Specification
1	S2	3,5V <sub>RMS</sub> / 10kHz	SINE trace signal, differential
6	S4	R <sub>i</sub> > 5kΩ	
2	S1	3,5V <sub>RMS</sub> / 10kHz	COSINE trace signal, differential
7	S3	R <sub>i</sub> > 5kΩ	
3	AGND	0V	Shield for signal pairs (inner shield)
8	MT-	GND	Reference potential temperature sensor
4	R1	7V <sub>RMS</sub> / I <sub>A</sub> ≤ 50mA <sub>RMS</sub>	Carrier signal for resolver
9	R2	GND	
5	MT+	+5V / 5mA	Motor temperature sensor, normally closed contact, PTC, KTY...

### 7.10.4 Cable type and design [X2A]

The mentioned cable denominations refer to cables by Lapp. They have proven effective and are successfully used in many applications. However, similar cables from other manufacturers, e.g. Lütze or Helukabel, may also be used.

- LAPP KABEL ÖLFLEX-SERVO 720 CY; 3 x (2 x 0,14 CY) + 2 x (0,5 CY) CY; Ø 8.5 mm, with tinned total Cu shielding  
Error during angle detection up to ca. 1.5° at 50 m cable length
  - 2 x (0.5 CY) use carriers for the resolver!

For highly flexible applications:

- LAPP KABEL ÖLFLEX-SERVO-FD 770 CP; 3 x (2 x 0,14 D12Y) + 2 x (0,5 D12Y) CP; Ø 8.3 mm, with tinned total Cu shielding  
Error during angle detection up to ca. 1.5° at 50 m cable length
  - 2 x (0.5 D12Y) use carriers for the resolver!

### 7.10.5 Connection notes [X2A]

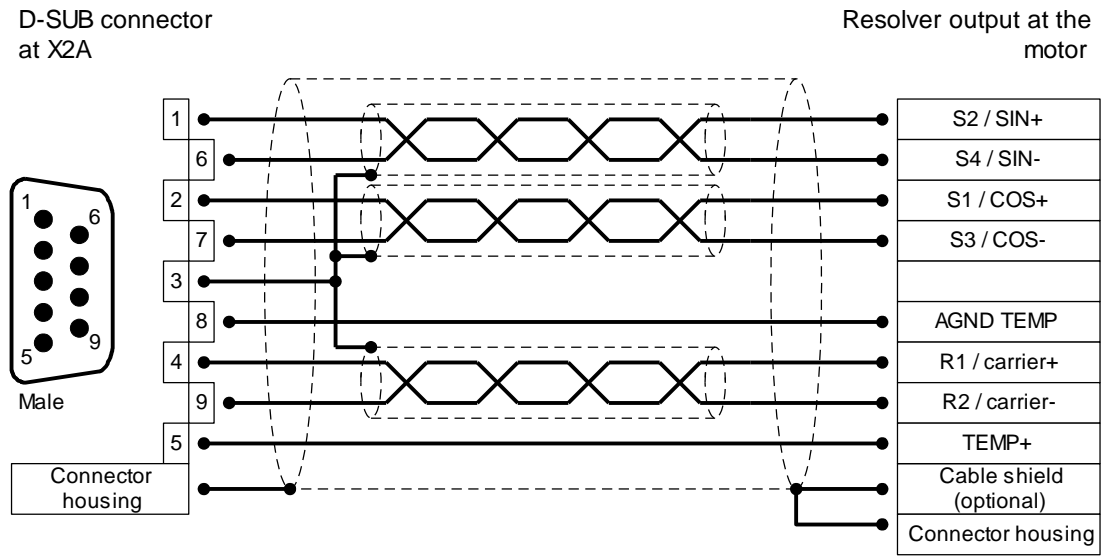

**Figure 24: Pin configuration: Resolver connection [X2A]**

- The outer shield is always connected to PE (connector housing) on the controller side.
- The three inner shields are connected on one side of the servo positioning controller LV-servoTEC S2 1xx to PIN3 of [X2A].

## 7.11 Connection: Encoder [X2B]

### 7.11.1 Device side [X2B]

- D-SUB connector, 15-pole, female

### 7.11.2 Counterplug [X2B]

- D-SUB connector, 15-pole, male
- Housing for 15-pole D-SUB connector with bolting screws 4/40 UNC

### 7.11.3 Pin configuration [X2B]

Table 32: Pin configuration: Analog incremental encoder – optional [X2B]

Pin No.	Designation	Value	Specification
1	MT+	+5V / 5mA	Motor temperature sensor, normally closed contact, PTC, KTY...
	9	U_SENS+	Sensor cables for encoder supply
2	U_SENS-	$R_I \approx 1k\Omega$	
	10	US	Supply voltages for high-resolution incremental encoder
		5V / 12V / $\pm 10\%$ $I_{max} = 300mA$	
3	GND0	0V	Reference potential encoder supply and motor temperature sensor
	11	R	Reset pulse trace signal (differential) from high-resolution incremental encoder
4	#R	0,2V <sub>PP</sub> .. 0,8V <sub>PP</sub> $R_I \approx 120\Omega$	
	12	COS_Z1*	COSINE commutation signal (differential) from high-resolution incremental encoder
5	#COS_Z1*	1V <sub>PP</sub> $\pm 10\%$ $R_I \approx 120\Omega$	
	13	SIN_Z1*	SINE commutation signal (differential) from high-resolution incremental encoder
6	#SIN_Z1	1V <sub>PP</sub> $\pm 10\%$ $R_I \approx 120\Omega$	
	14	COS_Z0*	COSINE trace signal (differential) from high-resolution incremental encoder
7	#COS_Z0*	1V <sub>PP</sub> $\pm 10\%$ $R_I \approx 120\Omega$	
	15	SIN_Z0*	SINE trace signal (differential) from high-resolution incremental encoder
8	#SIN_Z0*	1V <sub>PP</sub> $\pm 10\%$ $R_I \approx 120\Omega$	

\*) Heidenhain encoder: A=SIN\_Z0; B=COS\_Z0; C=SIN\_Z1; D=COS\_Z1

Table 33: Pin configuration: Incremental encoder with serial communication interface  
(e.g. EnDat, HIPERFACE) – optional [X2B]

Pin No.	Designation	Value	Specification
1	MT+	+5V / 5mA	Motor temperature sensor, normally closed contact, PTC, KTY...
9	U_SENS+	5V...12V / $R_I \approx 1k\Omega$	Sensor cables for encoder supply
2	U_SENS-		
10	US	5V / 12V/ $\pm 10\%$ $I_{max} = 300mA$	Supply voltages for high-resolution incremental encoder
3	GND	0V	Reference potential encoder supply and motor temperature sensor
11			
4			
12	DATA	5V <sub>PP</sub> $R_I \approx 120\Omega$	Bidirectional RS485 data line (differential) (EnDat/HIPERFACE)
5	#DATA		
13	SCLK	5V <sub>PP</sub> $R_I \approx 120\Omega$	Clock output RS485 (differential) (EnDat)
6	#SCLK		
14	COS_Z0*	1V <sub>PP</sub> $\pm 10\%$ $R_I \approx 120\Omega$	COSINE trace signal (differential) from high-resolution incremental encoder
7	#COS_Z0*		
15	SIN_Z0*	1V <sub>PP</sub> $\pm 10\%$ $R_I \approx 120\Omega$	SINE trace signal (differential) from high-resolution incremental encoder
8	#SIN_Z0*		

\*) Heidenhain encoder: A=SIN\_Z0; B=COS\_Z0

Table 34: Pin configuration: Digital incremental encoder – option [X2B]

Pin No.	Designation	Value	Specification
1	MT+	+5V / 5mA	Motor temperature sensor, normally closed contact, PTC, KTY...
	9	5V...12V / $R_I \approx 1k\Omega$	Sensor cables for encoder supply
2	U_SENS-		
	10	5V..12V/ $\pm 10\%$ $I_{max} = 300mA$	Supply voltages for high-resolution incremental encoder
3	GND	0V	Reference potential encoder supply and motor temperature sensor
	11	2V <sub>PP</sub> .. 5V <sub>PP</sub> $R_I \approx 120\Omega$	Reset pulse trace signal (differential) from digital incremental encoder
4	#N		
	12	0V / 5V $R_I \approx 2k\Omega$ an VCC	Phase U hall sensor for commutation
5	H_V		Phase V hall sensor for commutation
	13		Phase W hall sensor for commutation
6			
	14	2V <sub>PP</sub> .. 5V <sub>PP</sub> $R_I \approx 120\Omega$	A trace signal RS422 (differential) from digital incremental encoder
7	#A		
	15	2V <sub>PP</sub> .. 5V <sub>PP</sub> $R_I \approx 120\Omega$	B trace signal RS422 (differential) from digital incremental encoder
8	#B		

#### 7.11.4 Cable type and design [X2B]

We recommend using the encoder connection cables released for their product by the corresponding manufacturer (Heidenhain, Stegmann, etc.). If the manufacturer does not recommend a particular cable, we recommend the assembly of the encoder connections cables as described below.



For the angle encoder supply US and GND, we recommend a minimum cross-section of 0.25 mm<sup>2</sup> for an angle encoder cable length up to 25 m, and a minimum cross-section of 0.5 mm<sup>2</sup> for an angle encoder cable length up to 50 m.

### 7.11.5 Connection notes [X2B]

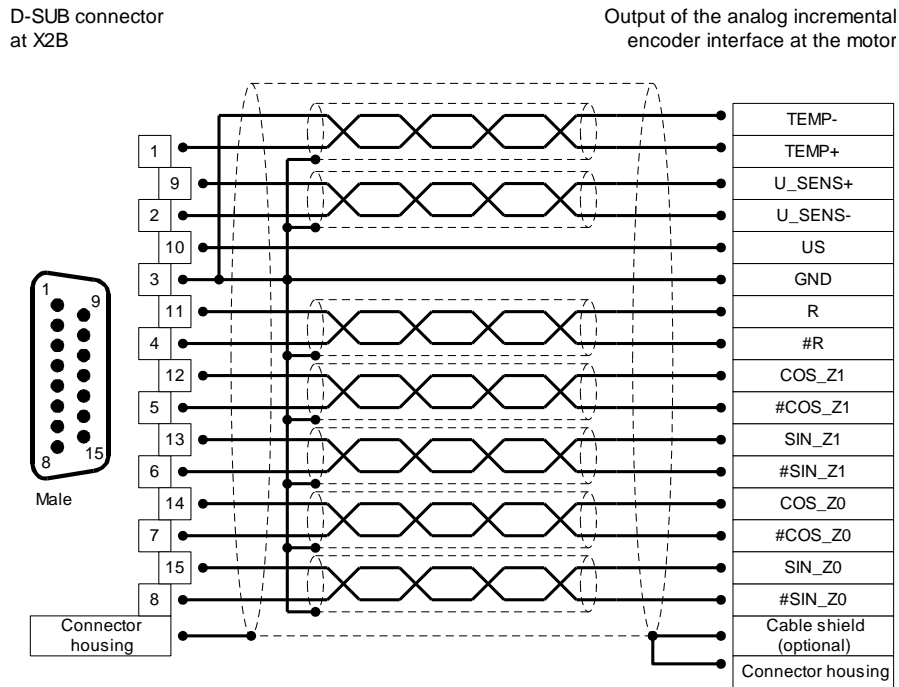

Figure 25: Pin configuration: Analog incremental encoder – optional [X2B]

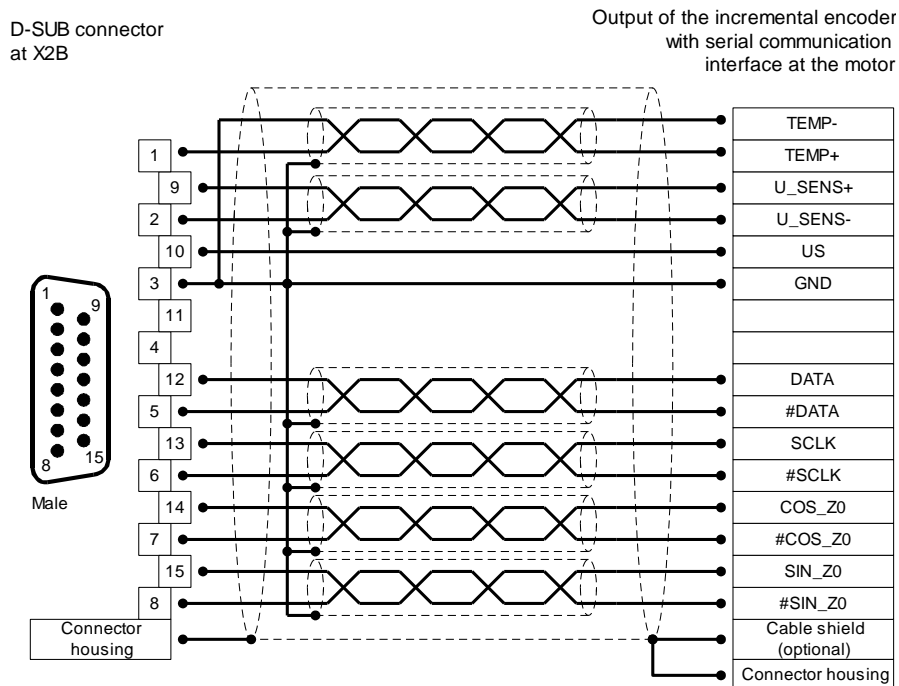

Figure 26: Pin configuration: Incremental encoder with serial communication interface (e.g. EnDat, HIPERFACE) – optional [X2B]

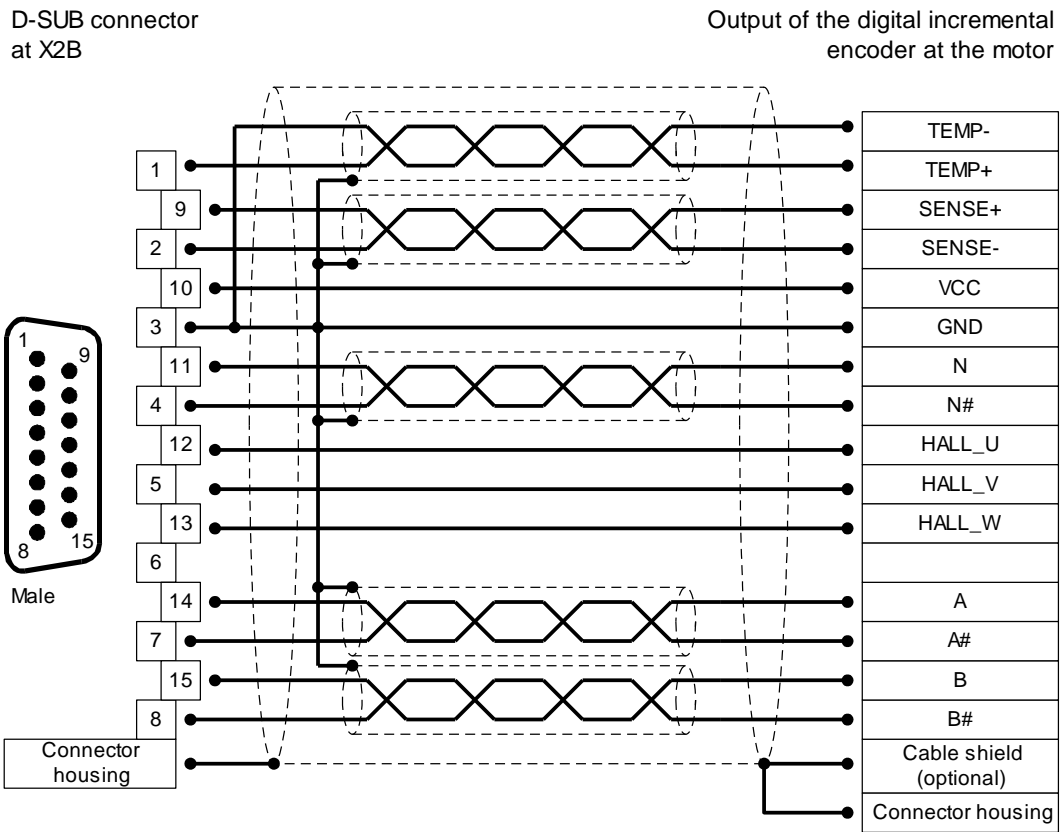

Figure 27: Pin configuration: Digital incremental encoder – option [X2B]

## 7.12 Connection: Incremental encoder input [X10]

### 7.12.1 Device side [X10]

- D-SUB connector, 9-pole, female

### 7.12.2 Counterplug [X10]

- D-SUB connector, 9-pole, male
- Housing for 9-pole D-SUB connector with bolting screws 4/40 UNC

### 7.12.3 Pin configuration [X10]

Table 35: Pin configuration [X10]: Incremental encoder input

Pin No.	Designation	Value	Specification
1	A / CLK	5V / $R_1 \approx 120\Omega$	Incremental encoder signal A / Stepper motor signal CLK pos. polarity as per RS422
6	A# /CLK#	5V / $R_1 \approx 120\Omega$	Incremental encoder signal A / Stepper motor signal CLK neg. polarity as per RS422
2	B / DIR	5V / $R_1 \approx 120\Omega$	Incremental encoder signal B / Stepper motor signal DIR pos. polarity as per RS422
7	B# /DIR#	5V / $R_1 \approx 120\Omega$	Incremental encoder signal B / Stepper motor signal DIR neg. polarity as per RS422
3	N	5V / $R_1 \approx 120\Omega$	Incremental encoder index pulse N pos. polarity as per RS422
8	N#	5V / $R_1 \approx 120\Omega$	Incremental encoder index pulse N neg. polarity as per RS422
4	GND	-	Supply GND for encoder
9	GND	-	Shield for the connection cable
5	VCC	+5V $\pm$ 5% 100mA	Auxiliary supply, load with 100mA maximum, but short circuit-proof!

### 7.12.4 Cable type and design [X10]

We recommend encoder connection cables twisted in pairs and individually protected.

### 7.12.5 Connection notes [X10]

Input [X10] can be used to process incremental encoder signals as well as pulse direction signals, as generated by control boards for stepper motors.

The input amplifier at the signal input is designed for the processing of differential signals as per interface standard RS422. Processing of other signals and levels (e.g. 5V single-ended or 24V<sub>HTL</sub> from a PLC) may be possible. Please contact your sales representative.

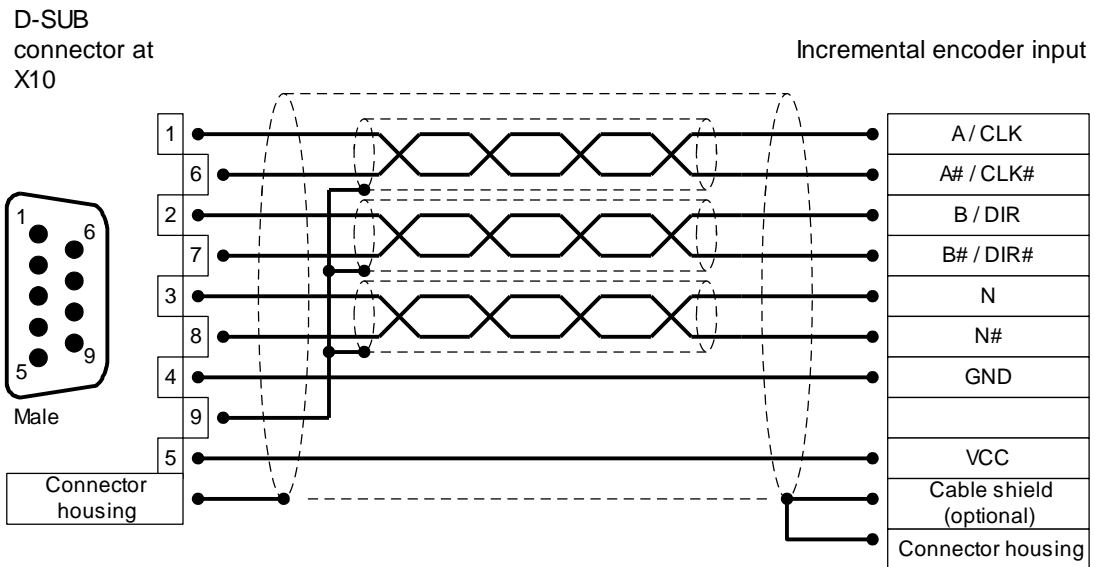

Figure 28: Pin configuration: Input of the incremental encoder [X10]

## 7.13 Connection: Incremental encoder output [X11]

### 7.13.1 Device side [X11]

- D-SUB connector, 9-pole, female

### 7.13.2 Counterplug [X11]

- D-SUB connector, 9-pole, male
- Housing for 9-pole D-SUB connector with bolting screws 4/40 UNC

### 7.13.3 Pin configuration [X11]

Table 36: Pin configuration [X11]: Incremental encoder output

Pin No.	Designation	Value	Specification
1	A	5V / $R_A \approx 66\Omega$ *)	Incremental encoder signal A
6	A#	5V / $R_A \approx 66\Omega$ *)	Incremental encoder signal A#
2	B	5V / $R_A \approx 66\Omega$ *)	Incremental encoder signal B
7	B#	5V / $R_A \approx 66\Omega$ *)	Incremental encoder signal B#
3	N	5V / $R_A \approx 66\Omega$ *)	Incremental encoder index pulse N
8	N#	5V / $R_A \approx 66\Omega$ *)	Incremental encoder index pulse N#
4	GND	-	Reference GND for encoder
9	GND	-	Shield for connection cable
5	VCC	+5V $\pm$ 5% 100mA	Auxiliary supply, to be loaded with maximal 100mA, but short-circuit-proof!

\*) The value for  $R_A$  is the differential output resistance

### 7.13.4 Cable type and design [X11]

We recommend encoder connection cables twisted in pairs and individually protected.

### 7.13.5 Connection notes [X11]

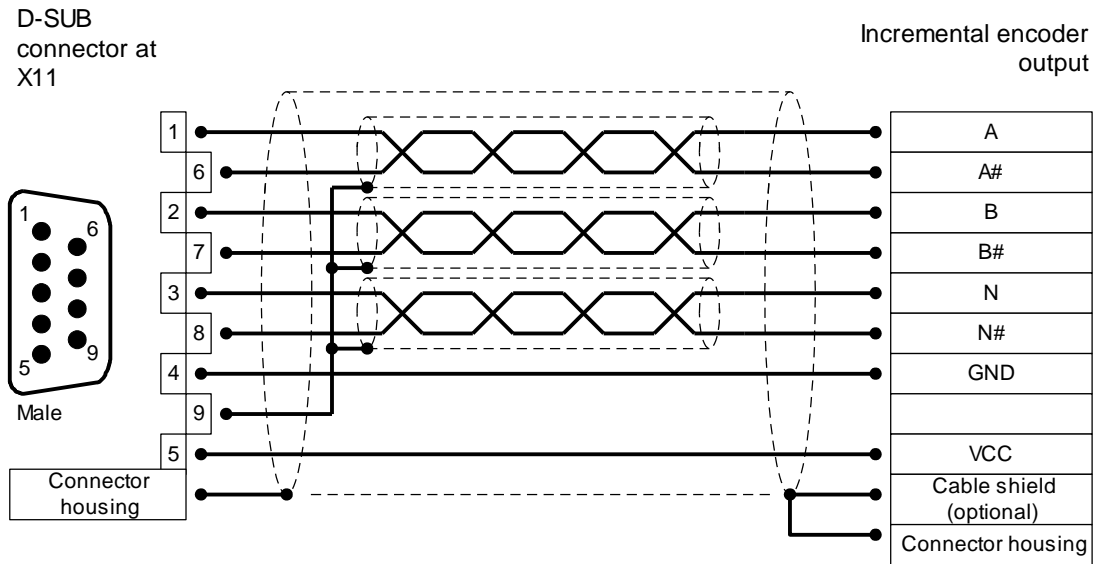

**Figure 29: Pin configuration: Incremental encoder output [X11]**

The output driver at the signal output provides differential signals (5V) as per interface standard RS422.

Up to 32 other controllers may be driven by one device.

## 7.14 Connection: CAN-Bus [X4]

### 7.14.1 Device side [X4]

- D-SUB connector, 9-pole, female

### 7.14.2 Counterplug [X4]

- D-SUB connector, 9-pole, male
- Housing for 9-pole D-SUB connector with bolting screws 4/40 UNC

### 7.14.3 Pin configuration [X4]

Table 37: Pin configuration CAN-Bus [X4]

Pin No.	Designation	Value	Specification
1	-	-	Not occupied
6	GND	0V	CAN-GND, galvanically connected to GND in controller
2	CANL	*)	CAN-Low signal line
7	CANH	*)	CAN-High signal line
3	GND	0V	See Pin no. 6
8	-	-	Not occupied
4	-	-	Not occupied
9	-	-	Not occupied
5	Cable shield	PE	Connection for cable shield

\*) External terminating resistor 120Ω required on both ends of the bus. We recommend the use of metal film resistors with 1% tolerance in size 0207, e.g. company BCC item no. 232215621201.

### 7.14.4 Cable type and design [X4]

The mentioned cable denominations refer to cables by Lapp. They have proven effective and are successfully used in many applications. However, similar cables from other manufacturers, e.g. Lütze or Helukabel, may also be used.



Technical specifications CAN bus cable: 2 pairs of 2 twisted cores,  $d \geq 0.22 \text{ mm}^2$ , shielded, loop resistance  $< 0.2 \Omega/\text{m}$ , characteristic impedance 100-120 Ω

- LAPP KABEL UNITRONIC BUS CAN; 2 x 2 x 0.22; Ø 7.6 mm, with total Cu shielding

For highly flexible applications:

- LAPP KABEL UNITRONIC BUS-FD P CAN UL/CSA; 2 x 2 x 0.25; Ø 8.4 mm, with total Cu shielding

### 7.14.5 Connection notes [X4]



When cabling the connector via the CAN bus, make sure to observe the following information and notes, to ensure a stable and interference-free system. Improper cabling may cause the CAN bus to malfunction which in turn can cause the controller to shut down with an error for safety reasons.

The CAN bus provides a simple and fail-safe way of connecting all components of a system, assuming, however, compliance with the following notes on cabling.

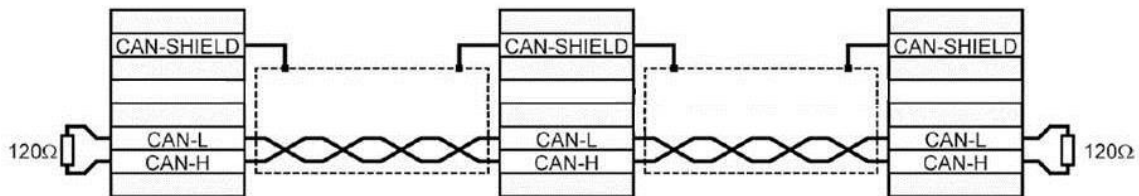

**Figure 30: Cabling example for CAN-Bus**

- The individual nodes of a network are always connected in line, so that the CAN cable is looped through from controller to controller (see Figure 30).
- On both ends of the CAN bus cable must be exactly one terminating resistor of  $120\Omega \pm 5\%$ . Such resistors are often already installed on CAN boards or in PLCs, which must be taken into consideration.
- **Shielded** cables with exactly two **twisted** pairs must be used for cabling.
- Use a twisted pair for the connection of CAN-H and CAN-L.
- The cores of the other pair are used **jointly** for CAN-GND.
- The shield of the cable is led to the CAN shield connections for all nodes.
- For suitable and IEF-Werner recommended cables please refer to chapter 7.14.4 *Cable type and design [X4]*
- We advise against the use of plug adaptors for CAN bus cabling. Should be necessary nonetheless, make sure to use metal connector housings to connect the cable shield.
- In order to keep interferences as low as possible make sure that
  - Motor cables are not installed parallel to signal lines.
  - Motor cables comply with IEF-Werner specifications.
  - Motor cables are properly shielded and grounded.
- For further information on interference-free CAN bus cabling, please refer to the Controller Area Network protocol specification, Version 2.0 by Robert Bosch GmbH, 1991.

## 7.15 Connection: RS232/COM [X5]

### 7.15.1 Device side [X5]

- D-SUB connector, 9-pole, female

### 7.15.2 Counterplug [X5]

- D-SUB connector, 9-pole, male
- Housing for 9-pole D-SUB connector with bolting screws 4/40 UNC

### 7.15.3 Pin configuration [X5]

Table 38: Pin configuration RS232 interface [X5]

Pin No.	Denomination	Value	Specification
1	-	-	Not occupied
6	-	-	Not occupied
2	RxD	10 V / $R_I > 2k\Omega$	Receive line, RS232 specification
7	-	-	Not occupied
3	TxD	10 V / $R_A < 2k\Omega$	Transmitting line, RS232 specification
8	-	-	Not occupied
4	+RS485	-	reserved for optional RS485 use
9	-RS485	-	reserved for optional RS485 use
5	GND	0V	Interfaces GND, galvanically connected to GND DGND

### 7.15.4 Cable type and design [X5]

Interface cable for serial interface (null modem), 3-core.

### 7.15.5 Connection notes [X5]

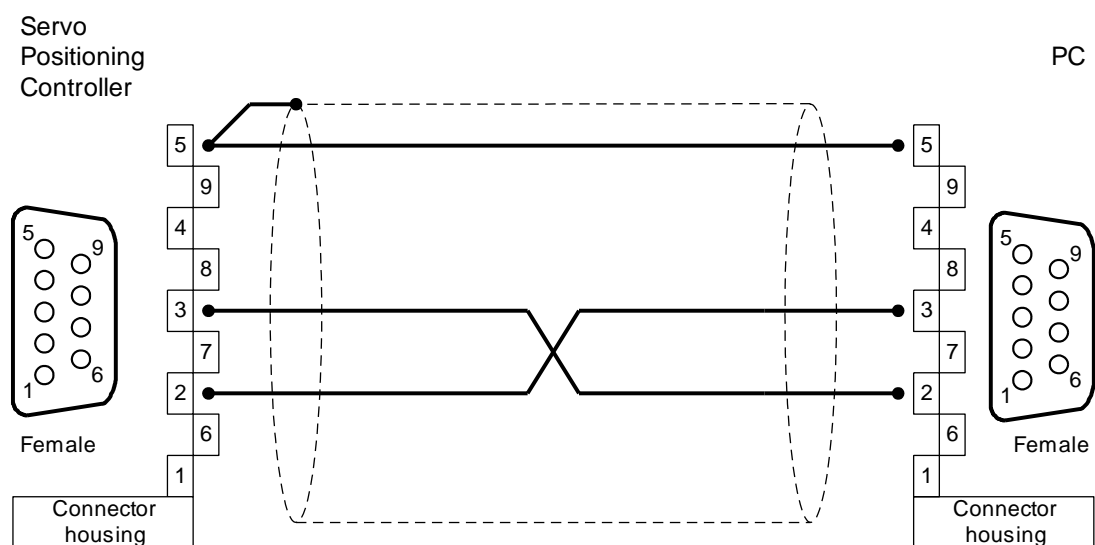

Figure 31: Pin configuration RS232 null modem cable [X5]

## 7.16 Notes on safe and EMC-compliant installation

### 7.16.1 Definition and terms

Electromagnetic compatibility (EMC) or electromagnetic interference (EMI) includes the following requirements:

- Sufficient **immunity** of an electrical installation or an electrical device against outside electrical, magnetic or electromagnetic interferences via cables or the ambient.
- Sufficiently small **unwanted emission** of electrical, magnetic or electromagnetic interference from an electrical installation or an electrical device to other devices in the vicinity via cables or the ambient.

### 7.16.2 General information on EMC

The interference emission and interference immunity of a device always depend on the entire drive concept consisting of the following components:

- Voltage supply
- Servo positioning controller
- Motor
- Electromechanics
- Execution and type of wiring
- Superimposed control

In order to increase interference immunity and to decrease interference emissions the servo positioning controller LV-servoTEC S2 1xx already comprises output chokes and mains filters, so that it can be operated without additional shielding and filtering devices.



The servo positioning controllers LV-servoTEC S2 1xx are certified as per the product standard EN 61800-3 for electrical drive systems.

**In most cases no external filtering is required (see below).**

The conformity certificate for EMC directive 89/336/EEC is available from the manufacturer.



#### **Warning!**

This product can cause high-frequency interference in residential areas, which could require measures for radio interference suppression.

### 7.16.3 EMC areas: first and second environment

Proper installation and wiring of all connecting cables provided, the LV-servoTEC S2 1xx servo positioning controllers fulfils the requirements of product standard EN 61800-3. This standard no longer refers to "classes", but to so-called environments. The first environment includes mains supply networks supplying residential buildings. The second environment includes mains supply networks exclusively supplying industrial buildings.

The following applies to LV-servoTEC S2 1xx servo positioning controllers without external filter measures:

Table 39: EMC requirements: First and second environment

EMC type	Environment	Compliance with EMC requirements
Interference emission	First environment (domestic environment)	Motor cable length up to 25m if $C' \leq 200 \text{ pF}$
	Second environment (industrial environment)	Motor cable length up to 25m if $C' \leq 200 \text{ pF}$
Interference immunity	First environment (domestic environment)	Independent of motor cable length
	Second environment (industrial environment)	

### 7.16.4 EMC-compliant cabling

The following must be considered for an EMC-compliant setup of the drive system (see also chapter 0 Electrical installation, page 63):

- In order to keep the leakage currents and the losses in the motor connection cable as small as possible, the servo positioning controller LV-servoTEC S2 1xx should be located as close to the motor as possible (see also the following *chapter 7.16.5 Operation with long motor cables*, page 92).
- Motor cable and angle encoder cable must be shielded.
- The shield of the motor cable is connected to the housing of the servo positioning controller LV-servoTEC S2 1xx (shield connection terminal). The cable shield also has to be connected to the associated servo positioning controller so that the leakage currents can flow back into the controller causing the leakage.
- The mains-end PE connection is connected to the PE connection point of the supply connection [X9].
- The inner PE conductor of the motor cable is connected to the PE connection point of the motor connection [X6].
- The signal lines must be as far away from the power cables as possible. They should not be placed parallel. If intersections cannot be avoided, they should be perpendicular (i.e. at a 90° angle), if possible.
- Unshielded signal and control lines should not be used. If their use is inevitable they should at least be twisted.
- Even shielded cables will inevitably have short unshielded ends (unless shielded connector housings are used). In general, the following applies:
  - Connect the inner shields to the corresponding pins of the connectors; Maximum length 40 mm.
  - Length of the unshielded cores 35 mm maximum.
  - Connect the total shield on the controller side plane to the PE terminal; Maximum length 40 mm.
  - Connect the total shield on the motor side plane to the connector housing or motor housing; Maximum length 40 mm.



**DANGER!**

For safety reasons, all PE ground conductors must be connected prior to initial operation.  
The EN 50178 regulations for protective earthing must be complied with during installation!

### 7.16.5 Operation with long motor cables

In applications involving long motor cables and/or unsuitable motor cables with an inadvertently high cable capacity, the filters may be thermally overloaded. To avoid such problems we highly recommend the following procedure for applications that require long motor cables:

- With cable lengths of more than 25 m use only cables with a capacitance per unit length between the motor phase and the shield of less than 200pF/m, if possible less than 150pF/m! (Please contact the motor cable supplier, if necessary)

### 7.16.6 ESD protection



Unassigned D-Sub connectors may cause damage to the device or other parts of the systems due to ESD (electrostatic discharge)



To prevent such discharge, protective caps are available (e.g. Spoerle).

The servo positioning controller LV-servoTEC S2 1xx has been designed to provide high interference immunity. For that reason, some individual functional blocks are electrically isolated. Inside the device the signals are transmitted via optocouplers.

The following isolated areas are distinguished:

- Power stage with DC bus and mains input
- Control electronics with processing of analog signals
- 24V supply and digital inputs and outputs

## 8 Initial operation

### 8.1 General notes on connection



Since the laying of the connection cables is very important in terms of EMC, make sure to comply with the previous *chapter 7.16.4 EMC-compliant cabling (page 91)*!



#### **DANGER!**

Noncompliance with *chapter 2 Safety notes for electrical drives and controllers (page 13)* may result in property damage, person injury, electric shock or in extreme cases in death.

### 8.2 Tools / material

- Screwdriver for slotted head screws size 1
- Serial interface cable
- Angle encoder cable
- Motor cable
- Power supply cable
- Controller enabling cable

### 8.3 Connecting the motor

- Plug the connector of the motor cable into the corresponding socket of the motor and screw tight.
- Plug PHOENIX connector into socket **[X6]** of the device.
- Connect the PE line of the motor to the **PE** socket.
- Plug the connector of the encoder cable into the encoder output socket of the motor and screw tight.
- Plug the D-Sub connector into the socket **[X2A] Resolver** or **[X2B] Encoder** of the device and fasten the bolting screws.
- Check all connections again.

### 8.4 Connecting the servo positioning controller LV-servoTEC S2 1xx to the power supply

- Make sure that the power supply has been switched off.
- Plug the PHOENIX connector into socket **[X9]** of the device.
- Connect the PE line of the mains to the **PE** socket.
- Connect the 24V connections to a suitable power supply unit.
- Make mains supply connections.
- Check all connections again.

## 8.5 Connecting the PC

- Plug the D-Sub connector of the serial interface cable into the socket for the serial interface of the PC and fasten the bolting screws.
- Plug the D-Sub connector of the serial interface cable into the socket **[X5] RS232/COM** of the servo positioning controller LV-servoTEC S2 1xx and fasten the bolting screws.
- Check all connections again.

## 8.6 Checking operability

1. Make sure the controller enabling switch is turned off.
2. Switch on the power supply of all devices. The STATUS-LED on the front of the device should now be active.

If the STATUS-LED is not active, there is a malfunction. If the seven-segment display indicates a number sequence, it is displaying an error message. You have to take care of the corresponding problem. In this case please continue with chapter 9.2.2 Error messages (page 98). If the device displays nothing, follow these steps:

1. Switch off the power supply.
2. Wait 5 minutes, so the DC bus can discharge.
3. Check all connection cables.
4. Check the functionality of the 24 V power supply.
5. Switch the power supply back on.

## 9 Service functions and error messages

### 9.1 Protection and service functions

#### 9.1.1 Overview

The servo positioning controller LV-servoTEC S2 1xx has a powerful sensor analysis, which monitors the proper functioning of the controller, power output stage, motor and communication with the outside world. All occurring errors are stored in an internal error memory. Most errors will cause the controller unit to shut down the servo positioning controller and the power output stage. They can only be switched on again after the error memory has been deleted by acknowledging the error and after the error has been eliminated or no longer exists.

A powerful sensor analysis and monitoring function provides operational safety:

- Measuring of motor temperature
- Measuring of power section temperature
- Detection of ground faults (PE)
- Detection of connections between two motor phases
- Detection of overvoltage in the DC bus
- Detection of errors with the internal voltage supply
- Failure of the supply voltage.

If the 24 V DC supply voltage fails, ca. 20 ms remain to e.g. save parameters and shut down the controller properly.

#### 9.1.2 Overcurrent and short-circuit monitoring

This monitor responds as soon as the current in the DC bus exceeds twice the maximum current of the controller. It detects short-circuits between two motor phases as well as short-circuits at the motor output terminals against the positive and negative reference potential of the DC bus and against PE. If the error monitoring detects an overcurrent, the power output stage will shut down immediately to guarantee the ability to withstand short-circuits.

#### 9.1.3 Overvoltage monitoring for the DC bus

This monitor responds, if the DC bus voltage exceeds the operating voltage range. The power output stage will be shut down.

#### 9.1.4 Temperature monitoring of the heat sink

The heat sink temperature of the power output stage is measured with a linear temperature sensor. The temperature limit varies from device to device. Approx. 5°C underneath the limit value a temperature warning is issued.

### 9.1.5 Monitoring of the motor

The servo positioning controller LV-servoTEC S2 1xx has the following protective functions to monitor the motor and the connected encoder:

Monitoring of the encoder: An error in the shaft encoder shuts down the power output stage. In the case of resolvers, e.g. the encoder signal is monitored. In the case of incremental encoders the commutation signals are checked. Other „intelligent“ encoders provide further means of error detection

Measurement and monitoring of the motor temperature: The servo positioning controller LV-servoTEC S2 1xx has a digital and an analog input for the detection and monitoring of the motor temperature. The analog signal detection also supports non-linear sensors. The following temperature sensors can be selected:

At [X6]: Digital input for PTCs, normally closed contacts and normally open contacts.

At [X2A] and [X2B]: Normally closed contacts and analog sensors, type KTY. Other sensors (NTC, PTC) may require a corresponding SW adaptation.

### 9.1.6 I<sup>2</sup>t monitoring

The servo positioning controller LV-servoTEC S2 1xx comprises an I<sup>2</sup>t monitoring to limit the average power loss in the power output stage and in the motor. Since the occurring power loss in the power electronics and in the motor in the worst case increases square with the current, the squared current value is assumed as the measure for the power loss.

### 9.1.7 Power monitoring for the brake chopper

Power monitoring for the internal brake resistor is implemented in the operating software.

### 9.1.8 I<sup>2</sup>t monitoring for the PFC stage

I<sup>2</sup>t monitoring for the PFC is implemented in the operating software.

### 9.1.9 Initial operation status

Servo positioning controller, which are sent to IEF-Werner GmbH for service, will be equipped with a different firmware and other parameters for testing purposes.

Before the next initial operation at the consumer the servo positioning controller LV-servoTEC S2 1xx must be parameterized again. The parameterisation software S2 Commander™ queries the initial operation status and asks the user to parameterize the servo positioning controller. At the same time the device shows an “A” on the seven-segment display to indicate that it is ready but not yet parameterized

### 9.1.10 Operating hours meter





An operating hours meter is implemented, which has been designed for at least 200 000 operating hours. The operating hours meter is displayed in the parameterisation software S2Commander™.

## 9.2 Display of operating mode and error messages

### 9.2.1 Operating mode and error display

The system supports a seven-segment display. The following table describes the display and the meaning of the symbols shown:

Table 40: Operating mode and error display

Display	Meaning
	In this operating mode the outer bLV-servoTEC S2 "rotate", depending on the speed resp. the position of the rotor.  If the drive is enabled, the center bar of the seven-segment display is on.
	
	The servo positioning controller LV-servoTEC S2 is yet to be parameterised. (seven-segment display = A)
	Operating mode torque control, the two bLV-servoTEC S2 on the left hand of the display are on. (seven-segment display = I)
P xxx	Positioning, "xxx" stands for the position set number. The numbers are successively indicated.
PH x	Homing is active, „x“ stands for the active phase of the homing run. 0 : Search phase 1 : Crawling phase 2 : Positioning to zero position The Figure s are successively indicated.
E xxy	Error message / number with index "xx" and subindex "y"
-xxy-	Warning message / number with Index „xx“ and subindex „y“. A warning is displayed at least twice on the seven-segment-display.
	Option „Safe Stop“ active for the LV-servoTEC S2 2300 devices. (seven-segment display = H, blinking with a frequency of 2Hz)

## 9.2.2 Error messages

If an error occurs, the servo positioning controller LV-servoTEC S2 will cyclically show an error message in its seven-segment display. The error message is comprised of an E (for Error), a main index and a sub index, e.g.: E 0 1 0.

Warnings have the same code numbers as error messages. As a distinguishing feature, warnings have centre bar before and after the number, e.g. - 1 7 0 -.

The following Table 41: Error messages summarizes the meaning and corresponding measures. A subindex “\*\*” means that there are a number of errors which are explained in further documentation.

The error messages with the main index 00 do not reflect run time errors. They contain information and in general there are no measures required by the user. They occur in the error buffer only but will not be shown on the 7-segment display.

Table 41: Error messages

Error messages		Meaning of error message	Measures
Main-index	Sub-index		
00	0	Invalid error	Information: An invalid (corrupted) entry in the error buffer is marked by this error number. No measures required.
	1	Invalid error detected and corrected	Information: An invalid (corrupted) error entry is detected and corrected. The Debug information stores the initially found error number. No measures required.
	2	Error cleared	Information: The active errors have been cleared No measures required.
	4	Serial number / device type changed (change of modules)	Information: A flexible error buffer (service module) has been plugged into another device No measures required.
01	0	Stack overflow	Incorrect firmware? If necessary, reload the standard firmware again. Contact the Technical Support
02	0	Undervoltage of DC-bus	Error reaction set to “disable drive”? Check (measure) the intermediate circuit voltage
03	0	Overtemperature analogue motor	Motor too hot? Check the parameterization (current controller, current limitation). Suitable sensor?
	1	Overtemperature digital motor	Sensor defective? Error also occurs if sensor is bypassed: device defective.
	2	Overtemperature motor analog wire break	Check cables of temperature sensor (broken wire)
	4	Overtemperature motor analog short circuit	Check the parameterization (wire break monitoring)  Check the parameterization (short circuit monitoring)

Error messages		Meaning of error message	Measures
Main-index	Sub-index		
04	0	Overtemperature of the power stage	Plausible temperature display? Check the installation conditions, filter mats of fan dirty? Device fan defective?
	1	Overtemperature in the DC-bus	Device fan defective
05	0	Internal undervoltage supply 1	The error cannot be eliminated by the user. Contact the Technical Support and - if necessary - send the servo positioning controller to the sales representative.
	1	Internal undervoltage supply 2	
	2	Driver voltage fault	
	3	Undervoltage of digital I/O	Check the outputs for short-circuits or specific load. If necessary, contact the Technical Support.
4	Overcurrent of digital I/O		
06	0	Short circuit in the power stage	Power stage defective? Motor defective? Short-circuit in cable?
	1	Overcurrent brake chopper	Check the braking chopper circuit (connections). Check the external brake resistor (if included). If necessary, contact the Technical Support.
07	0	Overvoltage	Check connection to braking resistor (internal / external) Braking resistor overloaded? Check rating.
08	0	Angle encoder error resolver	See measures 08-2 .. 08-7
	1	Sense of rotation of the serial and incremental position evaluation is not identical	A and B-track are mixed up. Correct (check) the connection of the tracks.
	2	Error of track signals Z0 Incremental encoder	Angle encoder connected? Angle encoder cable defective?
	3	Error of track signals Z1 Incremental encoder	Angle encoder defective?
	4	Error of track signals of digital incremental encoder	Check the configuration of the angle encoder interface. The encoder signals are disturbed: check the installation for compliance with EMC recommendations.
	5	Error of Hall signals incremental encoder	
	6	Communication error encoder	
	7	Signal amplitude incremental track erroneous	
	8	Internal encoder error	
9	Encoder at X2B not supported	Please contact the Technical Support.	
09	0	Old encoder parameter set (type LV-servoTEC S2)	Please read this documentation or contact the Technical Support.
	1	Encoder parameter set cannot be decoded	
	2	Unknown encoder parameter set version	

Error messages		Meaning of error message	Measures
Main-index	Sub-index		
	3	Corrupted encoder parameter set data	
	7	Encoder EEPROM has write protection	
	9	Too small memory size of encoder EEPROM	
10	0	Overspeed (motor overspeed protection)	Encoder offset angle correct? Overspeed protection limit too small?
11	0	Error at start of homing run	No controller enabling
	1	Error during homing run	Homing has been interrupted e.g. by disabling the drive.
	2	Homing run: No valid index pulse	The required index pulse is missing
	3	Homing run: timeout	The maximum time parameterized for homing has been consummated before the homing run has been completed.
	4	Homing run : Wrong or invalid limit switch	The associated limit switch is not connected. Limit switches mixed up
	5	Homing run: !t / following error	Unsuitable parameterisation of acceleration ramps. Invalid stop reached, e.g. because no homing switch is connected. Contact the Technical Support.
	6	Homing run: End of homming distance	The maximum homing distance has been travelled but the reference point of the destination of the homing run have not been reached.
12	0	CAN: Two nodes with the same ID	Check the configuration of the devices connected to the CAN bus.
	1	CAN: Communication error / bus OFF	The CAN chip has switched off the communication due to communication errors (BUS OFF).
	2	CAN: Communication error on send	The signals are disturbed during the transmission of messages.
	3	CAN: Communication error on receive	The signals are disturbed during the reception of messages.
	4	No Node Guarding-telegram during the parameterized time received	Equalize the cycle time of the remote frames with the PLC resp. failure of the PLC. Signals interfered?
	9	CAN: Protocol error	Please contact the Technical Support.
13	0	Timeout CAN-Bus	Check the timeout parameter for CAN bus.
14	0	Insufficient supply for indentification	The available intermediate circuit voltage is too low for the measurement.
	1	Identification current controller : measurement Cycle insufficient	The automatic parameter identification process delivers a time constant beyond the parameterisation value range. The parameters must be optimized manually.
	2	Power stage could not be enabled	The power stage has not been enabled. Check the connection of DIN4.

Error messages		Meaning of error message	Measures
Main-index	Sub-index		
	3	Power stage prematurely disabled	The power stage has been disabled while the identification process was running.
	4	Identification does not support selected resolver	The identification cannot be performed with the present angle encoder settings. Check the configuration of the angle encoder. If necessary, contact the Technical Support.
	5	No index pulse detected	The index pulse could not be found after the maximum number of electrical rotations. Check the index pulse signal.
	6	Invalid hall signals	The pulse sequence or the segmentation of the Hall signals is unsuitable. Check the connection. If necessary, contact the Technical Support.
	7	Identification not possible	Ensure a sufficient intermediate circuit voltage. Rotor blocked?
	8	Invalid number of poles pairs	The number of pairs of poles calculated is beyond the parameterisation range. Check the motor data sheet. If necessary, contact the Technical Support.
	9	Automatic parameter identification: General error	Take further information from the additional error data and contact the Technical Support.
15	0	Division by zero	Please contact the Technical Support.
	1	Out of range error	
	2	Mathematical underflow	
16	0	Erroneous program execution	Please contact the Technical Support.
	1	Illegal interrupt	
	2	Initialization error	
	3	Unexpected state	
17	0	Max. following error exceeded	Increase error window. Acceleration parameterization too large
	1	Encoder difference control	Check the connection of the encoders. Check the parameterized gear.
18	0	Warning level analogue motor temperature	Motor too hot? Check the parameterization (current controller, current limitation) Suitable sensor? Sensor defective? Error also occurs if sensor is bypassed: device defective
	1	Warning level temperature power stage	Plausible temperature display? Check the installation conditions, filter mats of fan dirty? Device fan defective?
21	0	Error 1 current measurement U	The error cannot be eliminated by the user. Contact the Technical Support and - if necessary - send the servo positioning controller to the sales representative.
	1	Error 1 current measurement V	
	2	Error 2 current measurement U	
	3	Error 2 current measurement V	

Error messages		Meaning of error message	Measures
Main-index	Sub-index		
22	0	PROFIBUS: Wrong initialization	Technology module defective? Contact the Technical Support.
	1	PROFIBUS: reserved	
	2	Communication error PROFIBUS	Check the slave address. Check the bus terminators. Check the cabling.
	3	PROFIBUS: Invalid slave address	The communication was started with slave address 126. Select another slave address.
	4	PROFIBUS: Range overflow	Mathematical error during the conversion of physical units. The value range of the data and of the physical units do not match. Contact the Technical Support.
25	0	Invalid device type	Technical defect or unsuitable firmware. Contact the Technical Support and - if necessary - send the servo positioning controller to the sales representative.
	1	Device type not supported	
	2	HW revision not supported	
	3	Device function restricted	Contact the Technical Support and - if necessary - send the servo positioning controller to the sales representative.
26	0	No user parameter set	Load the default parameter set. If the error continues, contact the Technical Support.
	1	Checksum error	Please contact the Technical Support.
	2	Flash: Error during write-operation	
	3	Flash: Error during erase-operation	
	4	Flash: Error in internal flash	The error cannot be eliminated by the user. Please contact the technical support team.
	5	No calibration data	
	6	Missing user position data sets	Simply perform save & reset. Load the default parameter set. If the error continues to occur, contact the Technical Support.
	7	Faulty data tables (CAM)	Load default parameter set, reload the parameter set if necessary. If the error continues, contact the Technical Support.
27	0	Following error warning level	Check the parameterisation of the following error. Motor blocked?
28	0	Hours-run meter missing	Please contact the Technical Support.
	1	Hours-run meter: write error	
	2	Hours-run meter corrected	Acknowledge the error. If the error continues to occur, contact the Technical Support.
	3	Hours-run meter converted	
30	0	Internal calculation error	Please contact the Technical Support.
31	0	I <sup>2</sup> t motor	Motor blocked?
	1	I <sup>2</sup> t servo controller	Check the power rating of the drive package.

Error messages		Meaning of error message	Measures
Main-index	Sub-index		
	2	I <sub>rt</sub> -PFC	Check the power rating of the drive package. Select operation without PFC?
	3	I <sub>rt</sub> -Break resistor	Braking resistor overloaded. Use external braking resistor?
	4	I <sub>rt</sub> real power overload	Reduce the real power of the drive
32	0	Loading period DC-bus exceeded	Please contact the Technical Support.
	1	Undervoltage for active PFC	
	5	Braking chopper overload. Intermediate circuit couldn't be discharged.	
	6	Discharge period DC-bus exceeded	
	7	Failure of Power supply for controller enable	No intermediate circuit voltage. Angle encoder not ready.
	8	Supply power breakdown at controller enable	Interruption / mains failure of power supply. Check the supply.
	9	Phase failure	Failure of one or several phases. Check the power supply.
33	0	Following error encoder emulation	Please contact the Technical Support.
34	0	No synchronisation via field bus	Failure of synchronization messages from master?
	1	Field bus synchronisation error	Failure of synchronization messages from master? Parameterization of synchronization interval too small?
35	0	Speed protection of Linear motor	The encoder signals are disturbed. Check the installation for compliance with EMC recommendations.
	5	Error during the determination of the commutation position	For this motor an improper method has been chosen. Please contact the Technical Support.
36	0	Parameter limited	Check the value range of the parameter stated.
	1	Parameter not accepted	
37	0 ... 9	SERCOS field bus	Refer to the SERCOS Manual or contact the Technical Support.
38	0 ... 9	SERCOS field bus	Refer to the SERCOS Manual or contact the Technical Support.
39	0 ... 6	SERCOS field bus	Refer to the SERCOS Manual or contact the Technical Support.
40	0	Negative SW limit switch	The position setpoint has reached or exceeded the respective software limit switch. Check the target data.
	1	Positive SW limit switch	Check the positioning range.
	2	Target position behind the negative SW limit switch	The start of a positioning run was suppressed as the target lies beyond the respective software limit switch. Check the target data.
	3	Target position behind the positive SW limit switch	Check the positioning range.

Error messages		Meaning of error message	Measures
Main-index	Sub-index		
41	0	Course program: Synchronization error	Please contact the Technical Support
	1	Course program: Unknown command	
	2	Course program: Invalid branch destination	
42	0	Positioning: Missing following position: Stop	The positioning target cannot be reached with the current positioning options or the current boundary conditions. Check the positioning parameters.
	1	Positioning: Reversing the direction not allowed: Stop	
	2	Positioning: Reversing the direction not allowed after stop	
	3	Start positioning rejected: wrong mode of operation	The change of the mode of operation could not be performed by the position set.
	5	Rotary axis: direction of rotation is not allowed	According to the selected mode of the rotary axis the calculated direction of rotation is not allowed. Check the selected mode.
	9	Error at positioning start	Speed limitation exceeded or positioning data set inhibited
43	0	Limit switch: Negative setpoint inhibited	The drive has left the intended motion range. Technical defect in the system?
	1	Limit switch: Positive setpoint inhibited	
	2	Limit switch: Positioning suppressed	
45	0	Supply voltage cannot be switched off	Technical defect?
	1	Supply voltage cannot be switched on	Contact the Technical Support.
	2	Supply voltage was activated	
47	0	Timeout (thread mode, Set-up mode)	The speed has not been fallen below the required value for the thread mode (set-up mode) in time. Check the processing of the request by the PLC.
50	0	CAN: Too much synchronous PDOs	Please contact the Technical Support.
60	0	Ethernet user specific (1)	Please contact the Technical Support.
61	0	Ethernet user specific (2)	Please contact the Technical Support.
62	0	EtherCAT: Initialization error	No EtherCAT bus available
	1	EtherCAT: Initialization error	Error in hardware
	2	EtherCAT: Protocol error	No CAN over EtherCAT are used.
	3	EtherCAT: Invalid RPDO length	Sync Manager 2: Buffer size too large.
	4	EtherCAT: Invalid TPDO length	Sync Manager 3: Buffer size too large.

Error messages		Meaning of error message	Measures
Main-index	Sub-index		
	5	EtherCAT: Erroneous cyclic communication	Safety shutdown: Failure of cyclic data transfer.
63	0	EtherCAT: Defective module	Error in the hardware.
	1	EtherCAT: Invalid data	Wrong type of telegram
	2	EtherCAT: TPDO data has not been read	Transmit buffer are full.
	3	EtherCAT: No distributed clocks active	Warning: Firmware synchronize system on the telegram is not on the distributed clocks system
	4	Missing SYNC message in IPO cycle	There are no sent telegrams into the IPO time slot.
64	0 .. 6	DeviceNet fieldbus (1)	Please contact the Technical Support.
65	0 .. 1	DeviceNet fieldbus (2)	Please contact the Technical Support.
70	1 .. 3	FHPP fieldbus (2)	Please contact the Technical Support.
71	0 .. 2	FHPP fieldbus	Please contact the Technical Support.
80	0	Time overflow current controller IRQ	Please contact the Technical Support.
	1	Time Overflow speed controller IRQ	
	2	Time Overflow position controller IRQ	
	3	Time Overflow interpolator IRQ	
81	4	Time overflow low-level IRQ	Please contact the Technical Support.
	5	Time overflow MDC IRQ	
82	0	Sequencing control	Normally just information. No measures required.
83	0	Invalid Technology module	Insert the technology module into the other slot, refer to the documentation of the module.
	1	Technology module not supported	Please contact the Technical Support.
	2	Technology module: HW revision not supported	
	3	Technology module: Write error	
	4	Technology module: MC 2000 watchdog	
90	0	Missing hardware component (SRAM)	Please contact the Technical Support.
	1	Missing hardware component (FLASH)	
	2	Error during booting of FPGA	
	3	Error during starting of SD-ADUs	
	4	Synchronization error SD-ADU after start	

Error messages		Meaning of error message	Measures
Main-index	Sub-index		
	5	SD-ADU not synchronous	
	6	Trigger error	
	9	DEBUG-Firmware loaded	
91	0	Internal initialisation error	Please contact the Technical Support.

Error message		Error message explanation	Measures
Main index	Subindex		
08	0	Resolver angle encoder error	Angle encoder connected? Angle encoder cable defective? Angle encoder defective? Check the configuration of the angle encoder interface. The encoder signals are disturbed: Check the installation for compliance with EMC recommendations.
	2	Incremental encoder Z0 trace signals error	
	3	Incremental encoder Z1 trace signals error	
	4	Digital incremental encoder trace signals error	
	5	Incremental encoder Hall generator signals error	
	7	Incorrect signal amplitude of incremental tracks	
	8	Internal angle encoder error	
	9	Angle encoder at X2B not supported	Contact the technical support team.
09	0	Outdated angle encoder parameter set (type LV-servoTEC S2)	The data in the angle encoder will be converted as far as possible. To avoid this message save the data to the EEPROM of the angle encoder (reformatting)
	1	Angle encoder parameter set cannot be decoded	Angle encoder defective? Check the configuration of the angle encoder interface. The encoder signals are disturbed: Check the installation for compliance with EMC recommendations.
	2	Unknown version of angle encoder parameter set	Conversion impossible. Save the data again in the angle encoder.
	3	Defective data structure of angle encoder parameter set	Redetermine the data if necessary and save them again in the angle encoder.
	7	Write-protected angle encoder EEPROM	Please contact the technical support team.
	9	Angle encoder EEPROM not sufficient	Please contact the technical support team.
10	0	Overspeed (spinning protection)	Check the parameterization of the limit value. Incorrect offset angle?

Error message		Error message explanation	Measures
Main index	Subindex		
11	0	Homing: Error at start	No controller enabling.
	1	Error during homing	Homing has been interrupted, for example because the controller is no longer enabled.
	2	Homing: Reset pulse error	The necessary index pulse is missing
	3	Homing: Timeout	The maximum time parameterized for homing has been reached before the homing run could be completed.
	4	Homing: Wrong/invalid limit switch	The associated limit switch is not connected. Limit switches mixed up?
	5	Homing: I <sup>2</sup> t / lag error	Unsuitable parameterization of acceleration ramps. Invalid stop reached, e.g. because no homing switch is connected. Contact the technical support team.
	6	Homing: End of search path	The maximum homing distance has been travelled but the reference point of the destination of the homing run have not been reached.
12	0	CAN bus: Double node number	Check the configuration of the devices connected to the CAN bus.
	1	CAN communication error: Bus Off	The CAN chip has switched off the communication due to communication errors (BUS OFF).
	2	CAN communication error during transmission	The signals are disturbed during the transmission of messages.
	3	CAN communication error during reception	The signals are disturbed during the reception of messages.
	9	CAN: Protocol error	Check the command syntax of the control (record the data traffic).
13	0	CAN bus: Timeout	Check CAN parameterization

Error message		Error message explanation	Measures
Main index	Subindex		
14	0	Insufficient supply for identification	The available intermediate circuit voltage is too low for the measurement.
	1	Current controller identification: Insufficient measuring cycle	The automatic parameter identification process delivers a time constant beyond the parameterization value range. The parameters must be optimized manually.
	2	Output stage could not be enabled	The power stage has not been enabled. Check the connection of DIN4.
	3	Output stage has been switched off prematurely	The power stage has been disabled while the identification process was running.
	4	Identification does not support the encoder type set	The identification cannot be performed with the present angle encoder settings. Check the configuration of the angle encoder. If necessary, contact the technical support team.
	5	Reset pulse could not be found	The index pulse could not be found after the maximum number of electrical rotations. Check the index pulse signal.
	6	Hall signals invalid	The pulse sequence or the segmentation of the Hall signals is unsuitable. Check the connection. If necessary, contact the technical support team.
	7	Identification impossible	Ensure a sufficient intermediate circuit voltage. Rotor blocked?
	8	Invalid number of pairs of poles	The number of pairs of poles calculated is beyond the parameterization range. Check the motor data sheet. If necessary, contact the technical support team.
15	0	Division by 0	Please contact the technical support team.
	1	Range exceeded	
16	0	Error during program execution	Please contact the technical support team.
	1	Illegal interrupt	
	2	Initialisation error	
	3	Unexpected state	

Error message		Error message explanation	Measures
Main index	Subindex		
17	0	Lag error limit exceeded	Increase the error window. Acceleration parameterization too high.
	1	Encoder difference monitoring	External angle encoder not connected or defective? The deviation fluctuates, e.g. due to gear slackness. If necessary, increase the shutdown threshold.
21	0	Error 1 current measurement U	The error cannot be eliminated by the user. Send the servo positioning controller to the distributor.
	1	Error 1 current measurement V	
	2	Error 2 current measurement U	
	3	Error 2 current measurement V	
22	0	PROFIBUS: Incorrect initialisation	Technology module defective? Please contact the technical support team.
	1	PROFIBUS: reserved	
	2	PROFIBUS communication error	Check the slave address set. Check the bus termination. Check the wiring.
	3	PROFIBUS: Invalid slave address	The communication was started with slave address 126. Select another slave address.
	4	PROFIBUS: Error in value range	Mathematical error during the conversion of physical units. The value ranges of the data and of the physical units do not match. Contact the technical support team.
25	0	Invalid device type	The error cannot be eliminated by the user. Send the servo controller to the distributor.
	1	Device type not supported	
	2	HW revision not supported	Check the firmware version. If necessary, order an update from the technical support department.
	3	Device functionality restricted	The desired functionality is not enabled for the device and has to be enabled by IEF-Werner. Send in the device.

Error message		Error message explanation	Measures
Main index	Subindex		
26	0	Missing user parameter set	Load the default parameter set. If the error continues to occur, send the servo positioning controller to the distributor.
	1	Checksum error	The error cannot be eliminated by the user. Please contact the technical support team.
	2	Flash: Write error	
	3	Flash: Delete error	
	4	Flash: Internal flash error	
	5	Missing calibration data	
	6	Missing user position data set	Adjust the position and save it to the servo positioning controller.
27	0	Lag error warning threshold	Check the parameterization of the lag error. Motor blocked?
28	0	Missing operating hour meter	Acknowledge the error. If the error occurs again, please contact the technical support team.
	1	Operating hour meter: Write error	
	2	Operating hour meter corrected	
	3	Operating hour meter converted	
30	0	Internal conversion error	Please contact the technical support team.
31	0	Motor I <sup>2</sup> t	Motor blocked?
	1	Servo controller I <sup>2</sup> t	Check the power sizing of the drive package.
	2	PFC I <sup>2</sup> t	Check the power rating of the drive. Select operation without PFC?
	3	Braking resistor I <sup>2</sup> t	Braking resistor overloaded. Use external braking resistor?
32	0	DC-link charging time exceeded	Please contact the technical support team.
	1	Undervoltage for active PFC	
	5	Brake chopper overload	
	6	DC-link discharge time exceeded	
	7	No power supply available for controller enabling	No intermediate circuit voltage. Angle encoder not ready.
	8	Power supply failure during controller enabling	Interruption / mains failure of power supply Check the power supply.
	9	Phase failure	Failure of one or several phases. Check the power supply.
33	0	Encoder emulation lag error	Please contact the technical support team.
34	0	No synchronisation via field bus	Failure of synchronisation messages from master?
	1	Field bus synchronisation error	Failure of synchronisation messages from master?  Parameterization of synchronisation interval too small?

Error message		Error message explanation	Measures
Main index	Subindex		
35	0	Linear motor spinning protection	The encoder signals are disturbed. Check the installation for compliance with EMC recommendations.
36	0	Parameter limited	Check the user parameters set.
	1	Parameter not accepted	
37	0 ... 9	SERCOS field bus	Please read the SERCOS manual and contact the technical support team if necessary.
38	0 ... 9	SERCOS field bus	Please read the SERCOS manual and contact the technical support team if necessary.
40	0	Negative SW limit switch reached	The position setpoint has reached or exceeded the respective software limit switch.
	1	Positive SW limit switch reached	Check the target data. Check the positioning range.
	2	Target position after the negative limit switch	The start of a positioning run was suppressed as the target lies beyond the respective software limit switch. Check the target data. Check the positioning range.
	3	Target position after the positive limit switch	

Error message		Error message explanation	Measures
Main index	Subindex		
42	0	Positioning: Drive stops automatically due to missing follow-up positioning	The positioning target cannot be reached with the current positioning options or the current boundary conditions.
	1	Positioning: Drive stops as rotation reversal is not allowed	Check the parameterization of the position sets involved.
	2	Positioning: Illegal rotation reversal after "stop"	The target cannot be reached due to the change in boundary conditions.
43	0	Limit switches: Negative setpoint blocked	The drive has left the intended motion range.
	1	Limit switches: Positive setpoint blocked	Technical defect in the system?
	2	Limit switches: Positioning suppressed	
45	0	Driver supply cannot be deactivated	<b><i>The error "Failure of driver supply" may be safety-critical. Please contact the technical support team.</i></b>
	1	Driver supply cannot be activated	
	2	Driver supply has been activated	
50	0	Too many synchronous PDOs	Deactivate PDOs or increase the SYNC interval. The maximum number of PDOs must not exceed the factor $tp$ (cycle times).
60	0	Ethernet in general (1)	Please contact the technical support team.
61	0	Ethernet in general (2)	Please contact the technical support team.
80	0	Overflow current controller IRQ	Please contact the technical support team.
	1	Overflow speed controller IRQ	
	2	Overflow position controller IRQ	
	3	Overflow interpolator IRQ	
81	0	Overflow low-level IRQ	Please contact the technical support team.
	1	Overflow MDC IRQ	
82	0	Sequencing control: General incident	No measures required

Error message		Error message explanation	Measures
Main index	Subindex		
83	0	Invalid technology module	Incorrect slot / incorrect HW revision. Check the technology module. If necessary, contact the technical support team.
	1	Technology module not supported	Load matching firmware? Contact the technical support team if necessary.
	2	Technology module: HW revision not supported	Load matching firmware? Contact the technical support team if necessary.
90	0	Unknown hardware component	Please contact the technical support team.
	1	Error at FPGA boot-up	
	2	Error at SD-ADU start	
	3	SD-ADU synchronisation error after start	
	4	SD-ADU not synchronous	
	5	SD-ADU not synchronous	
	9	DEBUG firmware loaded	
91	0	Internal initialisation error	Please contact the technical support team.

## 10 Technologiemodule

### 10.1 SERCOS module

#### 10.1.1 Product description

The SERCOS module is used to connect the LV-servoTEC S2 2300 servo positioning controller to a SERCOS-compatible CNC control. The communication on the SERCOS bus uses a ring-shaped optical fibre link with transmission rates of up to 16 Mbaud. If six servo positioning controllers are connected to one bus, setpoints and actual values (position, speed and torque values) can be exchanged with the CNC control every 500 µs.

A special feature of the SERCOS bus is the synchronisation of all the devices connected to the bus. If several LV-servoTEC S2 servo positioning controllers are connected, the internal controllers and output stages of the servo positioning controllers operate in a phase-locked manner.

The SERCOS module **can only be used in technology slot TECH2.**

#### 10.1.2 Technical data

Table 42: Technical data: SERCOS module: Ambient conditions, dimensions and weight

Range	Values
Storage temperature range	-25 °C to +75°C
Operating temperature range / deratings	0°C to 50°C
Atmospheric humidity	0..90%, non-condensing
Altitude	up to 1000 m above msl
External dimensions (LxWxH):	approx. 92 x 65 x 19mm suitable for technology slot TECH2
Weight	approx. 50g

The following elements can be found on the front plate of the SERCOS module (see Figure 32)

- a green LED to indicate that the bus is ready for operation
- a connection for the optical waveguide receiver / type HFD 7000-402 (metal connection)
- a connection for the optical waveguide transmitter / type HFD 7000-210 (plastic connection)

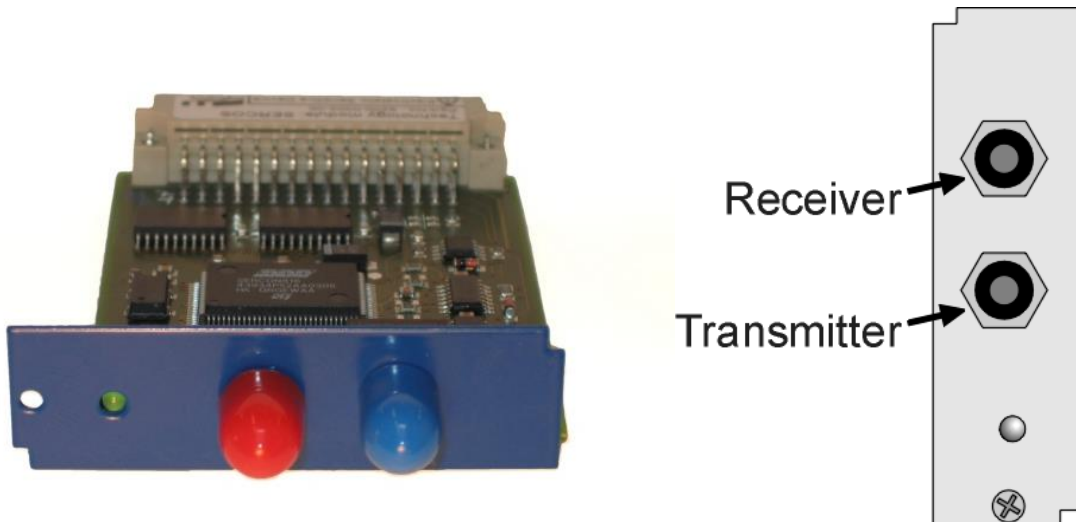

**Figure 32: SERCOS module: Front view**

### 10.1.3 Optical waveguide specification

More information concerning the type and setup of suitable optical waveguides can be found in the standard SERCOS literature, e.g.:

<http://www.sercos.org/>

Interests Group SERCOS interface e.V.  
Landhausstrasse 20, 70190 Stuttgart

Germany

## 10.2 EA88 interface technology module

### 10.2.1 Product description

The EA88 interface can be used in technology slot TECH1 or TECH2 of the LV-servoTEC S2 2300 servo positioning controller to extend the already existing digital IOs. Up to two EA88 interfaces can be supported simultaneously.

This technology module can be used to actuate up to 8 digital 24V outputs independently. In addition, 8 digital 24V inputs are available.

The EA88 interface has the following characteristics:

- Digital 24V inputs
- Digital 24V outputs which can be activated separately and loaded with 100 mA each
- MicroCombicon pin-and-socket connectors made by PHOENIX
- Pin-and-socket connectors via male multipoint connector in accordance with DIN 41612
- The inputs and outputs are floating due to the optocouplers
- The inputs and outputs are protected against short circuits and overload

### 10.2.2 Technical data

#### 10.2.2.1 General data

Table 43: Technical data: EA88 interface

Range	Values
Storage temperature range	-25 °C to +75°C
Operating temperature range / deratings	0°C to 50°C
Atmospheric humidity	0..90%, non-condensing
Altitude	Up to 1000 m above msl
External dimensions (LxWxH):	87mm x 65mm x 19mm; suitable for technology slot
Weight:	approx. 50g

### 10.2.2.2 Digital inputs

8 digital inputs 24V, protected against inverse polarity and short-circuit-proof.

Table 44: Digital inputs [X21]: EA88 interface

Parameter	Values
Input	High level switches the input
Nominal voltage	24 VDC
Voltage range	-30 V...30 V
"High" detection at	$U_{Ein} > 8 \text{ V}$
"Low" detection at	$U_{Ein} < 2 \text{ V}$
Hysteresis	$> 1 \text{ V}$
Input impedance	$\geq 4.7 \text{ k}\Omega$
Inverse polarity protection	Up to -30V
Switching delay up to port pin (low-high transition)	$< 100 \mu\text{s}$

### 10.2.2.3 Digital outputs

8 digital outputs 24V, protected against inverse polarity and short-circuit-proof, protection against thermal overload.

Table 45: Digital outputs [X22]: EA88 interface

Parameter	Values
Switch type	High-side switch
Nominal voltage	24 VDC
Voltage range	18 V...30 V
Output current (nominal)	$I_{L,nominal} = 100 \text{ mA}$
Voltage loss at $I_{L,nominal}$	$\leq 1 \text{ V}$
Residual current with switch in OFF position	$< 100 \mu\text{A}$
Protection against short-circuit / overcurrent	$> 500 \text{ mA}$ (approx. value)
Temperature protection	Shut-down if the temperature is too high, $T_J > 150^\circ$
Supply	Protection in the case of inductive loads and voltage supply via the output, also if the supply is turned off
Loads	$R > 220 \Omega$ ; L at random; $C < 10 \text{ nF}$
Switching delay as of port pin	$< 100 \mu\text{s}$

## 10.2.3 Pin assignment and cable specifications

### 10.2.3.1 Power supply

- The admissible input voltage range during operation is 15VDC...32VDC.
- The digital outputs of the EA88 technology module are supplied with voltage exclusively by an external 24VDC power supply. The nominal input voltage for the I/O supply is 24VDC.

If digital inputs are used, the reference potential GND24V of the 24VDC supply also has to be connected to the EA88 interface technology module

### 10.2.3.2 Pin assignments

The following elements can be found on the front plate of the EA88 interface:

- Connector [X21] for 8 digital inputs: PHOENIX MicroCombicon MC 0.5/9-G-2.5 (9-pin type)

Table 46: EA88: Connector [X21] for 8 digital inputs

Pin	1	2	3	4	5	6	7	8	9
Signal	GND 24V	In 1	In 2	In 3	In 4	In 5	In 6	In 7	In 8

- Connector [X22] for 8 digital outputs: PHOENIX MicroCombicon MC 0.5/10-G-2.5 (10-pin type)

Table 47: EA88: Connector [X22] for 8 digital outputs

Pin	1	2	3	4	5	6	7	8	9	10
Signal	GND 24V	Out 1	Out 2	Out 3	Out 4	Out 5	Out 6	Out 7	Out 8	+24VDC external

The following Figure 33 shows the position of the connectors and their numbering:

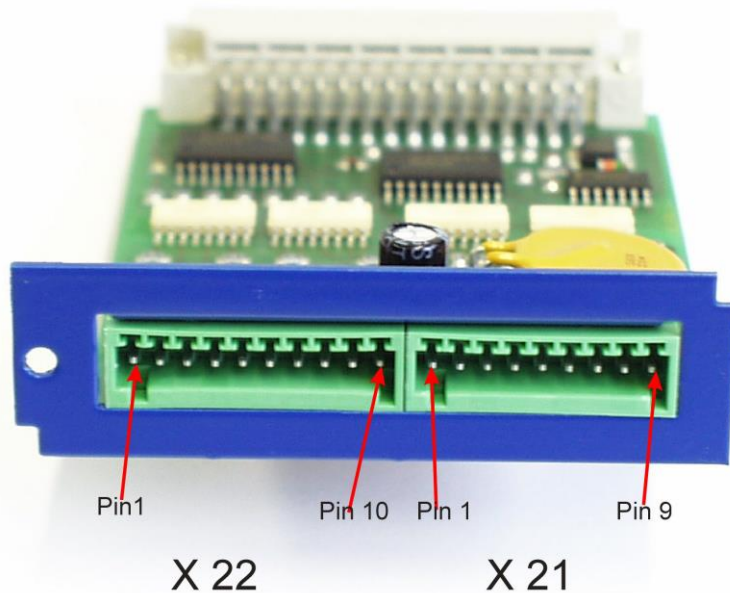

**Figure 33: Position of the pin-and-socket connectors [X21] and [X22] at the front plate**

#### 10.2.4 Mating connector

- Connector [X21] for 8 digital inputs: PHOENIX MicroCombicon FK-MC 0.5/9-ST-2.5
- Connector [X22] for 8 digital outputs: PHOENIX MicroCombicon FK-MC 0.5/10-ST-2.5

#### 10.2.5 Connection notes

The MicroCombicon mating connectors made by PHOENIX regarding [X21] (FK-MC 0.5/9-ST-2.5) and [X22] (FK-MC 0.5/10-ST-2.5) are supplied together with the EA88 interface technology module. The cables are connected in the form of crimp connections. To do so, strip the cable at a length of about 8 mm. Then insert it into the desired opening by pressing down the orange crimp lock using a suitable screwdriver, the tip of a ball-pen or something similar. Release the lock to fix the cable in place. The maximum admissible wire cross-section (wire gauge) is 0.5 mm<sup>2</sup> or AWG20.

If the EA88 interface is also used to control digital outputs, an additional external 24V supply voltage has to be connected to [X22], pin 10.

As the lines GND24V and +24Vext. have to transfer the entire current of all outputs connected, their cross-section has to be sized accordingly (recommended: AWG 20).

### 10.3 General installation notes for technology modules

**DANGER !**

Prior to installing technology modules, the LV-servoTEC S2 2300 servo positioning controller has to be disconnected from any current-carrying conductors. After the operating voltage has been disconnected, wait for 5 minutes so that the capacities in the LV-servoTEC S2 2300 servo positioning controller can be completely discharged.



Make sure that ESD protection measures are taken when handling technology modules.

Remove the front plate above the technology slot of the LV-servoTEC S2 2300 servo positioning controller using a suitable screwdriver. Then push the technology module into the open technology slot such that the circuit board is held by the lateral guides of the technology slot. Push the technology module in until it reaches the stop. Then screw technology module onto the housing of the servo positioning controller using the Phillips screw. Make sure that the front plate has conducting contact with the housing of the servo positioning controller (PE).