

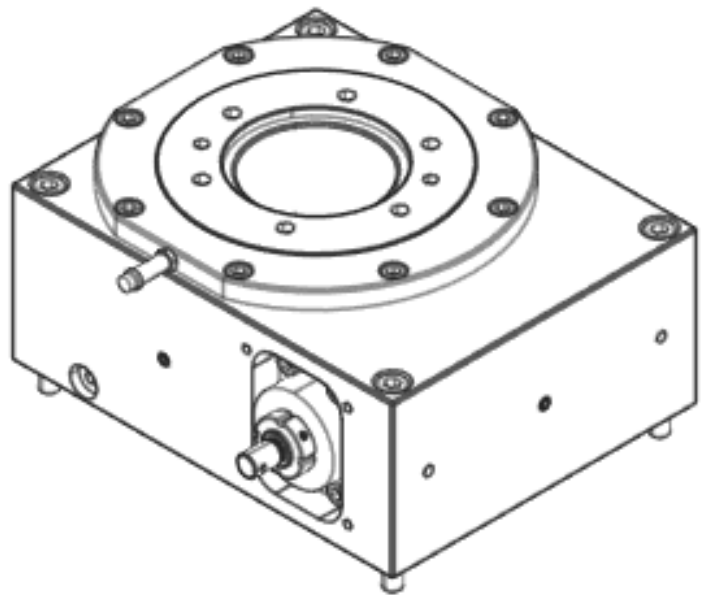

## Assembly instructions (translation)



Rotary table  
DT 160/200  
1605475

This documentation is intended only for the operating company and its personnel. The copyright of this documentation is owned by IEF-Werner GmbH. The content (texts, figures, drawings, graphics, plans, etc.) may not be reproduced or distributed, as a whole or in part, in printed or electronic form, without our prior written consent. This also applies to the unauthorized use for competition purposes or handing over and making accessible to third parties. All drawings, sketches and figures are the property of IEF-Werner GmbH. All rights reserved. Subject to change without notice.

**IEF-Werner GmbH**  
**Wendelhofstraße 6**  
**Germany-78120 Furtwangen**  
**Telephone: +49 7723-925-0**  
**info@ief-werner.de**

# Table of contents

<b>1 About this manual .....</b>	<b>4</b>
1.1 General information .....	4
1.2 Customer service department.....	4
1.3 Change history.....	4
1.4 Other applicable documents .....	4
1.5 Presentation of information .....	5
<b>2 Basic safety instructions.....</b>	<b>6</b>
2.1 Safety markings (pictograms and stickers).....	6
2.2 Obligations of the operating company / manufacturer.....	6
2.3 Target groups and personnel qualifications .....	6
2.4 Intended use .....	7
2.5 Residual risks .....	8
<b>3 Description .....</b>	<b>10</b>
3.1 Overview.....	10
3.2 Technical data and ambient conditions.....	11
3.3 Type plate / identification of the product .....	12
3.4 Scope of delivery and accessories .....	12
<b>4 Transport .....</b>	<b>13</b>
<b>5 Installation .....</b>	<b>14</b>
5.1 Installation accessories (optional).....	14
5.1.1 Motor attachment variants.....	14
5.1.2 Motor (axial motor attachment).....	14
5.1.3 Motor with belt gear .....	15
5.1.4 Reference switch .....	17
5.2 Installation.....	18
5.3 Making electrical connection .....	19
<b>6 Commissioning.....</b>	<b>21</b>
<b>7 Maintenance.....</b>	<b>22</b>
7.1 Spare parts and wear parts .....	22
7.2 Preparing the product for maintenance tasks.....	22
7.3 Lubricating.....	23
7.4 Tensioning the toothed belt (for belt gear) .....	24
7.5 Adjusting the play of the worm gear .....	24
<b>8 Fault rectification .....</b>	<b>27</b>
<b>9 Dismantling and disposal .....</b>	<b>29</b>

# 1 About this manual

## 1.1 General information

This manual is part of the machine/product and provides information concerning safe handling. The manual must therefore be kept on hand for the entire life cycle and must be accessible at all times.

The manual must be read, understood and complied with in all respects by all persons who work on and with the machine/product and who are responsible for the machine/product.

The illustrations are intended to clarify the content and may therefore deviate from reality.

## 1.2 Customer service department

In case of questions or problems, please contact our customer service:

IEF-Werner GmbH

Wendelhofstr. 6, 78120 Furtwangen, Germany

Telephone: +49 7723 / 925 - 222, E-mail: [service@ief-werner.de](mailto:service@ief-werner.de)

## 1.3 Change history

Version	Date	Changes
01	May 2024	First edition

## 1.4 Other applicable documents

Important documents can be downloaded from our homepage:  
<http://www.ief.de/dt-160200>.

The documentation for this product includes:

- the instructions (see homepage).
- the declaration of incorporation / UKCA Declaration of Incorporation (see homepage)
- the specific spare and wear parts list enclosed with the product.
- the models, parts lists and drawings (see homepage).
- the documentation of the installed supplier components.



## 1.5 Presentation of information

### Safety instructions

Safety instructions warn of dangerous situations. Depending on the severity of the hazard, safety instructions contain different signal words.

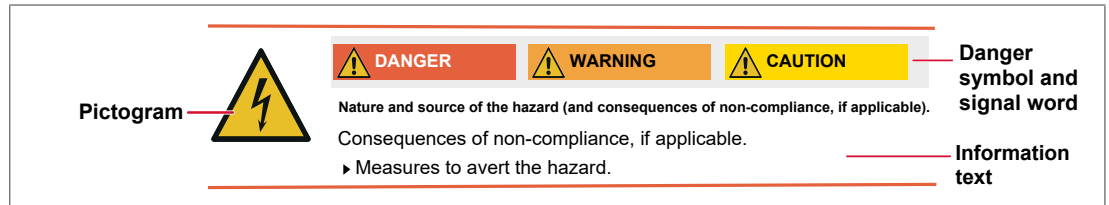
Safety instructions are structured as follows:



Danger symbol and signal word	Meaning
 <b>DANGER</b>	Indicates a dangerous situation in which death or serious bodily injury will occur, if the hazard prevention measures are not observed.
 <b>WARNING</b>	Indicates a dangerous situation in which death or serious bodily injury may occur, if the hazard prevention measures are not observed.
 <b>CAUTION</b>	Indicates a dangerous situation in which minor to moderate bodily injury may occur, if the hazard prevention measures are not observed.
<b>NOTE</b>	Indicates a situation in which damage to property (product/environment) may occur if the hazard prevention measures are not observed.

### Pictograms

The pictograms and safety markings used are explained in the following chapter: Safety markings (pictograms and stickers) [▶ 6].

### Symbols



Element / Symbol	Description
	Designates information and helpful tips.
■ ...	Designates bullet points.
✓	Designates prerequisites for instructions.
▶ ...	Designates instructions.
⇒ ...	Designates results of instructions.

## 2 Basic safety instructions

### 2.1 Safety markings (pictograms and stickers)

#### Dangers due to illegible safety markings

- ▶ Removed or illegible safety markings (e.g. due to soiling/damage/aggressive cleaning agents) lead to a high risk potential and must be replaced immediately.

Picto-gram	Description	Position
	Warning – hand injuries or danger of crushing!	Instructions
	Warning – electrical voltage!	Electric drives
	Warning – hot surface!	Electric drives

### 2.2 Obligations of the operating company / manufacturer

Ensure that

- the machine/product is only operated in technically faultless condition.
- damage, irregularities and faults are rectified immediately.
- the machine/product is only operated under the specified ambient conditions (see Intended use [▶ 8]) and within the specified capacity limits, connected loads and settings (see Technical data and ambient conditions [▶ 11]).
- markings on the product are taken into account.
- damaged safety markings, or those that have become illegible, must be replaced immediately, see Safety markings (pictograms and stickers) [▶ 6].

### 2.3 Target groups and personnel qualifications

This manual is intended for the operating company and all persons who work on and with the machine / product and are responsible for the machine / product. The operating company is the company in which the machine / product is set up and operated. The following table lists the qualifications required for the various tasks. In addition to the table, observe the information on personnel qualification in the individual chapters of this manual.

Group of people	Qualifications	Tasks
Specialists	<p>The specialist is able to carry out tasks on the machine/product due to his/her professional training, knowledge and experience. The specialist is specially trained for the environment in which he/she works and is familiar with the relevant standards and regulations. The specialist can also recognise and avoid possible dangers on his/her own.</p> <p>An example of a specialist is an electrician.</p>	Transport, assembly, commissioning, servicing, maintenance, troubleshooting, disassembly

Tab. 1: Personnel qualifications

## 2.4 Intended use

This incomplete machine is only intended to be installed in or joined together with other (incomplete) machines or equipment in order to form, together with other machines or equipment, a complete machine within the meaning of the Machinery Directive. Only after a conformity assessment procedure, in accordance with the Machinery Directive, has been carried out for the complete machine, may it be put into operation.

The operating company (manufacturer of the complete machine) must ensure that any danger zones still present are made safe and that the basic health and safety requirements are applied (For details see the declaration of incorporation).

### Function

The rotary table is used for the rotary positioning of workpieces and devices around a fixed centre point. The rotary table can be controlled electronically using suitable motorised systems.

The rotary table can be installed in any position. That is to say, that it can be mounted horizontally and vertically.

### Personnel qualifications

See Target groups and personnel qualifications [▶ 6].

### Environment



- The component is not suitable for operation in a vacuum or in liquids.
- Operation is only permitted in industrial buildings, on sufficiently load-bearing surfaces and in accordance with the defined ambient conditions (see Technical data and ambient conditions [▶ 11]).
- Only motors that have been approved by IEF-Werner GmbH for the specific application (travel speed, acceleration, load) may be fitted. If you have any questions, please contact the IEF-Werner GmbH service department.

## Non-intended use

Any use beyond the intended use or any other use is considered misuse. This includes:

- Failure to perform maintenance, service and repair measures.
- Failure to comply with the specified energy supply.
- Component must not be put into operation without additional protective or control measures.
- Component must not be used for transporting people and/or animals.
- Component must not be used in vehicles.
- Components must not come into direct contact with food.

## 2.5 Residual risks

Life-phase	Risk and avoidance	
In all life phases with vertical/inclined installation position	<p>Risk of injury (crushing, bumping)</p> <p>In the case of vertical/inclined installation position, moving parts can move/fall, in an uncontrolled manner, into the lower final position in a de-energised state (disconnection of the power supply/emergency stop/motor disassembly/...).</p> <ul style="list-style-type: none"> <li>▶ If necessary: Use the brake.</li> <li>▶ Before carrying out any work on the axle/in the area of the axle: Bring raised, moving parts into the final position or secure them, e.g. using supports, brakes or belts.</li> <li>▶ If a suspended load is positioned on edge or overhead and a person has to stand under this load, the load must also be secured against breaking or falling.</li> </ul>	
Operation	<p>Risk of crushing due to rotating movement.</p> <ul style="list-style-type: none"> <li>▶ Protect the travel range from being reached into.</li> <li>▶ Keep the travel range free of foreign objects.</li> <li>▶ Install appropriate protective devices (e.g. movable guards).</li> </ul>	
Operation	<p>Due to the movement of the rotary plate, there is a risk of hair or very thin objects being pulled in/wrapped up.</p> <ul style="list-style-type: none"> <li>▶ Install appropriate protective devices (e.g. movable guards).</li> <li>▶ Without protective device: Wear a hairnet if you have longer hair. Do not wear baggy or loose clothing (ties, shirt sleeves) and do not wear jewellery.</li> </ul>	
Maintenance, troubleshooting; disassembly	<p>Danger due to electrical voltage!</p> <ul style="list-style-type: none"> <li>▶ De-energise the machine before maintenance work and secure it from being switched on again.</li> </ul>	
Operation, maintenance, troubleshooting; disassembly	<p>Risk of burns due to hot surfaces!</p> <p>Motor housing can heat up and cause burns when touched.</p>	

Life-phase	Risk and avoidance	
	<ul style="list-style-type: none"><li>▶ Let the motor housing cool down before touching it (e.g. for maintenance tasks).</li></ul>	

Tab. 2: Residual risks

## 3 Description

### 3.1 Overview

#### Function

The rotary table is used for the rotary positioning of workpieces and devices around a fixed centre point. The rotary table can be controlled electronically using suitable motorised systems.

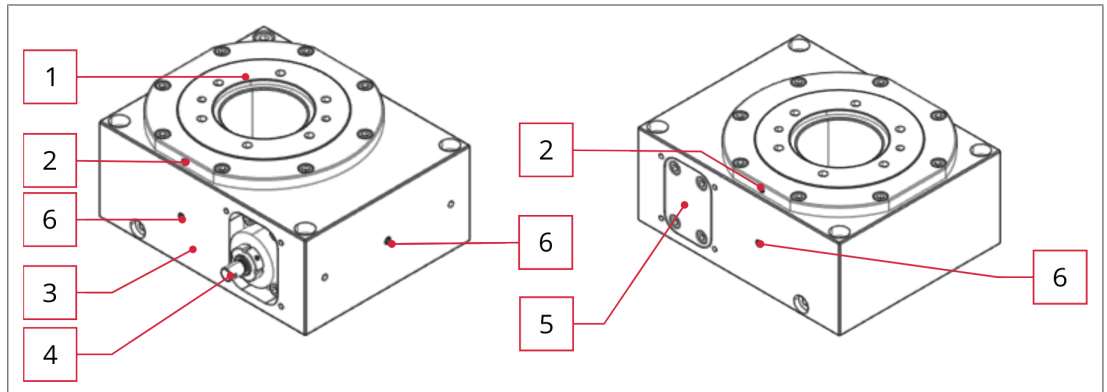

Fig. 1: Overview: rotary table

1 Rotary plate	2 Reference switch connection option (accessory)
3 Housing	4 Drive shaft
5 Bearing support Floating bearing	6 Funnel-type lubrication nipple

#### Rotary table with accessories

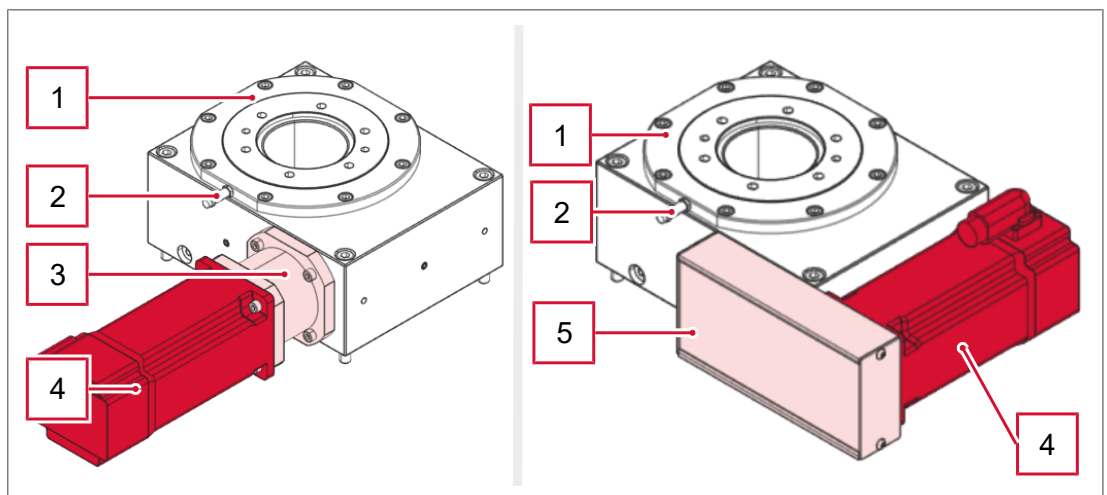

Fig. 2: Overview with accessories

1 Rotary table	2 Reference switch
3 Axial flange	4 Motor
5 Belt gear	

## 3.2 Technical data and ambient conditions

A type plate with (further) data is located on the machine / product.

### Dimensions of rotary table

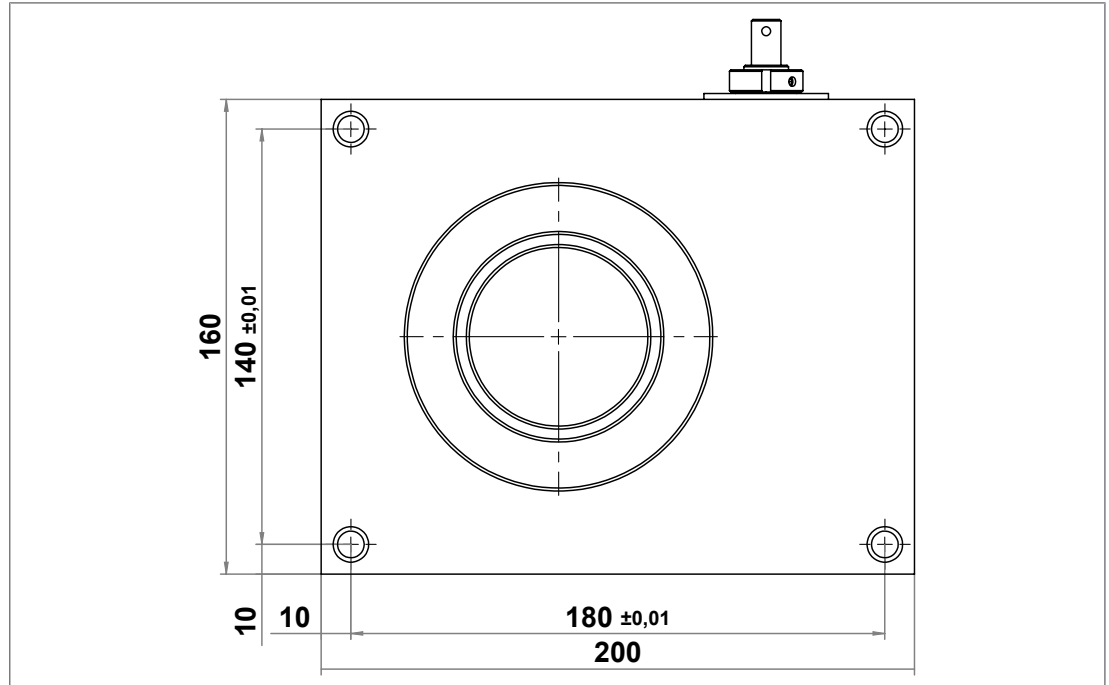
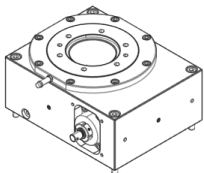

Fig. 3: Dimensions of rotary table

### Technical data of rotary table



Ratio	48:1
Max. input speed [rpm]	2880
Max. output speed [rpm]	60
Max. input torque [Nm]	3
Max. output torque [Nm]	80
Radial run-out accuracy [mm]	± 0.02
Axial run-out accuracy [mm]	± 0.02
Inclined position of the rotary plate [mm]	0.02/100
Backlash [°]	± 0.03
Max. tilting moment [Nm]	350
Max. centric force absorption at standstill [N]	14000
Necessary breakaway torque [Nm]	0.15
Weight (without accessories) [kg]	9.8
Max. external mass moment of inertia with motor (direct, without gear unit) [kg-cm <sup>2</sup> ]	20000
Max. external mass moment of inertia with belt drive 2:1 [kg-cm <sup>2</sup> ]	80000

Tab. 3: Technical data of rotary table

### Environmental conditions

Operating temperature	0–60°C
Change in temperature	maximum 10°C / h
Relative humidity	15–80% indoor, no condensation
Air pressure	(860...1060) hPa
Storage temperature	-20 to + 60°C

Tab. 4: Environmental conditions

## 3.3 Type plate / identification of the product

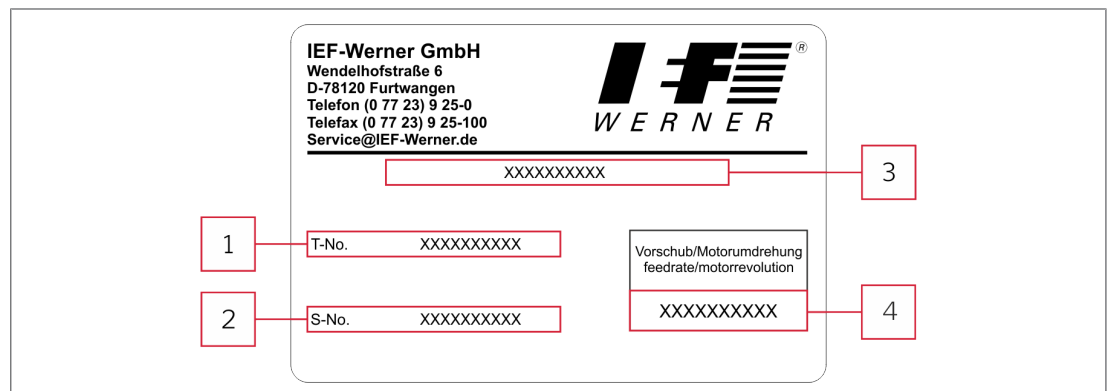

Fig. 4: Type plate (fig. is an example)

1 Part number	2 Serial number
3 Product designation	4 Ratio

## 3.4 Scope of delivery and accessories

Scope of delivery	Required accessories	Optional accessories
<ul style="list-style-type: none"> <li>DT 160/200</li> </ul>	<ul style="list-style-type: none"> <li>Motor</li> <li>Axial flange or belt gear</li> </ul>	<ul style="list-style-type: none"> <li>Reference switch</li> </ul>

Tab. 5: Scope of delivery and accessories

## 4 Transport

### Important notes regarding transport

- Wear suitable protective clothing such as a protective gloves and safety shoes.

### Unpacking

- ▶ Immediately after delivery, check the machine/product for transport damage.
- ▶ Notify the shipping company, insurance company and manufacturer immediately of any transport damage.
- ▶ Leave machine/product unpackaged at room temperature for 24 hours after delivery. This ensures that any condensation present evaporates and all components are at a temperature appropriate for operation.
- ▶ Dispose of packaging in accordance with the requirements applicable nationally.

### Storage

Observe ambient conditions, see Technical data and ambient conditions [▶ 11].

## 5 Installation

### 5.1 Installation accessories (optional)

If the component was ordered with accessories, all accessories are fitted on delivery.

#### 5.1.1 Motor attachment variants

Motors can be mounted either via a belt drive or an axial flange. The following attachment variants are possible:

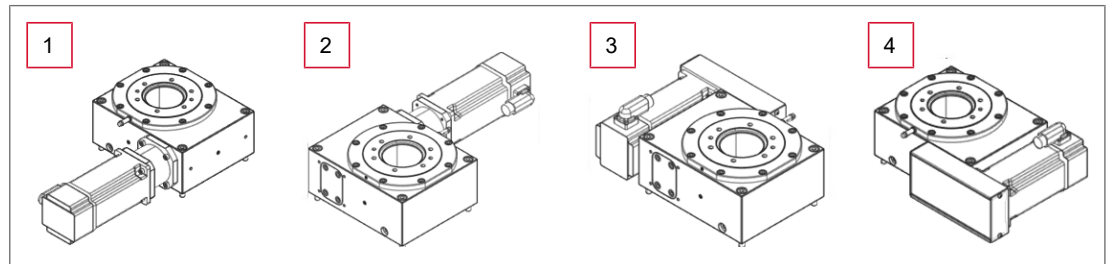

Fig. 5: Motor attachment variants

1 Attachment variant 1, axial

2 Attachment variant 2, axial

3 Attachment variant 1, belt gear

4 Attachment variant 2, belt gear

Drawings of the attachment variants can be downloaded from the homepage.

#### 5.1.2 Motor (axial motor attachment)

##### Technical data of servomotor (IEF-Werner standard) and dimensioning proposal for other motors

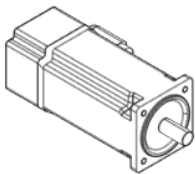

Motor type	permanent-magnet three-phase synchronous motor
Motor rated torque [Nm]	2.2
Motor flange dimension [mm]	72 x 72
Motor shaft [mm]	Ø 14
Motor centring diameter [mm]	Ø 60

Tab. 6: Technical data: Servomotor and dimensioning proposal

##### Axial motor attachment

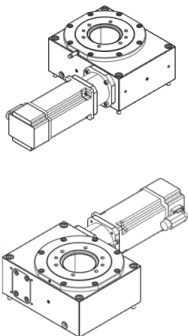

The motor can be mounted via an axial motor flange in the extension of the drive shaft. The maximum motor shaft diameter is 14 mm.

The motor shaft is coupled to the shaft journal using a plug-in coupling (type: EKL10). The motor is centred via the shoulders of the axial flange. Additional pinning of the motor flange to the rotary table is not required.

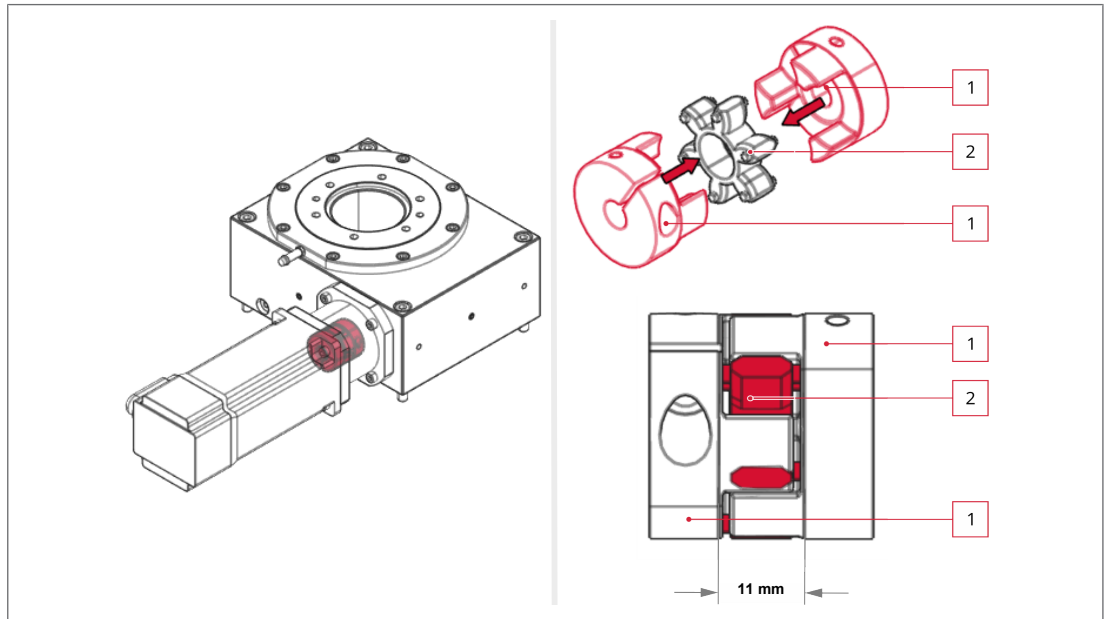

Fig. 6: Mounting coupling

1 Motor or spindle coupling hub      2 Flexible spider

- Grease and assemble the coupling, ensuring that no axial pressure is exerted on the flexible spider and that the assembly dimension (see figure) is observed.

### 5.1.3 Motor with belt gear

#### Technical data of servomotor (IEF-Werner standard) and dimensioning proposal for other motors

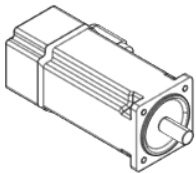

Motor type	permanent-magnet three-phase synchronous motor
Motor rated torque [Nm]	2.2
Motor flange dimension [mm]	72 x 72
Motor shaft [mm]	Ø 14
Motor centring diameter [mm]	Ø 60

Tab. 7: Technical data: Servomotor and dimensioning proposal

#### Technical data of belt gear

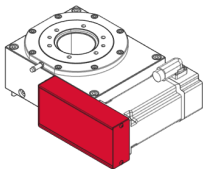

Gear unit: Transmission ratio	2:1
Gear unit: Max. input speed [rpm]	5760
Gear unit: Maximum input torque [Nm]	1.5
Gear unit: Gearing	AT 5

Tab. 8: Technical data: belt gear

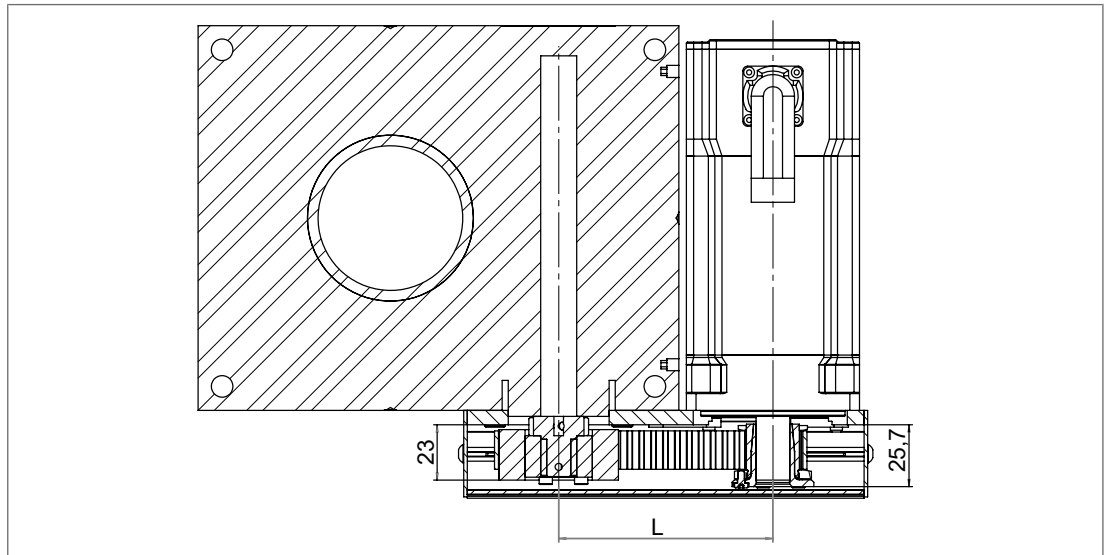

Fig. 7: Belt gear

Gear unit: Transmission ratio	Gear unit: Lock washer Motor [number of teeth]	Gear unit: Lock washer Spindle [number of teeth]	Gear unit: Max. Ø Mo- tor shaft [mm]	Gear unit: Belt length [mm]	Gear unit: Centre dis- tance L [mm]
2:1	16	32	14	300	89

### Motor attachment via belt gear

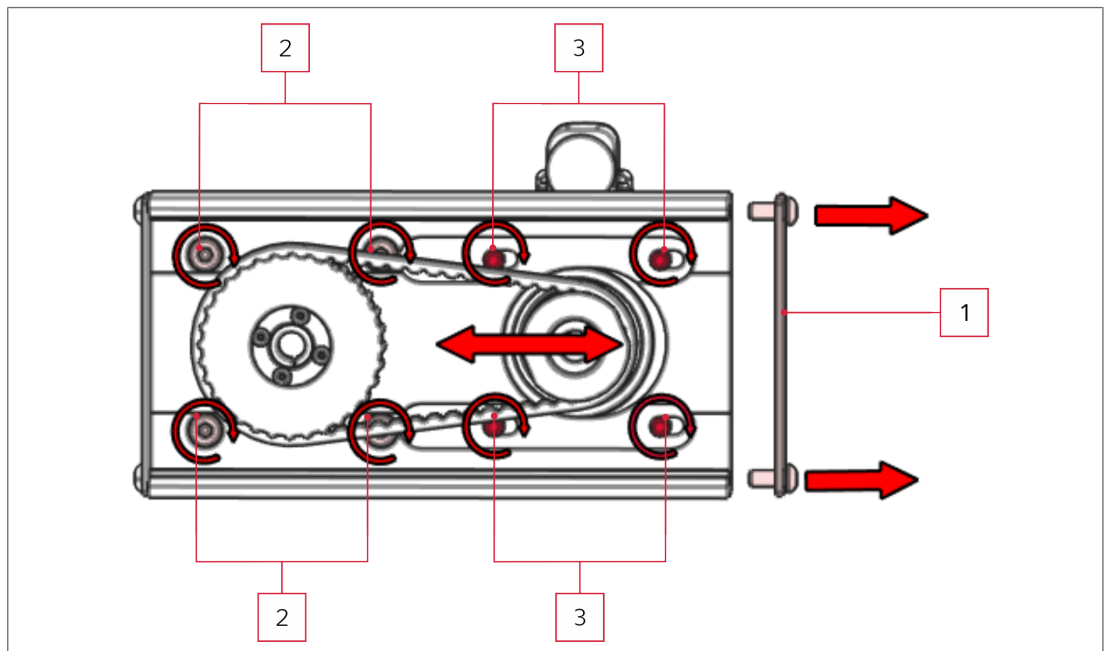
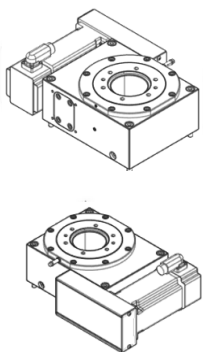

Fig. 8: Belt gear

1 Gear unit housing cover, lateral	2 Gear unit fastening screws (4 x)
3 Motor fastening screws (4 x)	

- ▶ First remove the side and then the front gear unit housing cover.
- ▶ Fasten the belt gear to the rotary table using the gear unit fastening screws.

- ▶ Fasten the motor to the belt gear using the motor fastening screws, do not tighten the screws completely yet.
- ▶ Tension the toothed belt by moving the motor (left/right).
- ▶ Tighten the motor fastening screws.
- ▶ Refit the gear unit housing cover.

## 5.1.4 Reference switch

### Technical data of reference switch

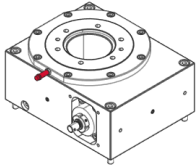

Functional principle	inductive
Repeat accuracy reference point	0.025°
Mounting thread on the rotary table	M5x0.5
Standard output signal	PNP NO contact
Standard plug connection	M8x1-S49

Tab. 9: Technical data: reference switch

The reference switch has the NO contact switching function (switches to free milling).

A reference switch is required for motors with resolvers. The reference switch is optional for motors with multiturn absolute encoders.

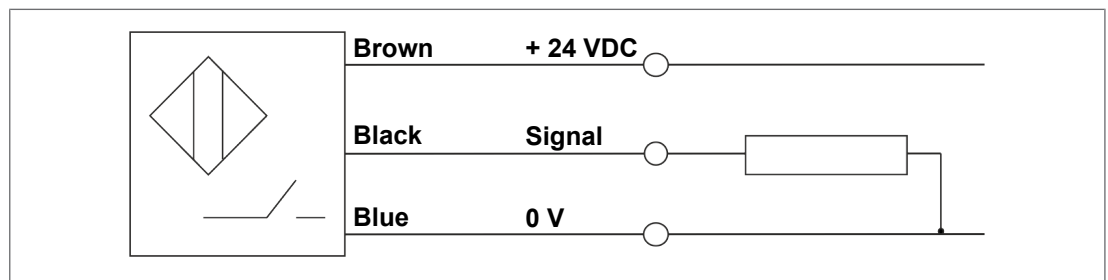
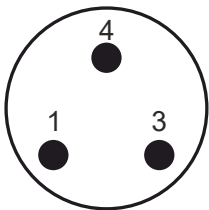

Fig. 9: PNP NO contact: Pin assignment



Pin no.	Assignment	Cable
1	+ 24 V	Brown
3	0 V	Blue
4	Reference point switch	Black

Tab. 10: Pin assignment of the reference switch

### Mounting the reference switch

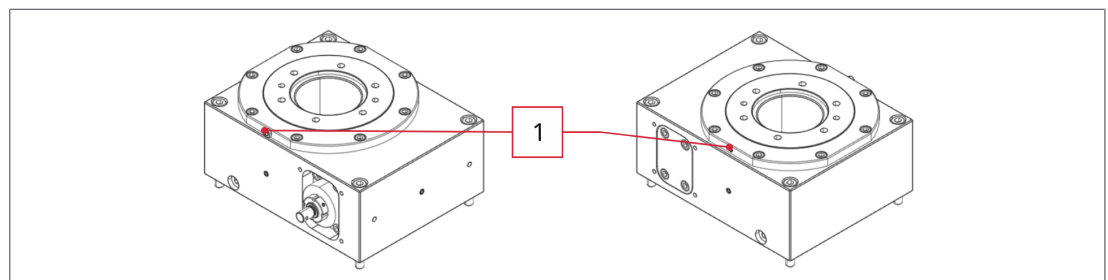

Fig. 10: Mounting the reference switch

- ▶ Remove the grub screw from the fine threaded hole (M5 x 0.5) [1] at the desired position and screw in the reference switch. Screw-in depth: 17 mm (34 revolutions).
- ▶ Secure the reference switch with threadlocker or lock nut.
- ▶ Connect the reference switch to the control electronics according to the pin assignment.

## 5.2 Installation

The following points must be complied with during assembly:

<b>Installation position</b>	Any position (horizontal and vertical) possible.
<b>Flatness of the mounting surface</b>	0.1 mm/m <sup>2</sup>
<b>Further points</b>	<ul style="list-style-type: none"> <li>■ Do not drill any additional holes.</li> <li>■ The component must be mounted without distortion and bending.</li> </ul>



### WARNING

**Risk of injury (crushing, impact)**

**In the case of vertical/inclined installation position, moving parts can move/fall, in an uncontrolled manner, to the final position in the de-energised state.**

- ▶ For vertical installation position, use additional brake and weight compensation if necessary.

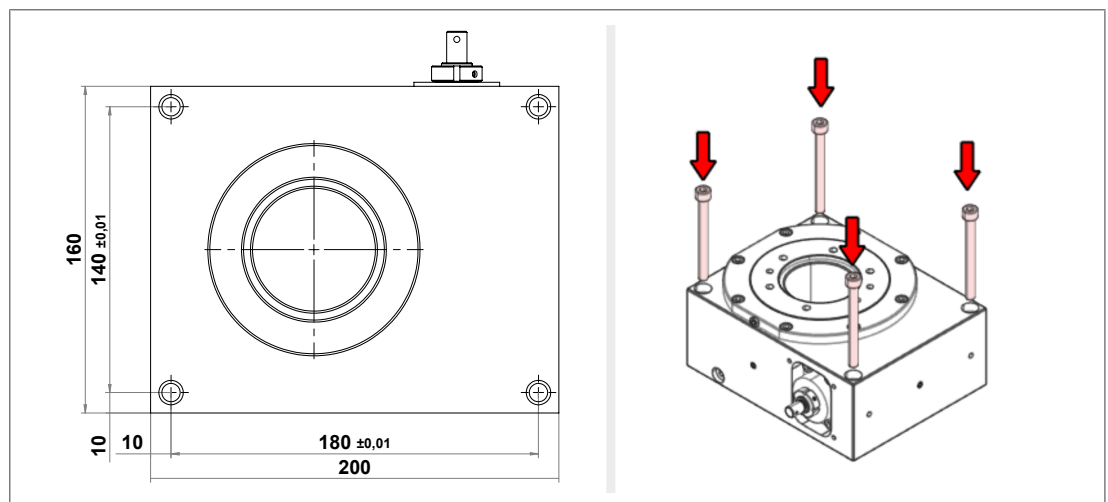

Fig. 11: Fastening the rotary table

- ▶ Fasten the rotary table to a mounting surface using four cheese head screws (M8).

## Mounting the payload on the rotary table

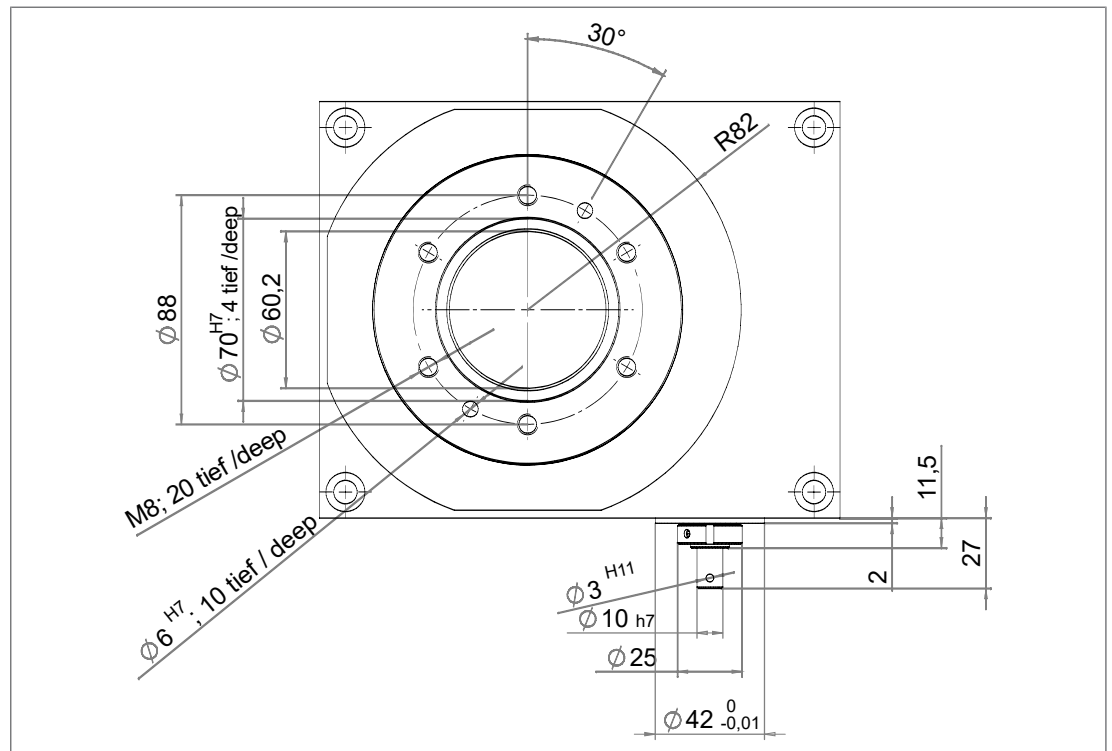

Fig. 12: Drilling pattern

- ▶ Attach payloads to the rotary table according to the holes in the drilling pattern.

## 5.3 Making electrical connection



### **⚠ DANGER**

#### **Risk of death or injury by electric shock**

When connecting a live wire to the machine, touching live, uninsulated parts can result in a fatal electric shock!

- ▶ Work on electrical machine parts may only be carried out by an authorised electrician in accordance with the electrotechnical regulations.
- ▶ Do not remove any covers of live parts.
- ▶ Before starting connection work, switch off all poles of the power supply line in the building and secure it against being switched on again.



### **⚠ CAUTION**

#### **Risk of injury due to improperly laid electrical cables.**

- ▶ Ensure that the bending radius of the electrical cables is maintained.
- ▶ Ensure that the correct cross-section of electrical cables is used.
- ▶ Make sure that the electrical cables are correctly connected to the terminals.

## Connecting the motor

- Notes**
- Only motors that have been approved by IEF-Werner GmbH for the specific application (travel speed, acceleration, load) may be fitted. If you have any questions, please contact the IEF-Werner GmbH service department.
  - Observe motor attachment variants, see Motor attachment variants [▶ 14].
    - ▶ Fasten the motor without tension. Support large/heavy motors.
    - ▶ After installation, connect the motors according to the motor data sheet.

## Mounting the energy chain.

For all moving cables, suitable energy chains must be used to prevent cable breaks.

When mounting the energy chains ensure the following:

- Minimum radius ( $r_{\min}$ ) of energy chains for IEF Werner cables:  
 **$r_{\min} \geq 10 \times \text{cable diameter}$ .**
- Within the energy chain reserve 30% free space.
- Attach strain-relief elements for cable on the output of the energy chain.
- Recommendation: Use cables and energy chains from IEF-Werner.
- If other cables (cables that are not IEF-Werner cables) are used: Comply with EN 60204.

## 6 Commissioning

This incomplete machine is only intended to be installed in or joined together with other (incomplete) machines or equipment in order to form, together with other machines or equipment, a complete machine within the meaning of the Machinery Directive. Only after a conformity assessment procedure, in accordance with the Machinery Directive, has been carried out for the complete machine, may it be put into operation.



### **WARNING**

#### **Risk of crushing due to rotating movement of the rotary plate.**

- ▶ Protect the travel range from being reached into.
- ▶ Keep the travel range free of foreign objects.
- ▶ Install appropriate protective devices (e.g. protective grids).



### **WARNING**

#### **Risk of injury (crushing, impact)**

**In the case of vertical/inclined installation position, moving parts can move/fall, in an uncontrolled manner, to the final position in the de-energised state.**

- ▶ Bring raised, moving parts into final position or fix them, e.g. by means of supports, brakes or belts.



### **CAUTION**

#### **Risk of injury due to rotary movement of the rotary plate.**

Due to the movement of the rotary plate, there is a risk of hair or very thin objects being pulled in/wrapped up

- ▶ Install appropriate protective devices (e.g. protective grids).
- ▶ Without protective device: Wear a hair net if you have longer hair. Do not wear loose or baggy clothing (ties, shirt sleeves) or jewellery.

#### **Before commissioning, check whether:**

- all electrical connections and mechanical connections are carried out according to regulations.
- the protective conductor or protective earthing is properly established.
- contact protection measures are taken for moving and live parts.

## 7 Maintenance

### 7.1 Spare parts and wear parts

Only use faultless, suitable tools and original spare parts or series production parts expressly approved by the manufacturer for repairs. See the supplied lists of spare/replacement parts for information and provision these parts according to requirements and experience.

If necessary, contact our customer service:

IEF-Werner GmbH

Telephone: +49 7723 / 925 - 222, E-mail: service@ief-werner.de

### 7.2 Preparing the product for maintenance tasks

Before maintenance, servicing, disassembly and troubleshooting work, the product must be put into a safe condition.



#### Required qualifications:

Specialist/maintenance technician



#### **⚠ WARNING**

**Serious risk of injury due to electrical voltage.**

- ▶ Before carrying out the following work, de-energise the relevant machine part and secure it against restarting.



#### **⚠ WARNING**

**Risk of injury (crushing, impact)**

**In the case of vertical/inclined installation position, moving parts can move/fall, in an uncontrolled manner, to the final position in the de-energised state.**

- ▶ Bring raised, moving parts into final position or fix them, e.g. by means of supports, brakes or belts.



#### **⚠ CAUTION**

**Risk of burns due to hot surfaces!**

The motor housing and adjacent assemblies can heat up and cause burns when touched.

- ▶ Let motor housing and adjacent assemblies cool down before touching them.

- ▶ the relevant machine part is de-energised and depressurised.
- ▶ Ensure that dangerous machine movements are not possible due to stored energy.
- ▶ Lock all parts that can change their position (product/moving load), e.g. by means of brakes or supports.

## 7.3 Lubricating



### NOTE

#### Danger of material damage!

The maintenance intervals are recommendations that can be shortened by the operating company based on experience gained from maintenance tasks and local conditions.

- ▶ Shorten maintenance intervals if necessary.

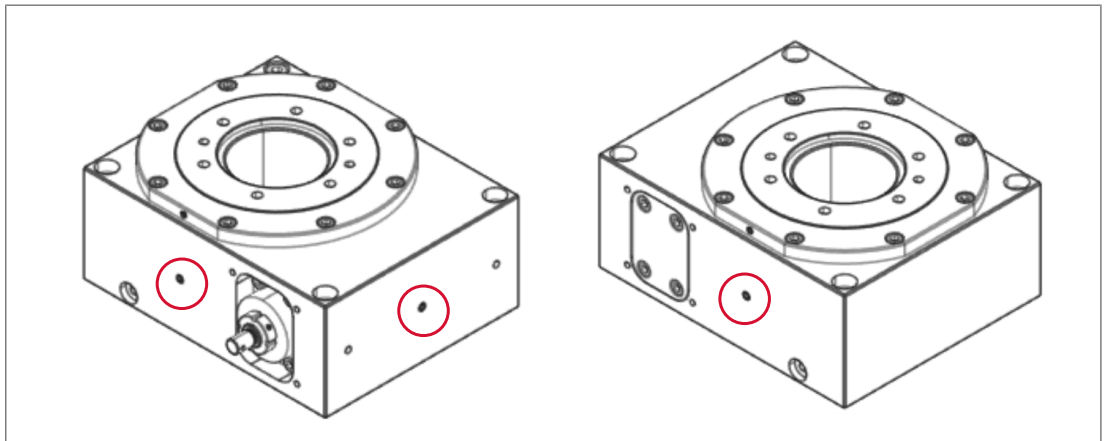

Fig. 13: Lubricating nipple DT 160/200

Module	Lubrication interval	Lubrication quantity per nipple [cm <sup>3</sup> ]	Lubricants and tools *	Lubrication
DT 160/200	400 h	3.5 cm <sup>3</sup> (10 strokes)	Grease gun – Dynalub 510 (part no.: 1315984), refill cartridge 400 g (part no.: 1055014)	Grease one of the grease nipples.

**\* For special requirements:** Observe the label with information on the lubricant on the component. E.g. for food and medical technology: Grease gun – BERULUB FG-H 2SL (part no.: 1315987)

## 7.4 Tensioning the toothed belt (for belt gear)

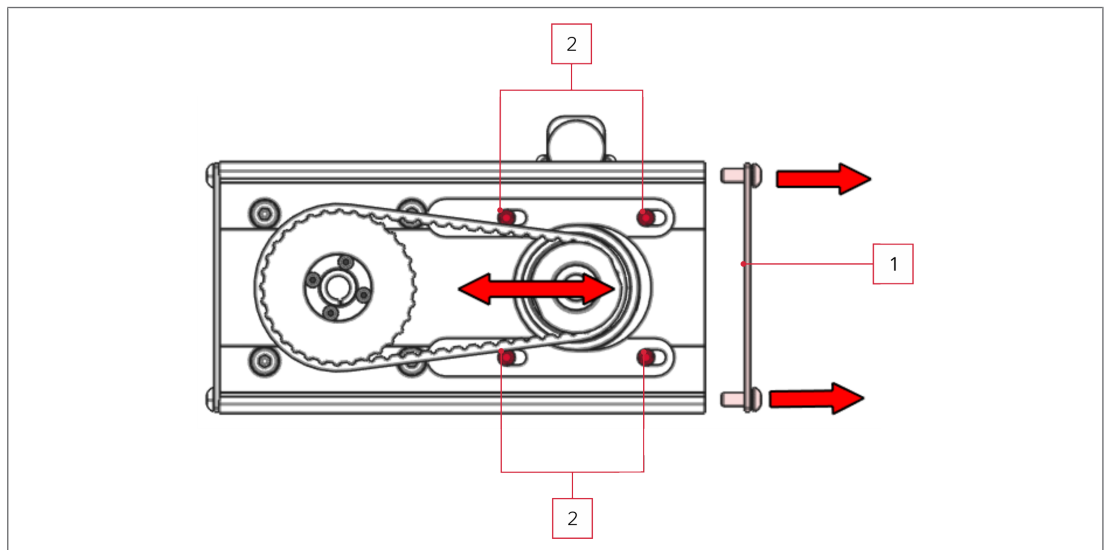

Fig. 14: Gear unit (figure without rotary table)

1 Gear unit housing cover, lateral	2 Motor fastening screws (4 x)
------------------------------------	--------------------------------

- ▶ First remove the side and then the front gear unit housing cover.
- ▶ Loosen the motor fastening screws.
- ▶ Tension the toothed belt by moving the motor (left/right).
- ▶ Tighten the motor fastening screws.
- ▶ Refit the gear unit housing cover.

## 7.5 Adjusting the play of the worm gear

The play adjustment is carried out at the factory. Adjustment may be necessary due to wear of the worm gearing.

The drive shaft (worm) is supported by an axial bearing (fixed bearing) and a ball bearing (bearing support, floating bearing).

### With setting aid

- ✓ Setting aid (article no.:1453589) is available.

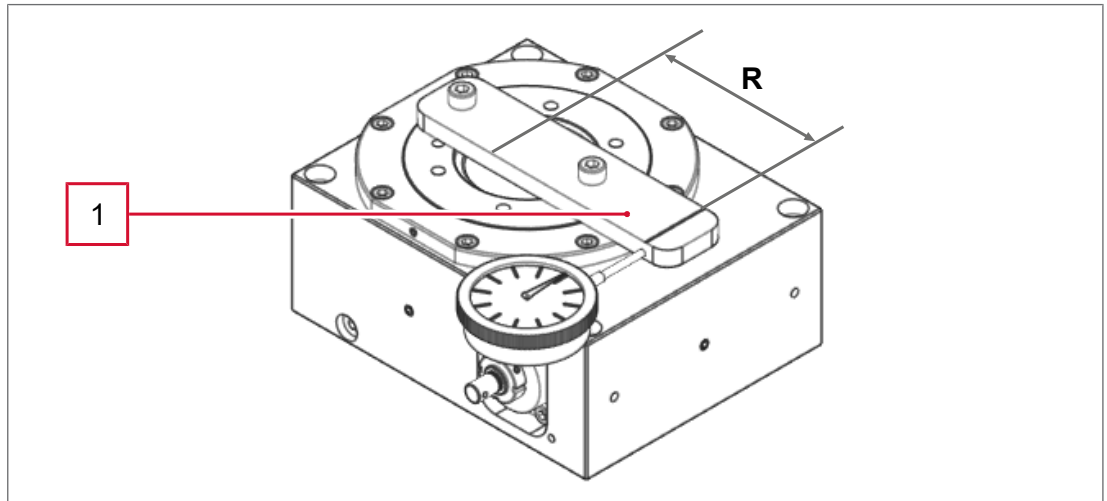

Fig. 15: Backlash adjustment: Setting aid

#### 1 Setting aid

- Set the backlash of the worm gear using the setting aid: The guide value [R] for the backlash/play in the worm gearing is 0.1 mm on a radius of 100 mm (corresponds to 0.057°).

#### Without setting aid

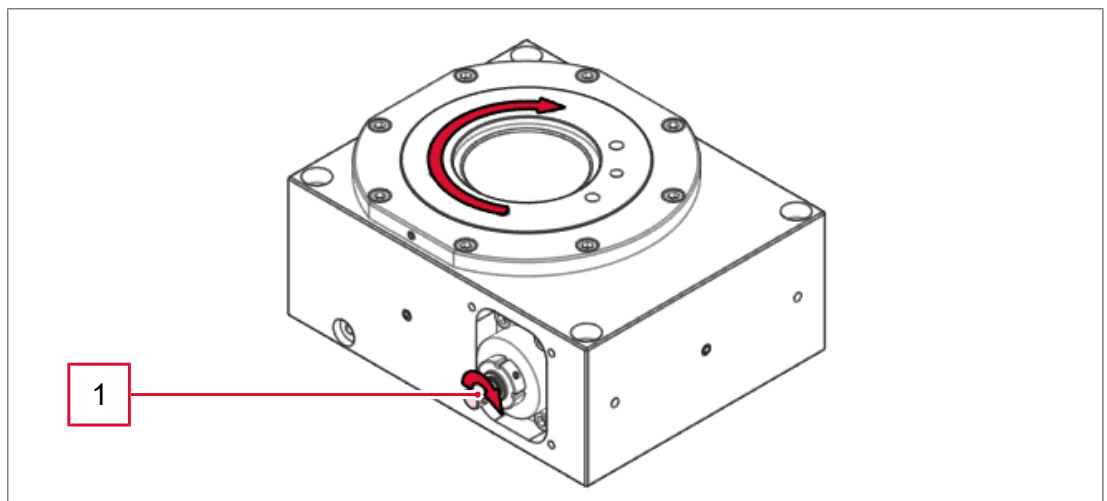

Fig. 16: Backlash: Drive shaft

#### 1 Drive shaft

- Check the current backlash. It serves as a reference.

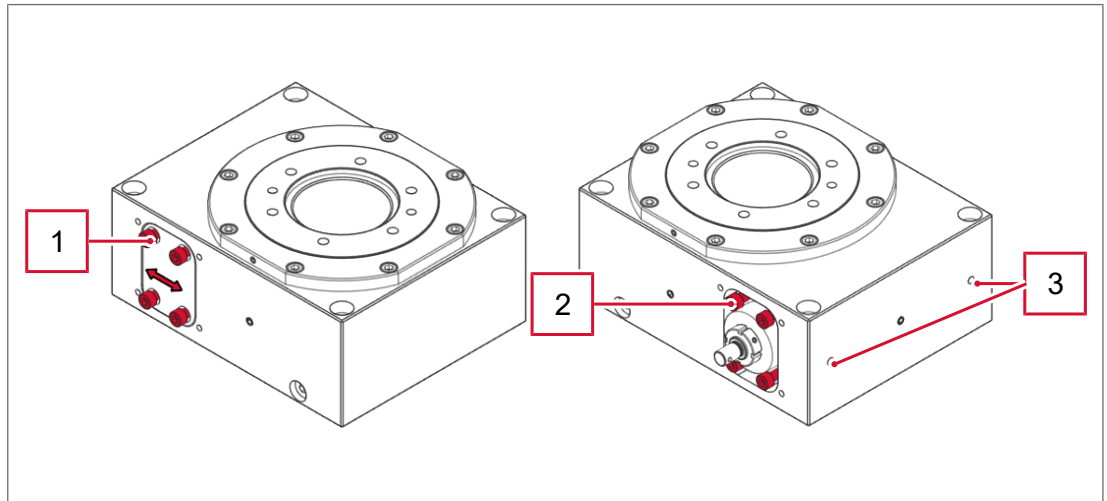

Fig. 17: Backlash: Loosen screws

1 Screws on the bearing mount  
(floating bearing)

2 Screws on the axial bearing

3 Adjusting screws

- ▶ Slightly loosen the screws of the bearing holder and the screws of the axial bearing.
- ▶ Lightly tighten the screws of the axial bearing again.
- ▶ Adjust the backlash only on the locating bearing, on the non-locating bearing side: only tighten the screw.  
Reduce the backlash: Use a hexagon spanner (AF 3) to turn the adjusting screws evenly and only 1/10 of a turn clockwise.  
Increase the backlash: Turn the adjusting screws with a hexagon spanner (AF 3) evenly and only 1/10 of a turn anti-clockwise.
- ▶ Check the backlash several times: the rotary plate should rotate smoothly at least one complete revolution.
- ▶ If the worm gear is jammed:  
Slightly loosen the screws of the axial bearing.  
Turn the adjusting screws anti-clockwise.  
Move the drive shaft.
- ▶ If the backlash is set correctly (minimum): Tighten the screws of the axial bearing and then tighten the screws of the bearing mount.
- ▶ Check that the worm gear runs smoothly for one complete turn of the rotary table.

## 8 Fault rectification

The troubleshooting measures described here are only intended to provide assistance to qualified specialists. Contact the manufacturer's service department, if necessary.

**Exploded-view drawings and parts lists can be downloaded from the homepage.**



### **⚠ WARNING**

**Risk of injury (crushing, impact)**

**In the case of vertical/inclined installation position, moving parts can move/fall, in an uncontrolled manner, to the final position in the de-energised state.**

- ▶ Bring raised, moving parts into final position or fix them, e.g. by means of supports, brakes or belts.



### **⚠ WARNING**

**Serious risk of injury due to electrical voltage.**

- ▶ Before carrying out the following work, de-energise the relevant machine part and secure it against restarting.



### **⚠ CAUTION**

**Risk of burns due to hot surfaces!**

The motor housing and adjacent assemblies can heat up and cause burns when touched.

- ▶ Let motor housing and adjacent assemblies cool down before touching them.
- ▶ Preparing the product for maintenance tasks, see Preparing the product for maintenance tasks [▶ 22].
- ▶ If the components are purchased parts, the documentation of the respective manufacturer (supplier/component documentation) must be complied with before the tasks are carried out.

### Increased running noise

Assembly	Reason	Fault rectification
Worm gear	Runs dry	Grease worm gearing: Grease gun – Dynalub 510 (part no.: 1315984), refill cartridge 400 g (part no.: 1055014).
Worm gear	Backlash setting of the worm gear too large or too small	Adjust the play of the worm gear.
Plug-in coupling (only for axial motor mounting)	Defective	Replace defective coupling.

Increased running noise		
Assembly	Reason	Fault rectification
Toothed belt of the gearbox (only for motor attachment via toothed belt drive)	Defective or running up against the flanges of the lock washer	<ul style="list-style-type: none"> <li>■ If the toothed belt of the gearbox is defective: Replace the gearbox's toothed belt.</li> <li>■ If the flanges of the lock washer are run up against: Align the lock washers.</li> </ul>
Motor	Motor (motor bearing) defective	Comply with the component documentation of the motor manufacturer. Replace motor.
	For motor with brake: Brake does not release	Comply with the component documentation of the motor manufacturer and energise the brake if permissible.

Rotary table does not move		
Assembly	Reason	Fault rectification
Worm gear	Backlash setting of the worm gear too small	Adjust the play of the worm gear.
Power electronics / controller	Fault in the power electronics / controller	Check power electronics / controller.
Motor	Incorrectly connected	Check the pin assignment.
	Motor / motor cable defective	Replace motor / motor cable.
	For motor with brake: Brake does not release	Comply with the component documentation of the motor manufacturer and energise the brake if permissible.

Backlash / position loss		
Assembly	Reason	Fault rectification
Worm gear	Backlash setting of the worm gear too large	Adjust the play of the worm gear.
Storage unit	not tightened	Tighten the screws.
	Defective	Replace the bearing unit.
Motor	Toothed motor pulley has play (feather key connection), friction locking of lock washer clamping set faulty	Contact IEF-Werner GmbH Service.
Toothed belt of the gear unit	Not tensioned	Tension the gear unit toothed belt.

## 9 Dismantling and disposal



### **WARNING**

**Serious risk of injury due to electrical voltage, hot surfaces and unpredictable movements.**

The work described below is not part of normal operation. Therefore, the product must first be put into a safe state (maintenance state):

- ▶ Preparing the product for maintenance tasks, see Preparing the product for maintenance tasks [▶ 22].
- ▶ Remove electrical installations.
- ▶ Remove the motor and attachment kit.
- ▶ Remove the fastening elements.

### **Disposal**

The disposal of all replacement parts and in particular the operating materials used, such as lubricants or other environmentally hazardous substances, such as electronic scrap or batteries, must be carried out by specialist companies in accordance with the applicable statutory regulations.

The product and packaging must be recycled in an environmentally friendly manner in accordance with the applicable regulations.





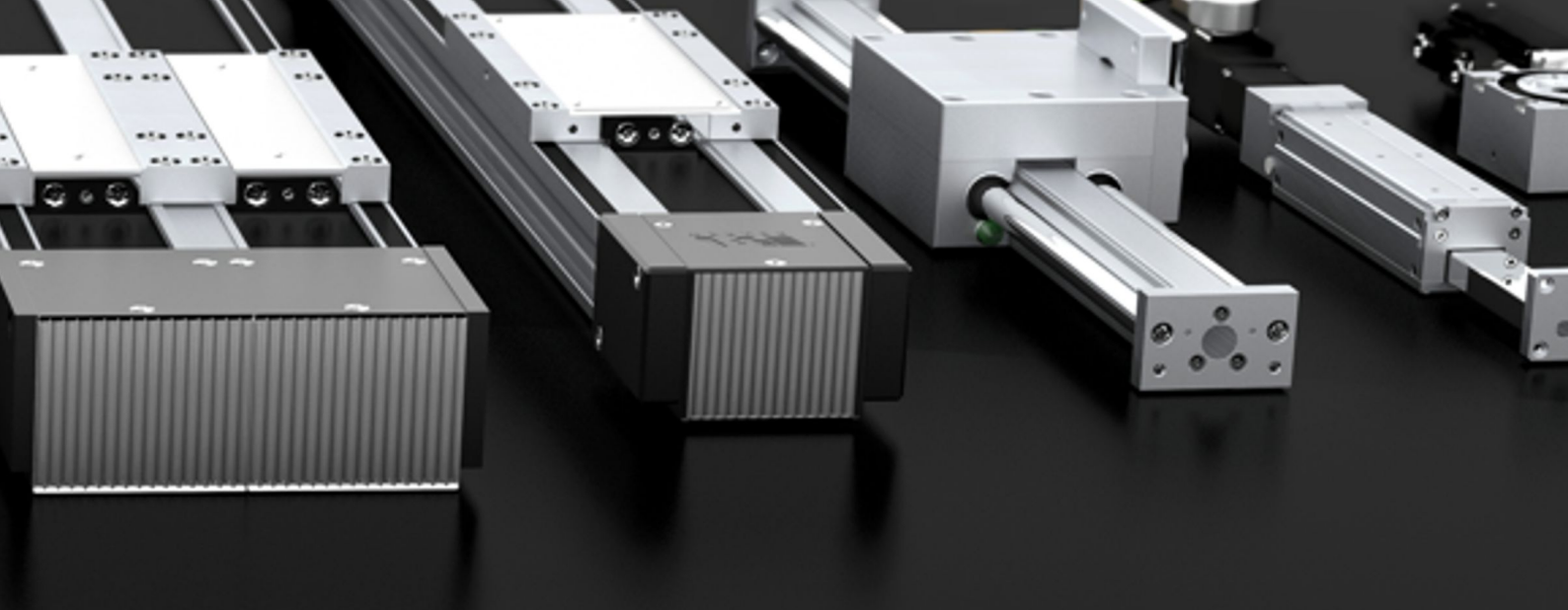

IEF-Werner GmbH  
Wendelhofstraße 6  
Germany-78120 Furtwangen  
Telephone: +49 7723-925-0  
info@ief-werner.de