

Mounting instructions (Translation)

Module easyLINE

Issue: October 2019

Article no.: 1040582

IEF-Werner GmbH
Wendelhofstraße 6
78120 Furtwangen - Germany
Phone: +49 7723-925-0
Fax: +49 7723-925-100
www.ief.de
info@ief-werner.de

Change History:

Document Code	Date	Revision
MAN_EN_1040582_easyLINE_R2b.doc	26.02.2007	Release of the English Document ("MAN_EN_1040582_easyLINE_R2b.doc").
MAN_EN_1040582_easyLINE_R3a.doc	13.06.2013	Document updated regarding the new machinery directive (MRL 2006/42/EC). Made from German document "MAN_DE_1040581_easyLINE_R3a.doc".
MAN_EN_1040582_easyLINE_R3b.doc	21.10.2019	Standards updated in the Declaration of incorporation.

Trademarks and trade names are used without any warranty of their free usability. Texts and examples were created with great care. Nevertheless, errors cannot be excluded. IEF-Werner GmbH does not assume legal responsibility nor any liability for missing or incorrect statements and their consequences.

IEF-Werner GmbH reserves the right to modify or improve the software or hardware or parts of it, as well as the supplied documentation or parts of it, without previous notice.

IEF-Werner GmbH expressly reserves all rights for replication and photomechanical reproduction, including in extracts.

We are always grateful for suggestions for improvements and information about errors.

© October 2019, IEF-Werner GmbH

Table of Contents

1	Safety	5
1.1	Definition or warning notes	5
1.2	General warning notes	5
1.3	Special hazard warnings	6
2	Intended use	7
2.1	Reasonably foreseeable misuse	7
3	Assembly instructions	8
3.1	Installation position	8
3.2	Overview of motor installation variants	8
3.2.1	Installation variant 1	9
3.2.2	Installation variant 5	9
3.3	Attachment	10
3.3.1	Mounting with clamping elements	10
3.3.2	Attachment at the carriage of the linear module	12
3.3.3	Installation of actuators	13
3.4	Wiring	14
3.4.1	Motors	14
3.4.2	Initiators	14
3.4.2.1	Plug end position switch	16
3.4.3	Cable routing	16
3.5	Technical data	17
3.5.1	Tightening torques for screw connections	17
3.5.2	Technical Data of easyLINE module	17
3.5.4	Technical data when using a planetary gear	18
3.5.5	Load cases	19
3.5.5.1	Torques and load carrying capacity	19
4	Maintenance	20
5	Trouble shooting	21
6	Repair instructions	23
6.1	Toothed belt tension	23
6.2	Belt tension gear toothed belt	23
7	Parts lists and drawings	24

7.1	easyLINE installation variant 1	24
7.2	Reversing unit easyLINE (Article.No. 526261)	26
7.3	Carriage easyLINE completed (Article no. 526311)	27
7.4	Long carriage easyLINE complete (Article no. 526609)	28
7.5	Gearbox (Subassembly no. 1000002)	29
7.6	Flange $i = 1:1$ (Subassembly no. 1000003)	30
7.7	easyLINE clamping block complete – exploded view (Article no. 526262)	31
7.8	easyLINE long carriage clamping block complete - exploded view (Article no. 526610)	32
7.9	easyLINE, parallel drive – exploded view	33
8	Declaration of incorporation	34

1 Safety

1.1 Definition or warning notes



WARNING

Indicates potential danger. Non-observance of the safety provisions may cause death or severe injury.



CAUTION

Indicates potential danger. Non-observance of the safety provisions may cause property damage or injury.

NOTE Offers additional information.

1.2 General warning notes

The module must only be commissioned by specialists who received safety-technical instruction and are able to assess potential dangers. Furthermore, all chapters of these operating instructions must have been read and understood completely.



WARNING

The system must be powered down for all assembly, disassembly or repair work. There is a high danger of injury.



WARNING OF HOT SURFACE

During operation, heating of the motor, in particular of stepper motors, can cause burns of the skin when touching the motor. Install a protective device, if possible! Do not touch the marked areas or wait for an adequate cooling time.



CAUTION

Motor connectors must not be inserted or disconnected when live. Risk of burning of the contacts and risk of flying sparks.



CAUTION

Linear modules always have to be operated in connection with suitable safety devices (e.g., safety cell, protective room, protective housing, light curtain).

NOTE

Observe the Manufacturer's Declaration (see section *Declaration of incorporation*, page 34).

1.3 Special hazard warnings

In addition, this operating instructions also contains the following special hazard warning:



DANGER FROM CRUSHING

These places of the components pose the danger of crushing limbs in operation.

2 Intended use

The easyLINE module (see *Figure 1*) is a precise, linear adjustment unit with toothed belt drive that is used in the commercial area as an attachment part in connection with other components. In combination with many standardised installation elements and the other linear modules of IEF-Werner GmbH (e.g. module 68 and 68D, module 105, module 105 S, module 142 and module 142 S), complex multi-axis handling systems can be developed as well.

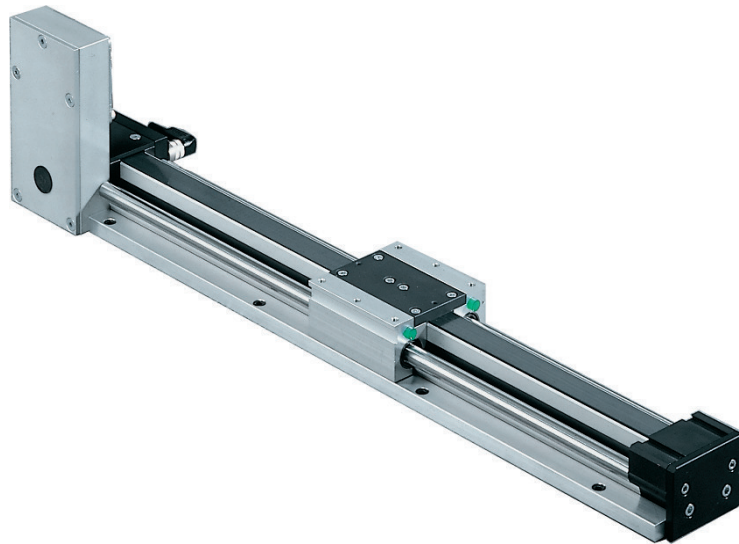

Figure 1: easyLINE module

The areas of application of an easyLINE module are accordingly diverse.

They encompass:

- Stop adjustment in the wood industry
- Equipment systems for SMD components
- Joining and press-in processes in precision mechanics
- Loading and unloading station of tool machines up to
- Manipulators for the packaging industry

2.1 Reasonably foreseeable misuse

The easyLINE module is **not** to be used for certain applications, and in particular not for such as the transport of persons and animals or as a pressing/bending device for cold working of metal.

Use of the linear module without additional measures is also **not** possible in special fields of application, such as the chemical or food industry or in explosive atmospheres.

In case of doubt, consult the manufacturer.

3 Assembly instructions

3.1 Installation position

The installation position is optional, i.e. the easyLINE module can be used horizontally as well as vertically.



CAUTION

In the vertical installation position, use only motors with spring-operated brake to prevent the lowering of the drive in de-energized condition!

3.2 Overview of motor installation variants

The generally variants of installation are (see *Figure 2*):

Installation variant 1

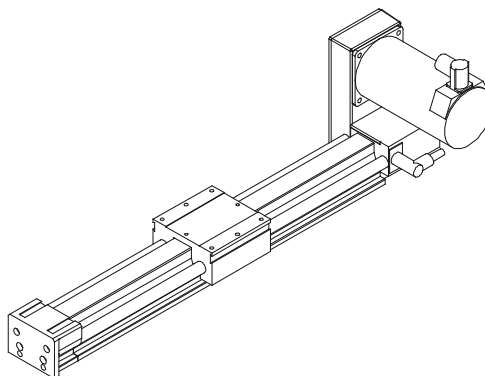

Installation variant 5

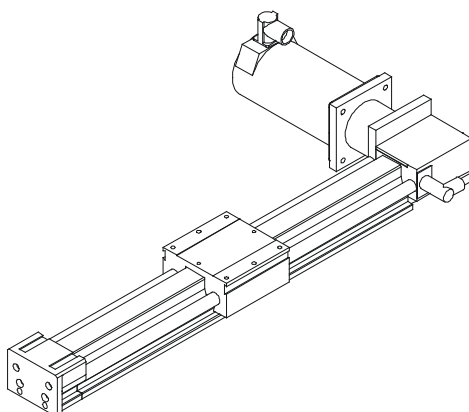

Figure 2: Installation variants easyLINE module

3.2.1 Installation variant 1

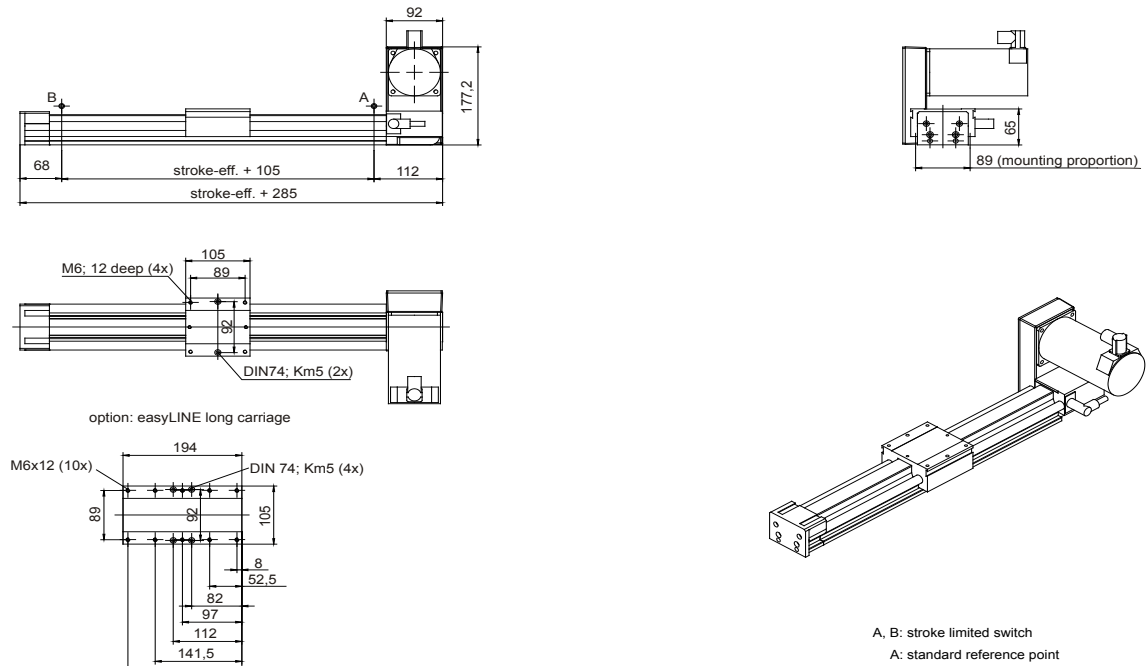

Figure 3: easyLINE installation variant 1

3.2.2 Installation variant 5

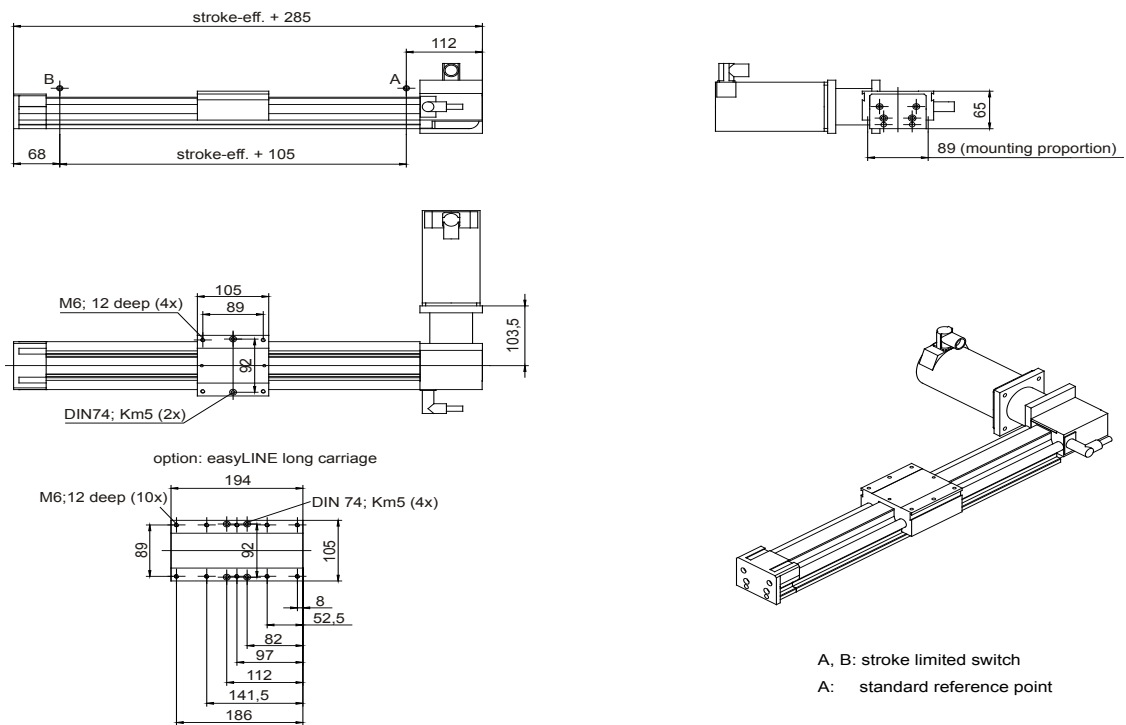

Figure 4: easyLINE installation variant 5

3.3 Attachment

3.3.1 Mounting with clamping elements

The use of clamping elements (see *Figure 6*) allows the linear unit easyLINE to be easily secured to a level mounting surface. Standard length clamping elements are available for the cross-mounting of linear units. For safety reasons, continuous clamping sections are advised. This ensures hazardous shear points are avoided.

Please avoid additional drilling holes in the basic body. This might damage the internal parts of the linear unit and could distort the guide base.



CAUTION

The clamping area should have a planeness of 0.1 mm/m²

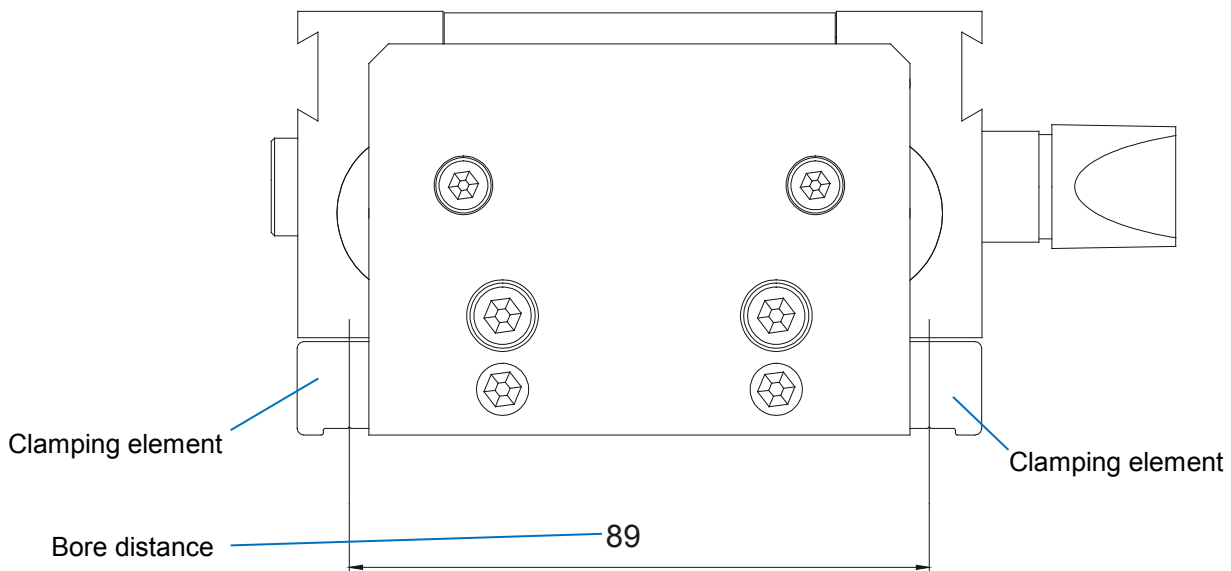

Figure 5: Attachment with clamping elements

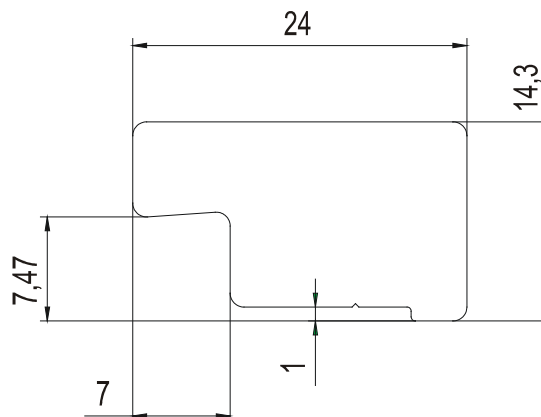

Figure 6: Dimensions clamping element



CAUTION

Observe the hazard points shown in *Figure 7* and *Figure 8* !

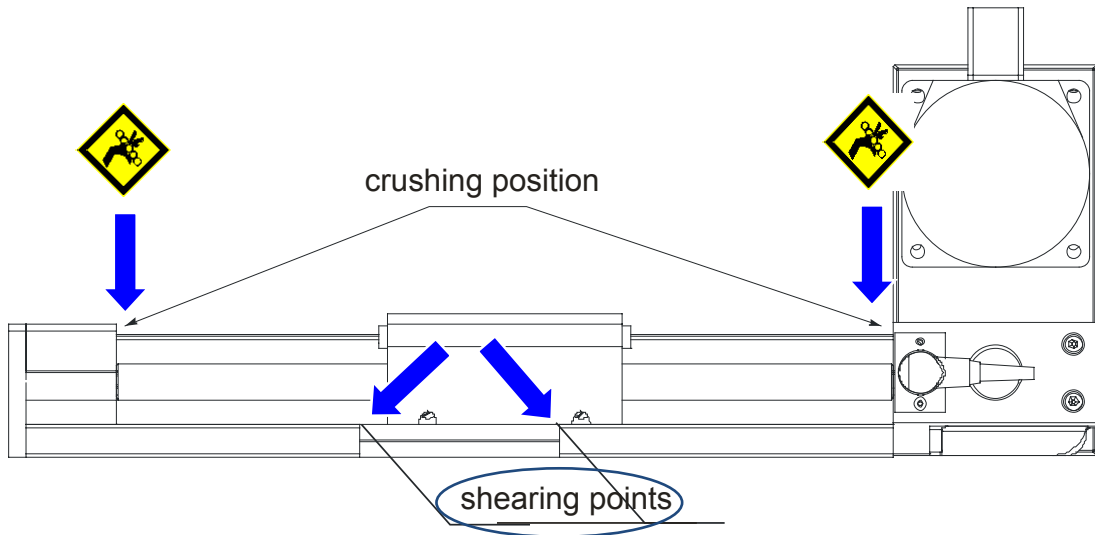

Figure 7: Attachment with standard-clamping elements

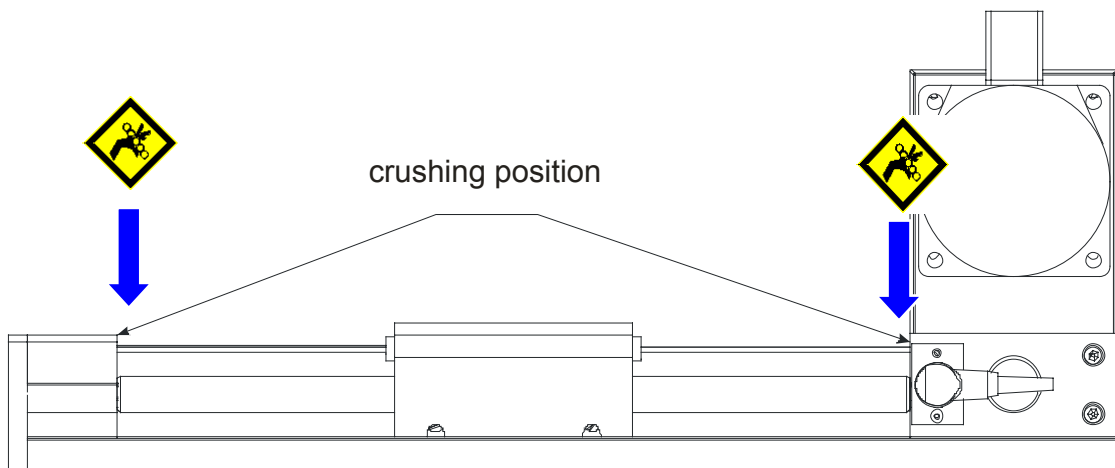

Figure 8: Attachment with continuously clamping elements (no shearing points)

3.3.2 Attachment at the carriage of the linear module

As a second possibility the linear module can be attached at its carriage (use easyLINE with a long carriage and a stroke longer than 300 mm).

The basic body moves free. However, in this case the motor, motor cable, limit switch cable and also encoder or resolver cable have to be moved as well.

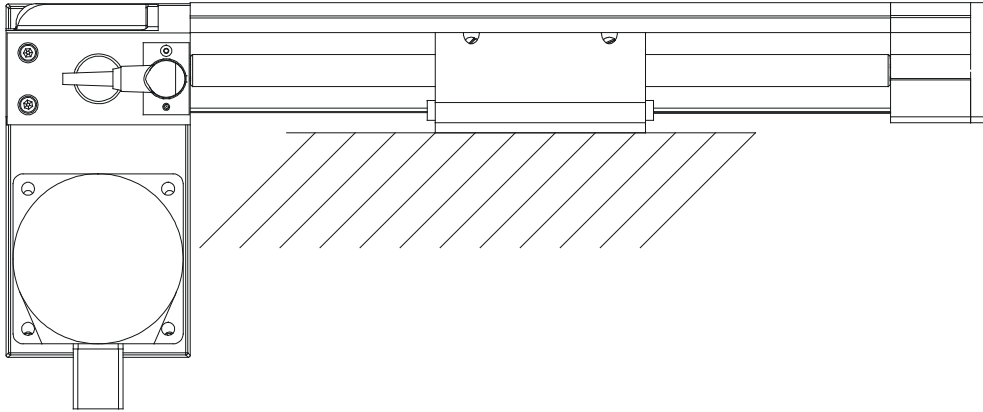

Figure 9: Mounting example

Via two borings M5 (see ① in *Figure 10*) the linear unit can be tighten up on a mounting table. A further mounting possibility is using the 4 threaded borings M6 (see ②) possibly through a distance plate.

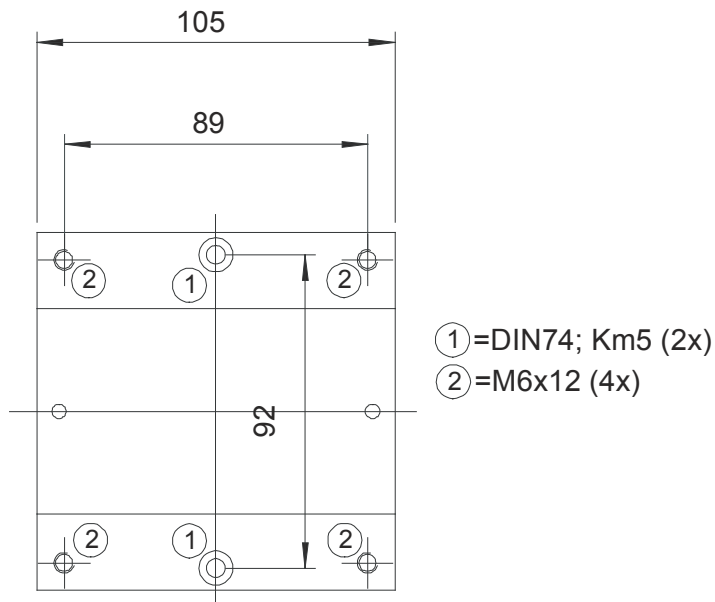

Figure 10: Mounting detail standard slide

Both attachment variants are possible. The respective application determines the needed variant (long side, see *Figure 11*, page 13).

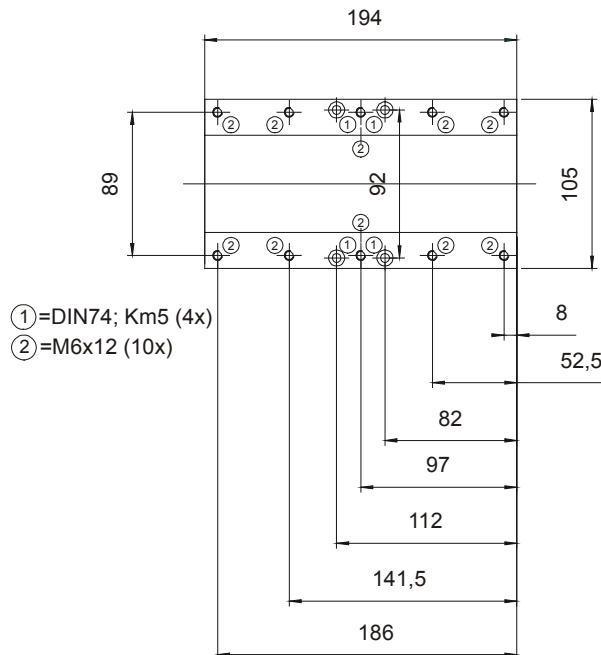

Figure 11: Mounting detail long slide

3.3.3 Installation of actuators

Actuators (pick-up modules, cylinders etc.) to be installed on the module easyLINE are usually attached to the linear unit using the drill template of the end plates, see *Figure 10*, page 12 or *Figure 11*, above.

If you assemble according to *Figure 9*, page 12, you can mount the actuators according to the mounting example of *Figure 12*, below.

Only very light elements (less than 1 kg) can be attached directly on the end plate. In this case, you should equip the end plate with a suitable mounting plate.

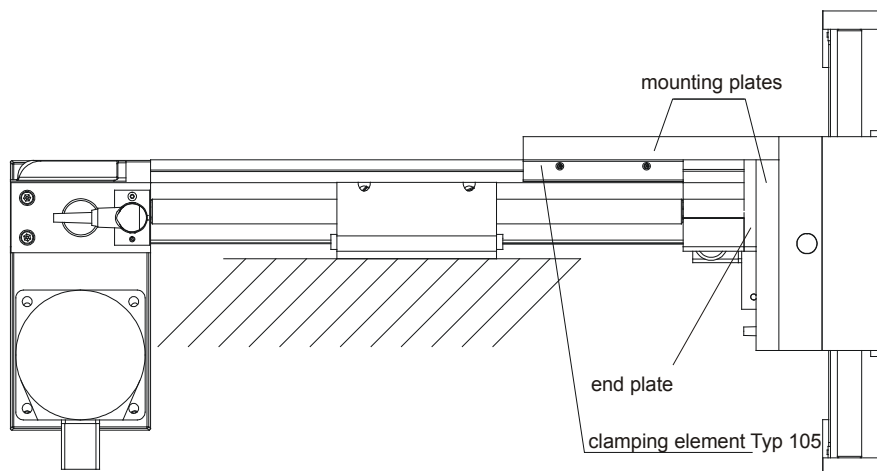

Figure 12: Mounting example

3.4 Wiring

3.4.1 Motors



CAUTION

The electrical connection of the motors is performed according to the motor data sheet. For customer-specific motors, the data sheet must be requested from the respective manufacturer and the motor connected accordingly.

3.4.2 Initiators

Inductive proximity switches (PNP normally closed contacts, article no.: 025165 see *Figure 14*) are used as standard limit switches for the running path. These switches are no safety limit switches pursuant to EN60204-1. Optionally, (also subsequently) an additional reference point switch (PNP normally open contact article no.: 726744, see *Figure 13*), can be installed in the easyLINE module. The active button is marked with a coloured circle. Normally closed contacts are marked with a green, normally open contacts with a red dot. The initiators and their supply lines are protected in a cable channel integrated in the basic body and are wired to a joint plug.

A plastic strip serves to cover the cable channel. An initiator can be replaced or relocated easily after removal of this plastic strip from the cable channel.

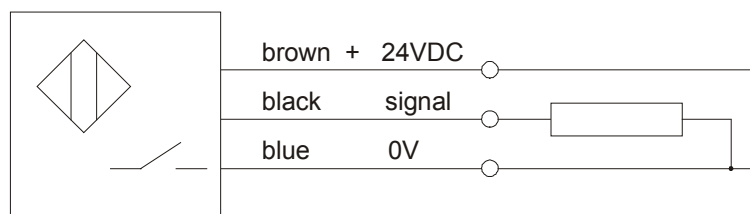

Figure 13: Connection allocation PNP normally open contact

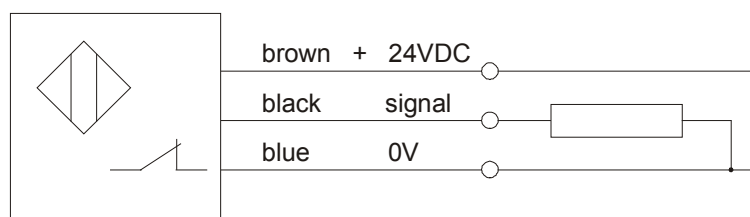

Figure 14: Connection allocation PNP normally closed contact

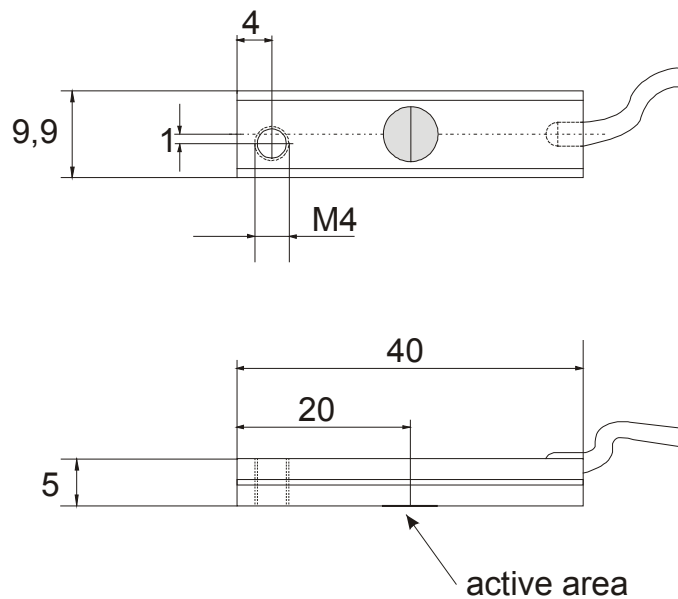

Figure 15: Dimensions initiator

Technical data of initiators

Parameter	Value
Operating voltage, incl. residual ripple	10...30 VDC \leq 15 %
Current load capacity	$I_a \leq$ 200 mA
Switching frequency	\leq 1000 Hz
Consume current	\leq 15 mA
Nominal switch distance at steel	1.5 mm \pm 10 %
Switching hysteresis	(3...20) %
Reproducibility (U = konst.)	\pm 0.1 mm
Operating temperature	- 25 ° ... + 70 °C
Protection class	IP 65
Short-circuit proof	yes
Reverse battery protection	yes

Figure 16: Technical data of initiators

3.4.2.1 Plug end position switch

The end position switch is assigned as follows (see *Figure 17*)

Pin-No.	Assignment	IEF-Werner cables
1	+ 24 V	brown
2	Limit switch negative direction	green
3	0 V	white
4	Limit switch positive direction	yellow
5	Reference switch	grey

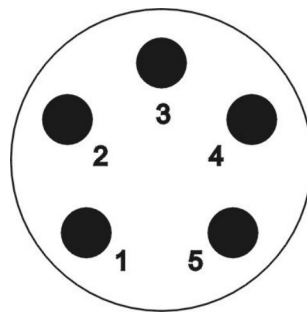

Figure 17: Connection assignment plug end position switch

3.4.3 Cable routing

For all moving cables, suitable cable routing has to be used to effectively prevent cable breaks.

The minimum radius r_{\min} for cable carriers results from the following formula:

$$r_{\min} \geq 10 \times \text{cable diameter}$$

When different cables are used, EN 60204 must be observed. In addition, it must be ensured that a space reserve of 30% is kept free within the routing chains. A strain relief for the cables has to be attached at the outlet of the cable routing chain.

We recommend procuring original cables and cable routing chains from IEF-Werner. Please contact us, we will be pleased to provide advice.

3.5 Technical data

3.5.1 Tightening torques for screw connections

Screw 8.8	Tightening torque [Nm]
M3	1.1
M4	2.5
M5	5.0
M6	8.5
M8	21.0
M10	41.0
M12	71.0
Screw 12.9	Tightening torque [Nm]
M4 (fixation of guiding rail)	4.9

3.5.2 Technical Data of easyLINE module

Parameter	Value
Repeating accuracy	+/- 0.04 mm
Weight (without motor, without planetary gearbox) at stroke 0 mm	4.4 kg
Weight increase per 100 mm stroke	0.7 kg
Maximum speed	2.5 m/s
Torque Mx	35 Nm
Torque My	50 Nm
Torque Mz	20 Nm
Static load carrying capacity C1	1000 N
Static load carrying capacity C2	550 N

3.5.3 Type label

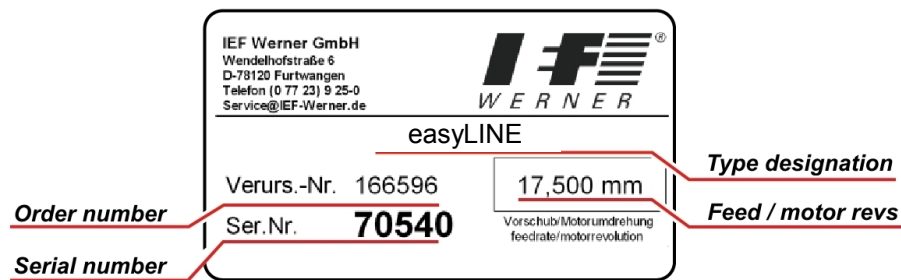

Figure 18: Type label (example)

3.5.4 Technical data when using a planetary gear

Before commissioning, observe the possible input speeds of the gear manufacturers. Too-high input speeds can lead to increased wear at the gear and/or thermal problems.

The accuracy of the linear unit is influenced by the reverse play of the gears.

Example:

The gear reverse play (S) is 9 angle minutes.

How high is the reverse play at the carriage of the linear unit?

Infeed constant of the linear unit (Vk): 140 mm

$$\begin{aligned}
 \text{Reverse play at the carriage} &= (V_k \cdot S) / (360 \times 60) \\
 &= (140 \text{ mm} \cdot 9) / (360 \times 60) \\
 &= 0.058 \text{ mm}
 \end{aligned}$$

Consider the information of the respective gear manufacturer in any case.

e.g. <http://www.neugart.de/index.php/gb/Produkte/Standardgetriebe>

<http://www.wittenstein-alpha.de/en/drive-systems.html>

3.5.5 Load cases

3.5.5.1 Torques and load carrying capacity

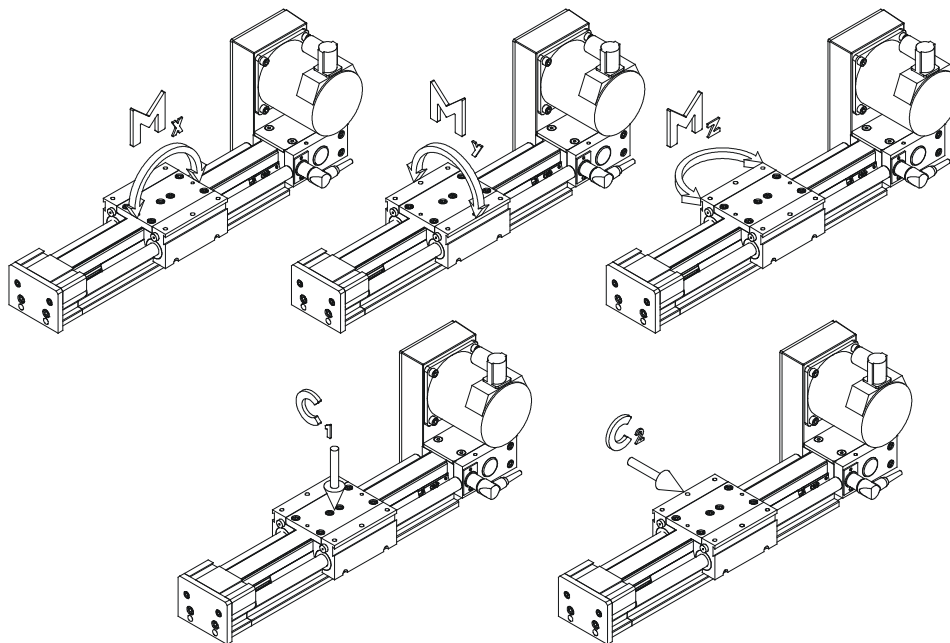

Figure 19: easyLINE load capacity

Extract of technical data (see chapter of *Technical Data of easyLINE*, page 17)

Parameter	Value
Maximum torque M_x	35 Nm
Maximum torque M_y	50 Nm
Maximum torque M_z	20 Nm
Static load carrying capacity C1	1000 N
Static load carrying capacity C2	550 N

4 Maintenance

During the design of the linear unit easyLINE, great importance was placed on the use of low-maintenance components. All roller elements were provided with lifetime lubrication in the factory.

To avoid danger of over-lubrication of the linear bearings, no external lubrication nipples were attached to the carriage part. However, to achieve a high service life of the wipers, we recommend moistening the guide shafts with special grease at regular intervals. The lubricant may be procured from IEF in tubes of 50 gr (Art. no.732934) each:

The recommended maintenance intervals add up to approx. 200 operating hours under regular ambience conditions. The maintenance intervals should be reduced for unfavourable ambient conditions.

5 Trouble shooting

Interference	Reason	Correction
Increased running noise	Nominal service life of linear bearings is exceeded	Replace all linear bearings
	Linear bearings worn from overload (too-high torque, etc.)	Replace all linear bearings, reduce load
	Linear bearings worn of strong contamination	Replace all linear bearings, clean guide elements more often if required
	Guide shafts worn	Replace guide shafts, replace linear bearings if required, check load, protect linear module from strong contamination
	Guide shafts corroded	Replace guide shafts, replace linear bearings if required, lubricate guide shafts more often
	Reversing unit worn	Replace reversing unit
	Drive unit worn	Replace drive unit
	Toothed belt runs dry	Slightly lubricate toothed belt on the toothed side
	Toothed belt tension too high	Install reconciled spacer sleeves
	Toothed belt doesn't move straight	Align toothed belt with belt fastener (carriage plate and tappet), install reconciled spacer sleeves
	Toothed belt strongly contaminated on toothed inner side	Replace toothed belt, protect linear module from strong contamination
	Toothed belt defective	Replace toothed belt
	Motor (motor bearing) defective	Replace motor
	Motor with brake, brake does not open	Apply current to the brake, if the brake still does not open, replace motor
The linear module doesn't move	Limit switch cable not connected	Connect the cable
	Limit switch defective	Change initiator
	Limit switch cable defective	Check limit switch cable, replace cable, if required
	Solder connection on socket has come lose	Solder on wires
	Motor connection incorrectly	Check and change connector assignment, if required
	Motor defective	Replace motor
	Error in power electronics or control unit	Check power electronics or control unit
	motor cable defective	Check motor cable, replace cable, if required

Trouble shooting continuation:

Interference	Reason	Correction
Play on reversal	Toothed gear belt not tensioned	Tension toothed gear belt
	Toothed motor pulley wheel has clearance (keyway)	Replace the toothed motor washer, replace the motor if the keyway of the motor shaft is damaged
	Toothed drive belt not tensioned	Pull the reversing unit back towards it's limit stop (spacer bushing)
Linear drive unit moves mechanically against the stop during the reference run	Incorrect direction of rotation	Change motor direction of radiation
	Broken motor cable	Replace cable

6 Repair instructions



WARNING

Always power down the system before starting repairs.



WARNING

Any repairs must only be performed by specialist personnel who have read and understood the operating instructions.



CAUTION

Only use original replacement parts, otherwise IEF-Werner GmbH will not accept any warranty.

6.1 Toothed belt tension

The toothed belt tension for easyLINE is set with spacer sleeves.
(see drawing item 40 in *Figure 21*, page 26)

6.2 Belt tension gear toothed belt

The belt tension of the gear toothed belt should be 150 N. (see drawing item 10 in *Figure 24* page 29)

7 Parts lists and drawings

7.1 easyLINE installation variant 1

Drawing Pos.	Article no.	Part (1) / subassembly (0)	Usage	Designation
	1000003	0	+	Flange
	525929	1	+	Coupling (only for parallel drive, <i>see chap. 7.9</i>)
	730889	1	+	Aluminium tube (only for parallel drive, <i>see chap. 7.9, page 33</i>)
10	1000002	0	+	Gearbox
20	1000041	0	+	Motor
30	526637	1	+	Drive unit easyLINE two shafts (only for parallel drive <i>see chap 7.9, page 33</i>)
30	526260	1	+	Drive unit easyLINE parallel drive (only for parallel drive <i>see chap 7.9, page 33</i>)
30	526259	1	+	Drive unit easyLINE
40	030312	1		Cover plate easyLINE
50	030342	1		Housing easyLINE
60	028689	1	+	Cover plate easyLINE
60	030431	1	+	Plastic cover easyLINE (<i>chap 7.9, page 33</i>)
70	732284	1		Plastic cover D=25/20.5 black
80	725164	1		Plug WKV 50/6
100	725163	1		Socket plug SFV 50/6
110	025626	1		Holding plate
120	1000009	0		Basic unit easyLINE
130	025165	1		Limit switch PNP-NC
130	726744	1	+	Limit switch PNP-NO
130	627085	1		Headless screw
130	028585	1		Limited switch holder
140	028668	1		Plastic clip
150	028688	1		Cover strip
160	526261	1		Reversing unit easyLINE
170	732766	1		Toothed belt 25AT5
180	526311	1	+	Carriage easyLINE complete
180	526609	1	+	Long carriage easyLINE complete
190	526289	1		Stopper easyLINE complete

+ depending on design

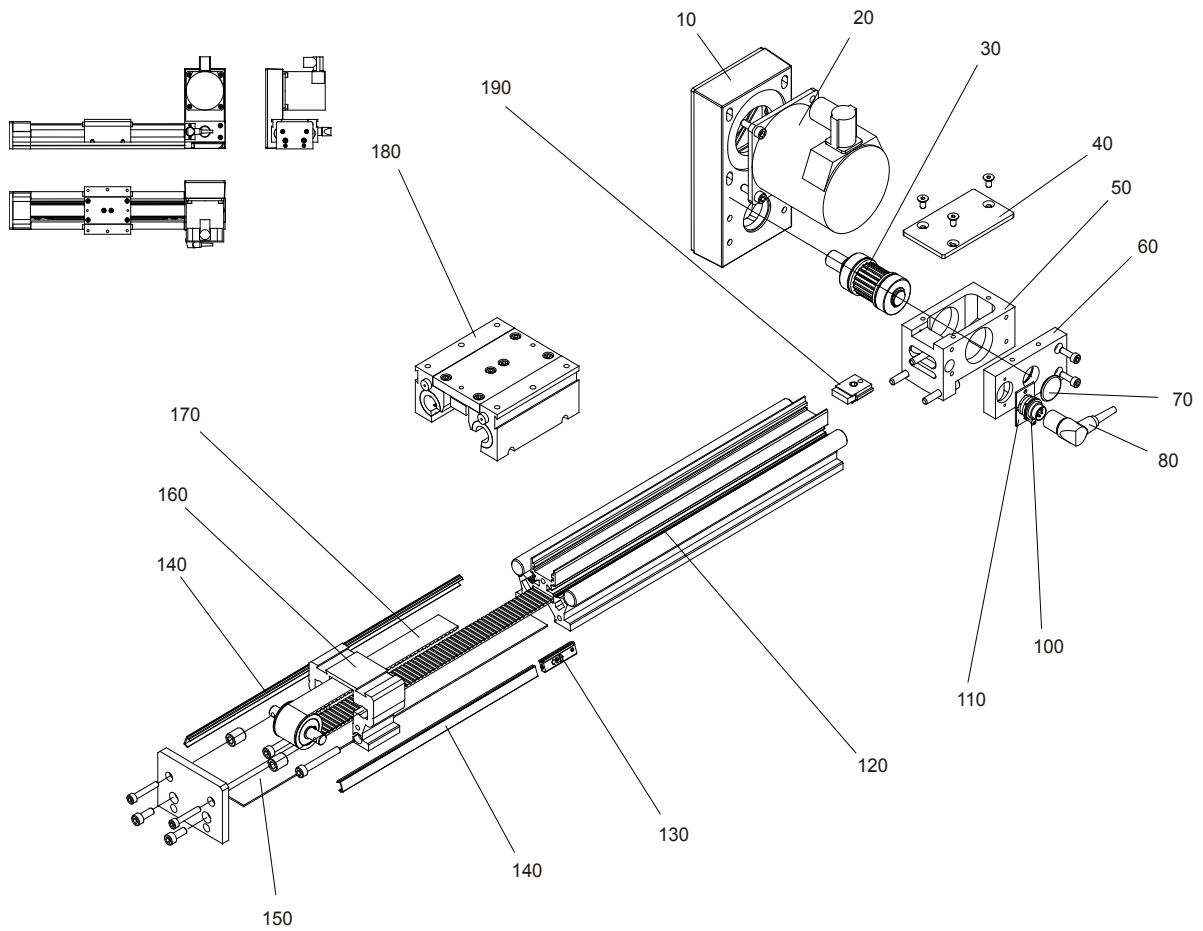

Figure 20: easyLINE exploded view

7.2 Reversing unit easyLINE (Article.No. 526261)

Drawing Pos.	Article no.	Part (1) / subassembly (0)	Usage	Designation
10	030313	1		Cover plate easyLINE
20	028580	1		Housing reversing unit easyLINE
30	527282	1		Pulley easyLINE
40	027736	1		Spacer sleeves (for limitation and controlling the tension of the toothed belt)
50	028576	1		Endplate easyLINE

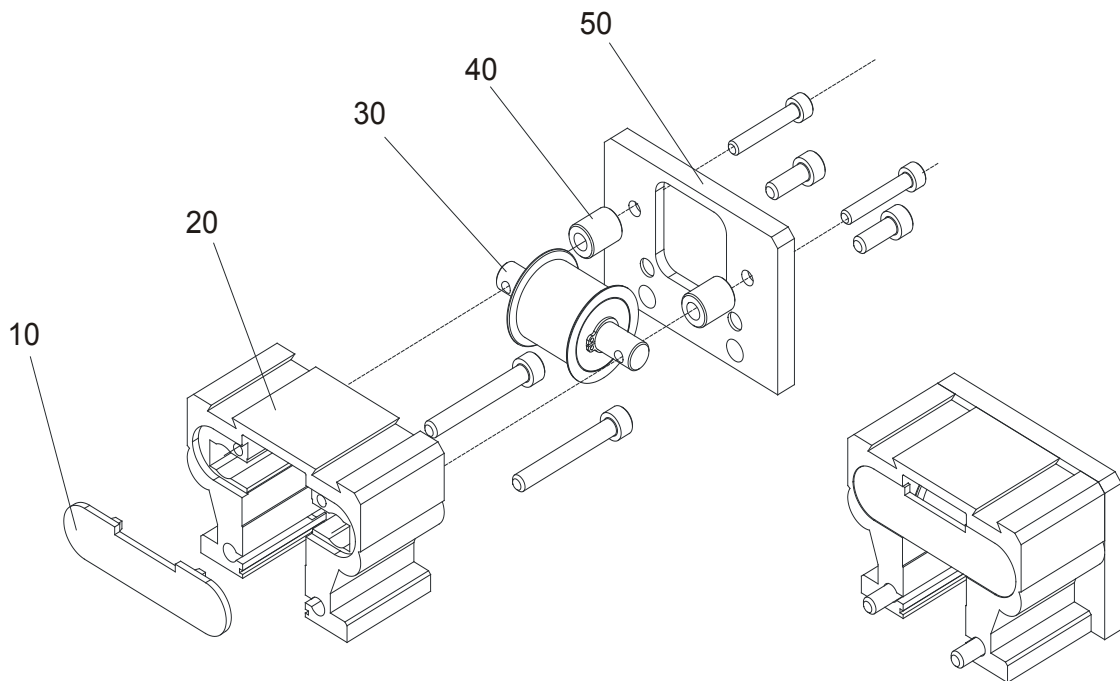

Figure 21: easyLINE, reversing unit exploded view

7.3 Carriage easyLINE completed (Article no. 526311)

Drawing Pos.	Article no.	Part (1) / subassembly (0)	Usage	Designation	
10	028581	1		Belt receptacle easyLINE	
20	028577	1		Carriage plate easyLINE	
30	526262	1		Clamping block easyLINE complete	
10	026481	1		Bumper green	
20	028584	1		Clamping block easyLINE	See clamping block complete exploded view <i>Chapter 7.7, page 31</i>
30	626046	1		Linear bearing	
40	1000492	1		Fixing screw	
40	626059	1		Cylinder head screw DIN 912-M5x16-8.8	
50	626488	1		Cylinder head screw DIN 912-M5x12-8.8	

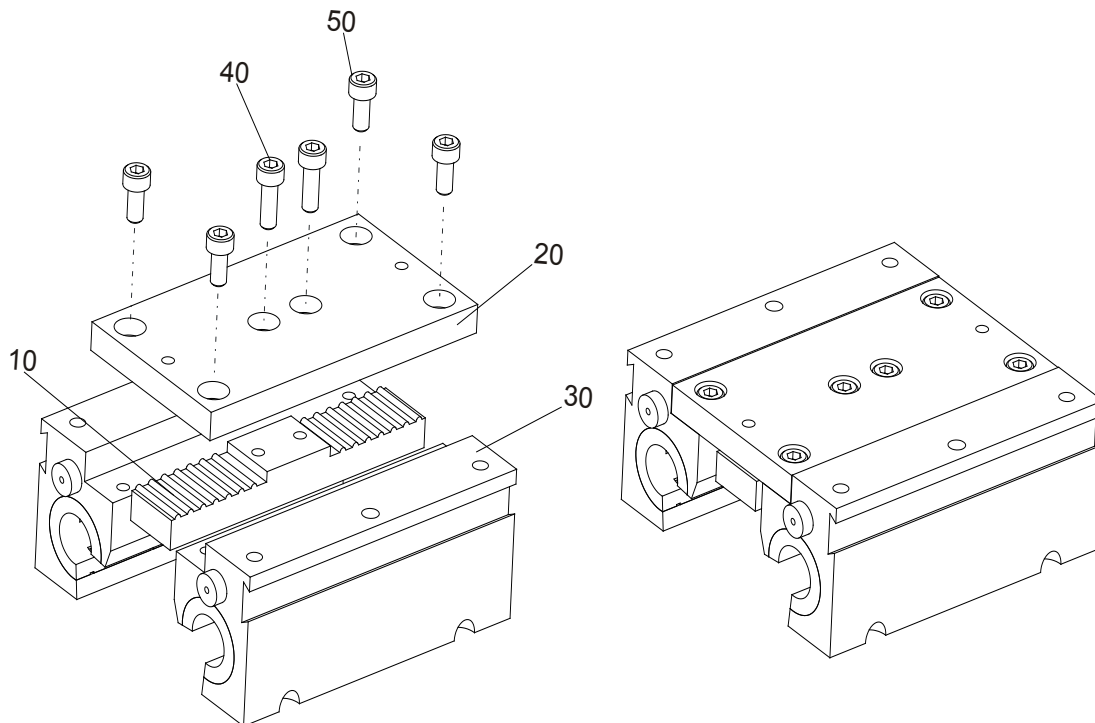

Figure 22: easyLINE, carriage complete

7.4 Long carriage easyLINE complete (Article no. 526609)

Drawing Pos.	Article no.	Part (1) / subassembly (0)	Usage	Designation
10	028581	1		Belt receptacle easyLINE
20	028919	1		Long slide plate easyLINE
30	526610	1		Long slide clamping block easyLINE cpl. (see chapter 7.8, page 32)
10	026481	1		Bumper green
20	028918	1		Double clamping block easyLINE
30	626046	1		Linear bearing
40	1000492	1		Fixing screw
40	626059	1		Cylinder head screw DIN 912-M5x16-8.8
50	626488	1		Cylinder head screw DIN 912-M5x12-8.8

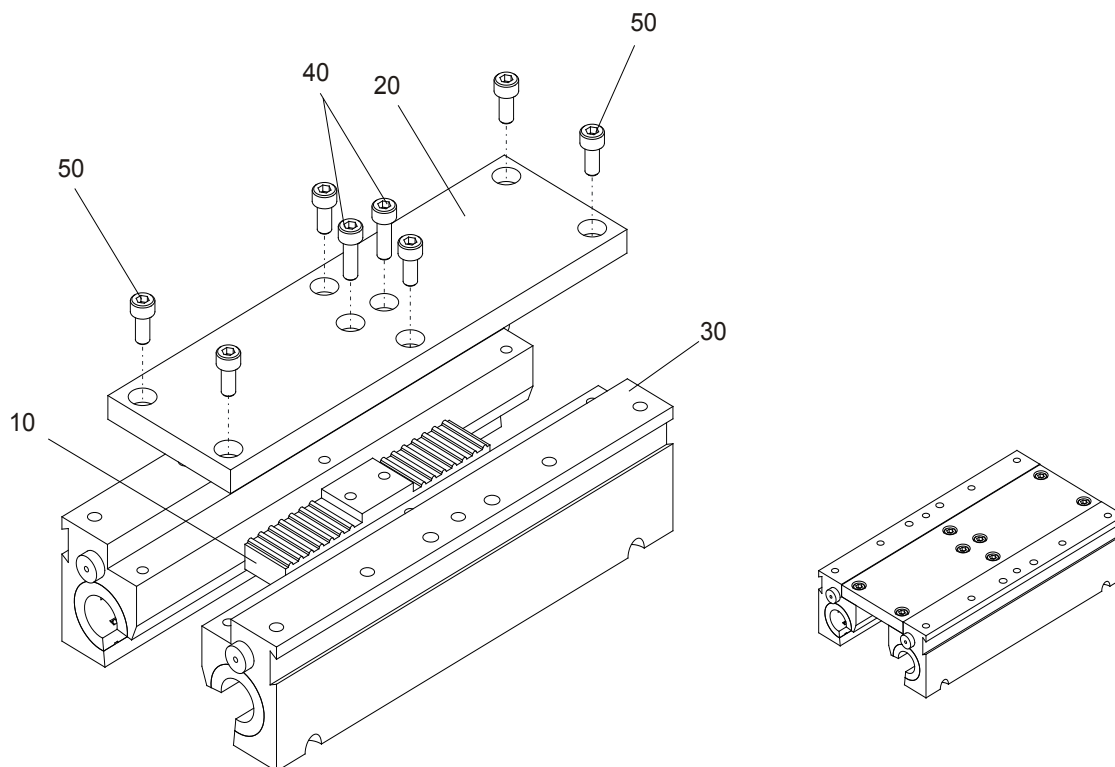

Figure 23: easyLINE, long carriage complete

7.5 Gearbox (Subassembly no. 1000002)

Drawing Pos.	Article. no.	Part (1) / subassembly (0)	Usage	Designation
10		1	+	Toothed belt
20	526628	1		Housing of the gearbox
30		1	+	Driven washer
40	527263	1		Clamping set 15/28
50		1	+	Washer for motor

+use depending on design

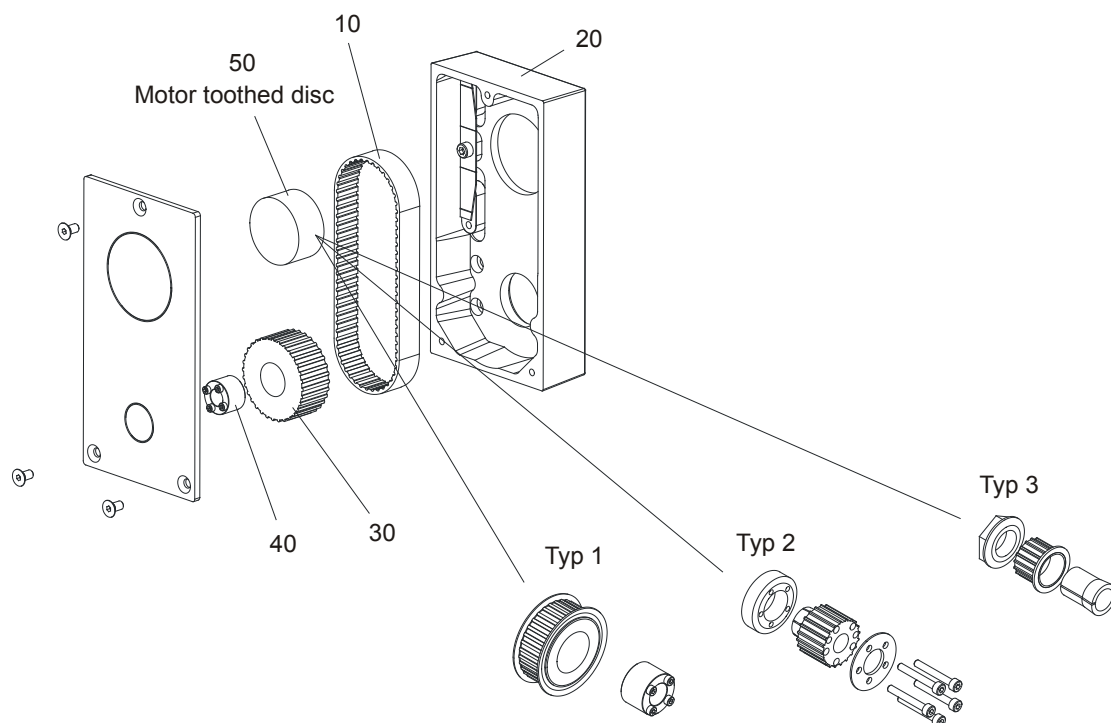

Figure 24: easyLINE, gearbox exploded view

7.6 Flange i = 1:1 (Subassembly no. 1000003)

Parts group no. 1000003

Drawing Pos.	Article no.	Part (1)/ subassembly (0)	Usage	Designation
10	028680	1		Motor flange i=1:1
20	1064076	1		Coupling d=15mm
30	1064079	1		Elastomere rim 98sh red
40		1	+	Coupling (motorside)

+use depending on design

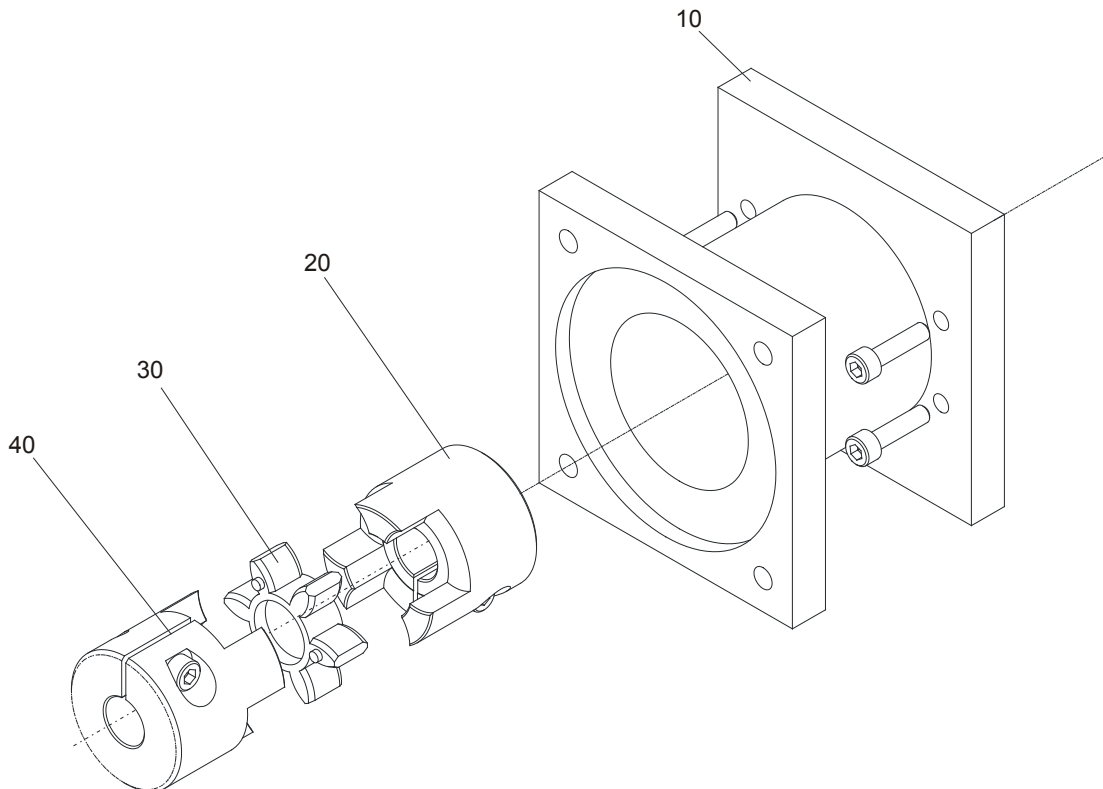

Figure 25:easyLINE Flange i=1:1



CAUTION

Please additionally observe the wear parts lists included with the delivery according to the order

7.7 easyLINE clamping block complete – exploded view (Article no. 526262)

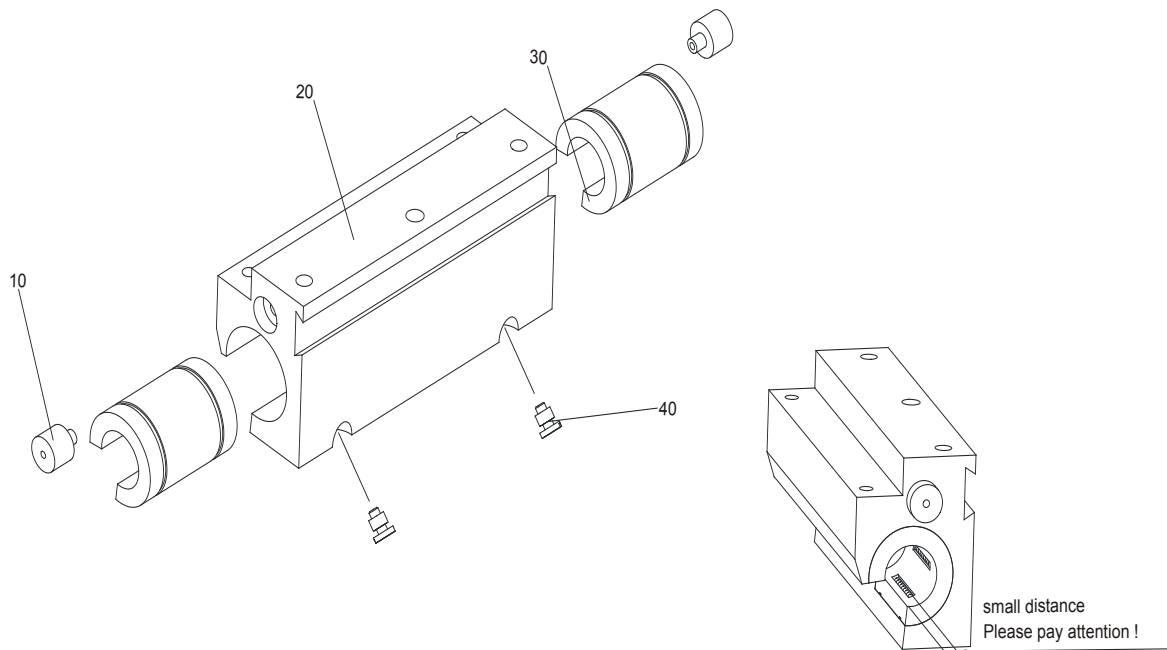

Figure 26: easyLINE clamping block complete

**7.8 easyLINE long carriage clamping block complete – exploded view
(Article no. 526610)**

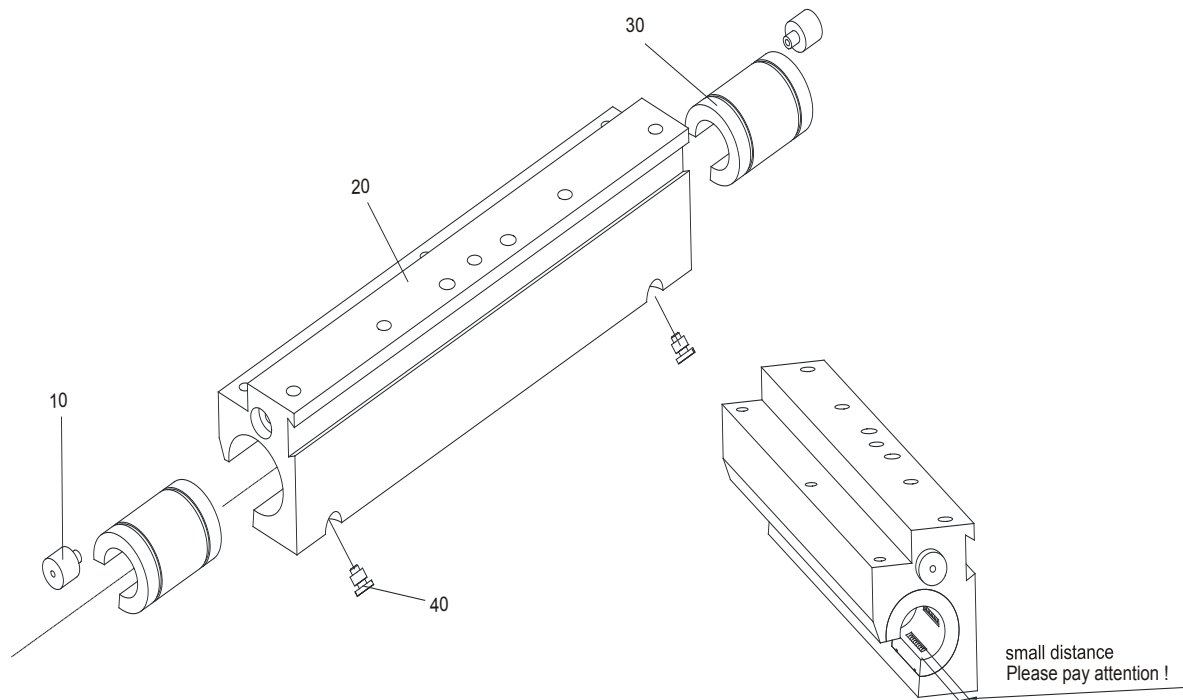

Figure 27: easyLINE long slide clamping block complete

7.9 easyLINE, parallel drive – exploded view

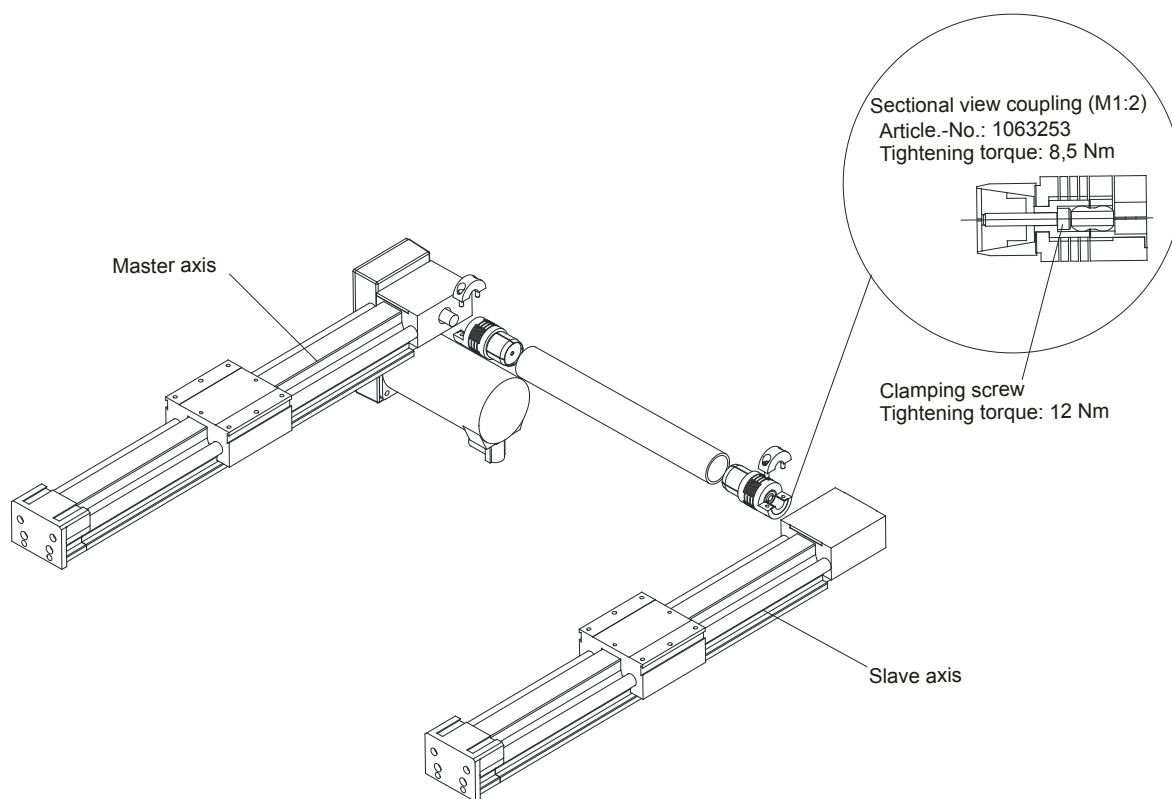

Figure 28: easyLINE parallel drive

8 Declaration of incorporation

EC declaration of incorporation in the sense of the EC directive 2006/42/EC (machinery), Annex II B

The manufacturer:

IEF-Werner GmbH

Wendelhofstraße 6

78120 Furtwangen - Germany

hereby declares that the following products (the incomplete machine/partial machine):

Designation	IEF-Werner subassembly number
easyLINE	TG1000010

where possible based on the scope of delivery, correspond to the following basic requirements of the directive on **Machinery (2006/42/EC)**:

- Annex I, item: 1.1.2; 1.1.3; 1.1.5; 1.3.2; 1.3.4; 1.5.1; 1.7.3.

The incomplete machine also corresponds to the following further directives:

- Directive **2014/30/EU** of the European Parliament and of the Council of 26 February 2014 on the harmonisation of the laws of the Member States relating to electromagnetic compatibility
- Directive **2014/35/EU** of the European Parliament and of the Council of 26 February 2014 on the harmonisation of the laws of the Member States relating to the making available on the market of electrical equipment designed for use within certain voltage limits

The technical documents were generated according to Annex VII part B and may be electronically submitted to the national authorities upon justified request.

List of some applied harmonised standards:

- EN ISO 12100:2010 / EN ISO 13850:2015 / EN ISO 13857:2008 / EN 60204-1:2006

Commissioning of the incomplete machine delivered by us is not permitted until it has been determined that the overall system into which the incomplete machine is installed meets the basic safety and health protection requirements according to Annex I of the above EC directive 2006/42/EC.

Name of the documentation officer: Frank Reichelt, technical editor

Address of the documentation officer: see manufacturer's address

Furtwangen, October 17, 2019



Stefan Deck (manager)